



**Bashkia Shkodër**

## PROJEKT ZBATIMI

### **Rikonstruktion Rruga "Memej"**

- 01- Hoorografia
- 02- Topografia e rruges
- 03- Planimetria e rruges
- 04- Profili Gjatesore
- 05- Profilat Terthore
- 06- Profili Terthore Tip
- 07- KUZ
- 08- KUSH
- 09- Sinjalistika
- 10- Ujesjellesi
- 11- Ndriçimi Rrugor

MIRATOHET  
KRYETARI I BASHKISË  
Z. BARDH SPAHIA

PROJEKTOI:  
"LENI-ING" SH.P.K  
&  
"ANGERBA" SH.P.K

TIRANË 2023



FILLIMI I  
RRUGES

MBARIMI I  
RRUGES

Porositi :



**Bashkia Shkodër**

Projektoi:

**"LENI-ING" sh.p.k  
&  
"ANGERBA" sh.p.k**

Adresa: Rr. Uran Pano, Pallati 12 kat, Kati 2  
Mobile: 0682042270  
Email: leni-ing@hotmail.com

Objekti: <b>Rikonstrukcion Rruga "Memej"</b>		
Faza: <b>Projekt - Zbatim</b>		
Emërtimi i Fletës: <b>HOOROGRAFIA</b>	Shkalla: Sh 1:1000	Tiranë 2023 <b>HORO</b>



**Bashkia Shkodër**

## PROJEKT ZBATIMI

### **Rikonstruktion Rruga "Memej"**

- 01- Hoorografia
- 02- Topografia e rruges
- 03- Planimetria e rruges
- 04- Profili Gjatesore
- 05- Profilat Terthore
- 06- Profili Terthore Tip
- 07- KUZ
- 08- KUSH
- 09- Sinjalistika
- 10- Ujesjellesi
- 11- Ndriçimi Rrugor

MIRATOHET  
KRYETARI I BASHKISË  
Z. BARDH SPAHIA

PROJEKTOI:  
"LENI-ING" SH.P.K  
&  
"ANGERBA" SH.P.K

TIRANË 2023

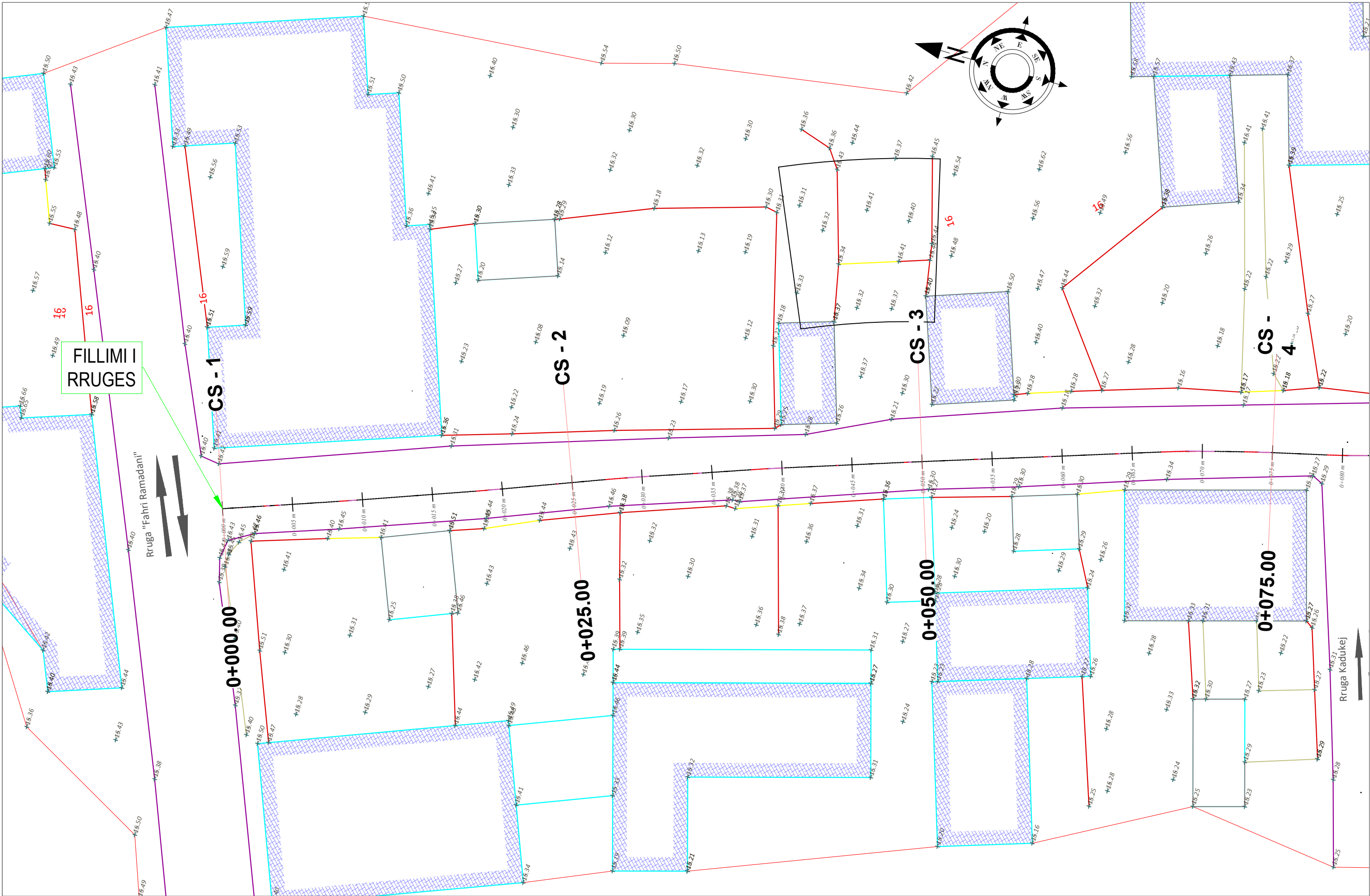

**FILLIMI I RRUGES**

**Rruga "Fahri Ramadani"**

**Rruga Kadukej**

- SHPJEGUES**
- 156.95 Pike detaje
  - 158.00 Izohipse
  - Objekt
  - Kanal Natyral
  - Rrethim
  - Mur Rrethues

Porositi :



**Bashkia Shkodër**

Projektoi:

**"LENI-ING" sh.p.k**  
**&**  
**"ANGERBA" sh.p.k**

Adresa: Rr. Uran Pano, Pallati 12 kat, Kati 2  
 Mobile: 0682042270  
 Email: leni-ing@hotmail.com

Objekti: <b>Rikonstrukcion Rruga "Memej"</b>		
Faza: <b>Projekt - Zbatim</b>		
Emërtimi i Fletës:	Shkalla:	Tiranë 2023
<b>TOPOGRAFIA E RRUGES</b>	Sh 1:250	Topo

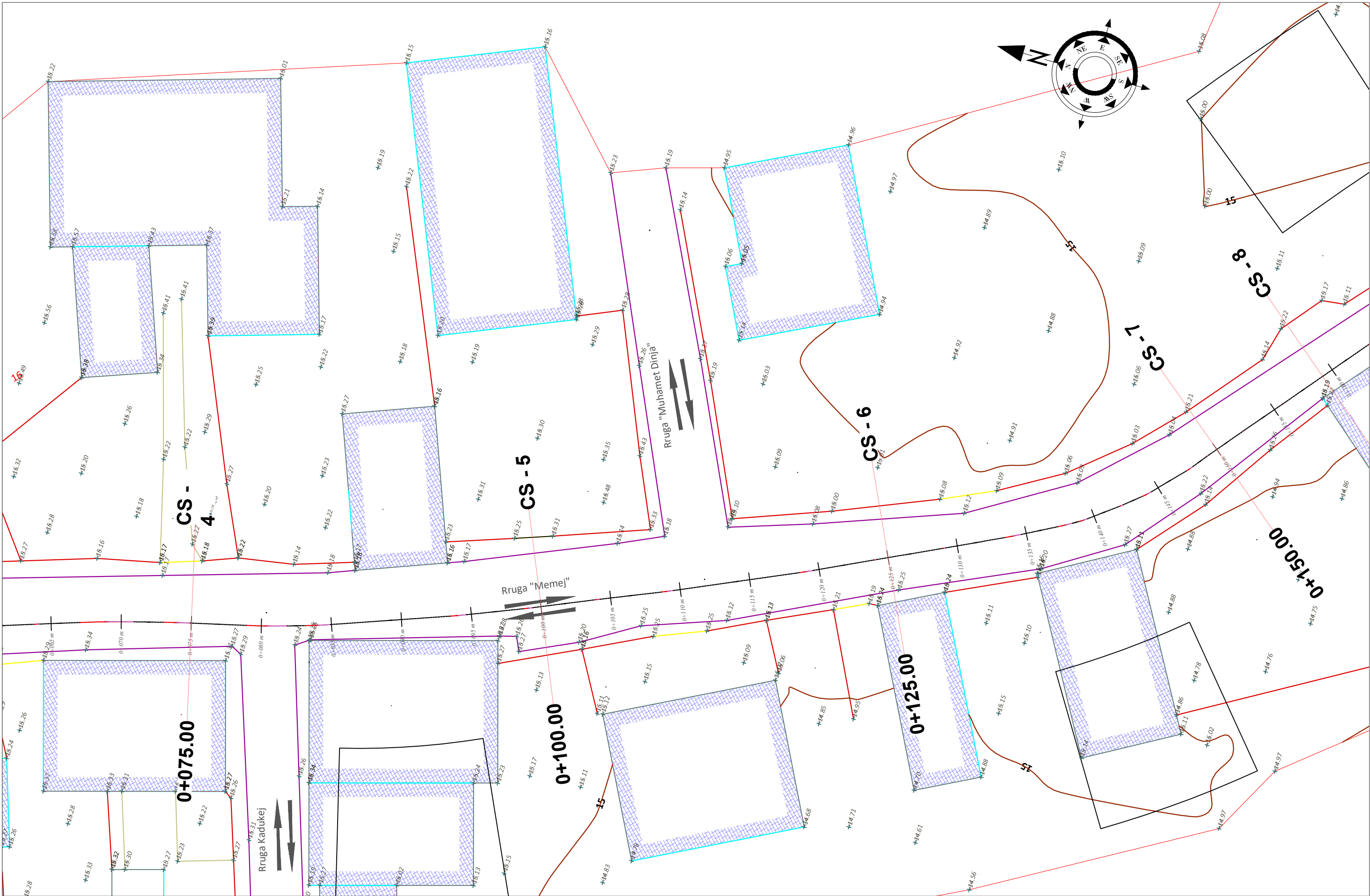

**SHPJEGUES**

- 156.95 Pike detaje
- 158.00 Izohipse
- Objekt
- Kanal Natyral
- Rrëhim
- Mur Rrëthues

Porositi :



Projektoi:

**"LENI-ING" sh.p.k**  
**&**  
**"ANGERBA" sh.p.k**

Adresa: Rr. Uran Pano, Pallati 12 kat, Kati 2  
 Mobile: 0682042270  
 Email: leni-ing@hotmail.com

Objekti: **Rikonstrukcion Rruga "Memej"**

Faza: **Projekt - Zbatim**

Emërtimi i Fletës:  
**TOPOGRAFIA**  
**E RRUGES**

Shkalla:  
 Sh 1:250

Tiranë 2023  
 Topo  
 (2)

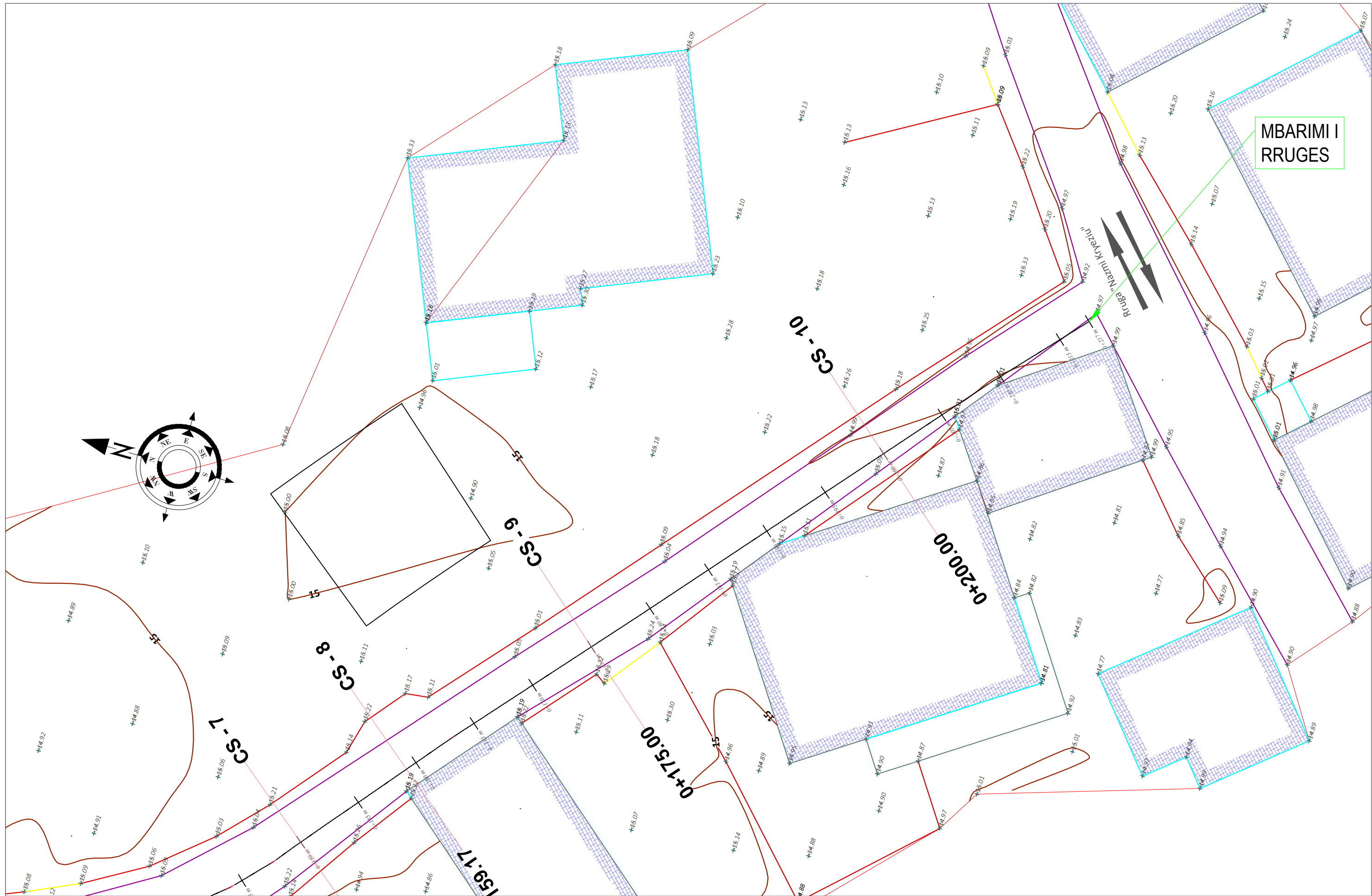

Porositi :



**Bashkia Shkodër**

Projektoi:

**"LENI-ING" sh.p.k**  
**&**  
**"ANGERBA" sh.p.k**

Adresa: Rr. Uran Pano, Pallati 12 kat, Kati 2  
 Mobile: 0682042270  
 Email: leni-ing@hotmail.com

Objekti: <b>Rikonstrukcion Rruga "Memej"</b>		
Faza: <b>Projekt - Zbatim</b>		
Emërtimi i Fletës:	Shkalla:	Tiranë 2023
<b>TOPOGRAFIA E RRUGES</b>	Sh 1:250	Topo (3)



**Bashkia Shkodër**

## PROJEKT ZBATIMI

### **Rikonstruktion Rruga "Memej"**

- 01- Hoorografia
- 02- Topografia e rruges
- 03- Planimetria e rruges
- 04- Profili Gjatesore
- 05- Profilat Terthore
- 06- Profili Terthore Tip
- 07- KUZ
- 08- KUSH
- 09- Sinjalistika
- 10- Ujesjellesi
- 11- Ndriçimi Rrugor

MIRATOHET  
KRYETARI I BASHKISË  
Z. BARDH SPAHIA

PROJEKTOI:  
"LENI-ING" SH.P.K  
&  
"ANGERBA" SH.P.K

TIRANË 2023

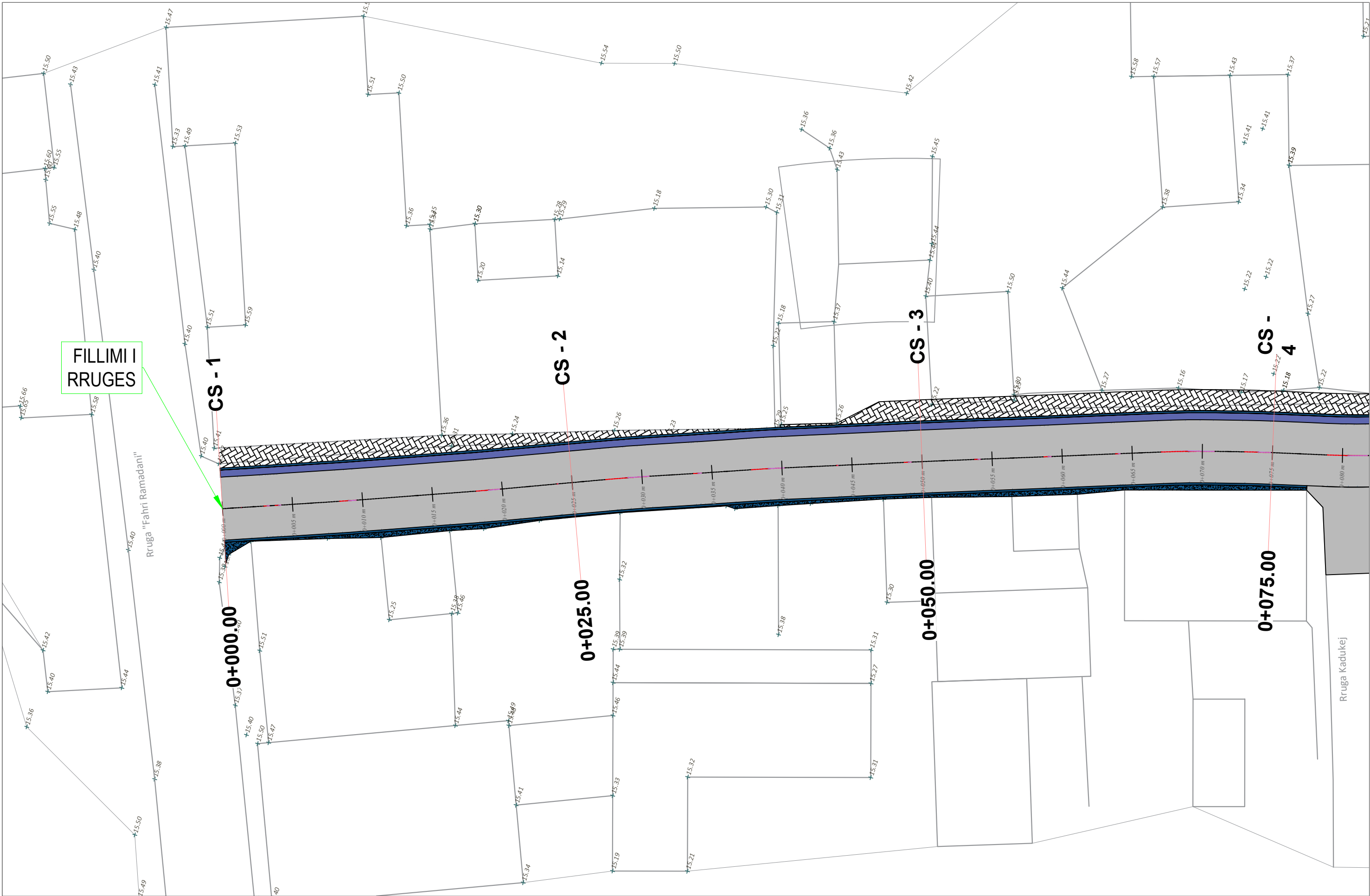

**SHPJEGUES**

- 156.95 Pike detaje
- 158.0 Izohipse
- Objekt
- Kanal Natyral
- Rrethim
- Mur Rrethues

Porositi :



**Bashkia Shkodër**

Projektoi:

**"LENI-ING" sh.p.k**  
**&**  
**"ANGERBA" sh.p.k**

Adresa: Rr. Uran Pano, Pallati 12 kat, Kati 2  
 Mobile: 0682042270  
 Email: leni-ing@hotmail.com

Objekti: <b>Rikonstrukcion Rruga "Memej"</b>		
Faza: <b>Projekt - Zbatim</b>		
Emërtimi i Fletës:	Shkalla:	Tiranë 2023
<b>PLANIMETRIA E RRUGES</b>	Sh 1:250	PL



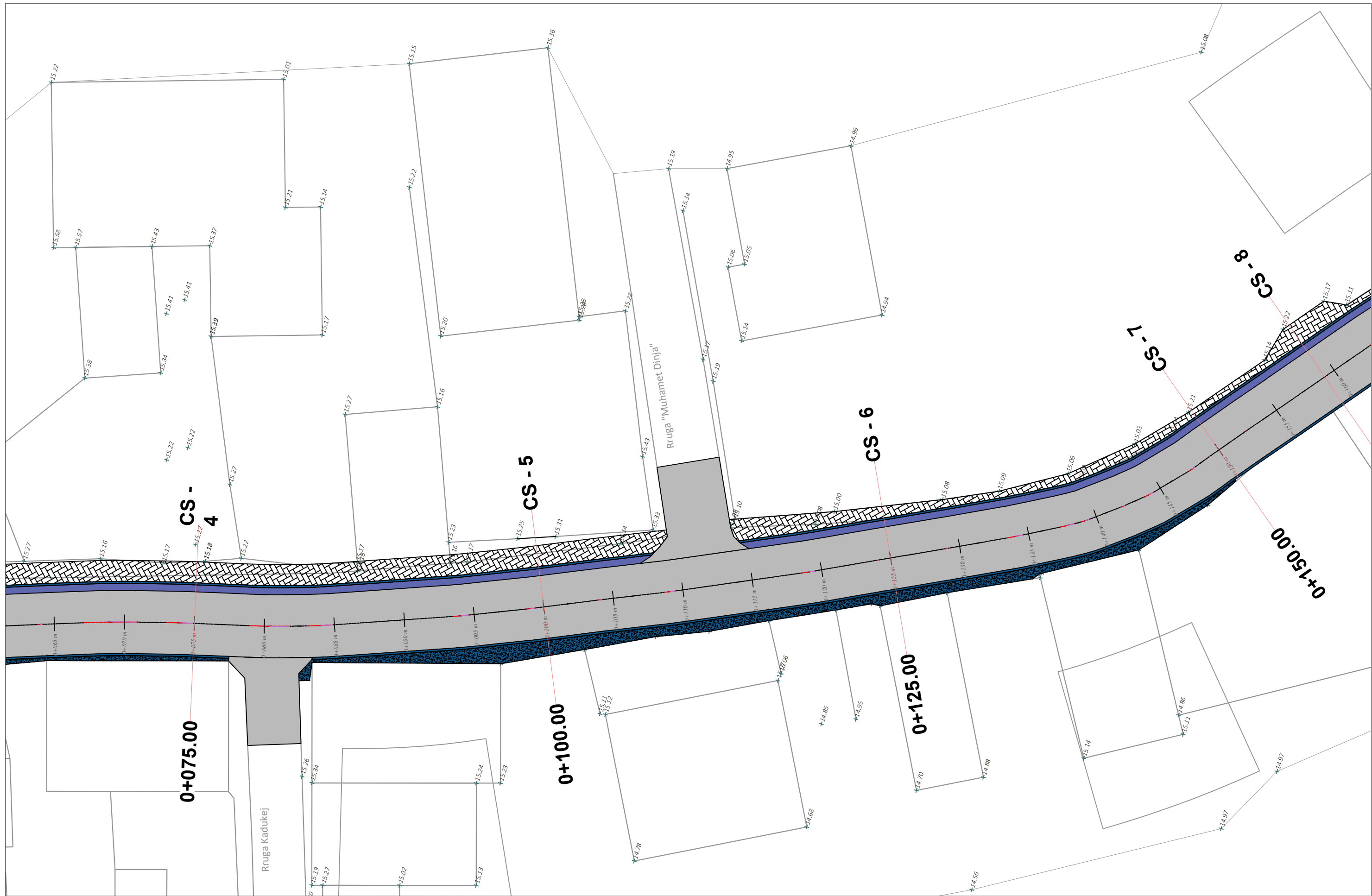

- SHPJEGUES**
- 156.95 Pike detaje
  - 158.0 Izohipse
  - Objekt
  - Kanal Natyral
  - Rrethim
  - Mur Rrethues

Porositi :



**Bashkia Shkodër**

Projektoi:

**"LENI-ING" sh.p.k**  
**&**  
**"ANGERBA" sh.p.k**

Adresa: Rr. Uran Pano, Pallati 12 kat, Kati 2  
 Mobile: 0682042270  
 Email: leni-ing@hotmail.com

Objekti: <b>Rikonstrukcion Rruga "Memej"</b>		
Faza: <b>Projekt - Zbatim</b>		
Emërtimi i Fletës: <b>PLANIMETRIA E RRUGES</b>	Shkalla: Sh 1:250	Tiranë 2023 PL (2)



MBARIMI I  
RRUGES

**SHPJEGUES**

	Pike detaje
	Izohipse
	Objekt
	Kanal Natyral
	Rrethim
	Mur Rrethues

Porositi :



**Bashkia Shkodër**

Projektoi:

**"LENI-ING" sh.p.k**  
&  
**"ANGERBA" sh.p.k**

Adresa: Rr. Uran Pano, Pallati 12 kat, Kati 2  
Mobile: 0682042270  
Email: leni-ing@hotmail.com

Objekti: <b>Rikonstrukcion Rruga "Memej"</b>		
Faza: <b>Projekt - Zbatim</b>		
Emërtimi i Fletës:	Shkalla:	Tiranë 2023
<b>PLANIMETRIA E RRUGES</b>	Sh 1:250	PL (3)



**Bashkia Shkodër**

## PROJEKT ZBATIMI

### **Rikonstruktion Rruga "Memej"**

- 01- Hoorografia
- 02- Topografia e rruges
- 03- Planimetria e rruges
- 04- Profili Gjatesore
- 05- Profilat Terthore
- 06- Profili Terthore Tip
- 07- KUZ
- 08- KUSH
- 09- Sinjalistika
- 10- Ujesjellesi
- 11- Ndriçimi Rrugor

MIRATOHET  
KRYETARI I BASHKISË  
Z. BARDH SPAHIA

PROJEKTOI:  
"LENI-ING" SH.P.K  
&  
"ANGERBA" SH.P.K

TIRANË 2023





**Bashkia Shkodër**

## PROJEKT ZBATIMI

### **Rikonstruktion Rruga "Memej"**

- 01- Hoorografia
- 02- Topografia e rruges
- 03- Planimetria e rruges
- 04- Profili Gjatesore
- 05- Profilat Terthore
- 06- Profili Terthore Tip
- 07- KUZ
- 08- KUSH
- 09- Sinjalistika
- 10- Ujesjellesi
- 11- Ndriçimi Rrugor

MIRATOHET  
KRYETARI I BASHKISË  
Z. BARDH SPAHIA

PROJEKTOI:  
"LENI-ING" SH.P.K  
&  
"ANGERBA" SH.P.K

TIRANË 2023





TABELA VOLUMEVE							
PROGRESIVA	SIP. GERMIM	SIP. MBUSHJE	VOL. GERMIM	VOL. MBUSHJE	G. PROGRESIV	M. PROGRESIV	G-M
0+00.00	4.13	0.00	0.00	0.00	0.00	0.00	<b>0.00</b>
0+25.00	3.35	0.00	93.46	0.00	93.46	0.00	<b>93.46</b>
0+50.00	3.22	0.00	82.31	0.00	175.77	0.00	<b>175.77</b>
0+75.00	3.48	0.00	84.00	0.00	259.77	0.00	<b>259.77</b>
1+00.00	3.96	0.00	92.50	0.00	352.27	0.00	<b>352.27</b>
1+25.00	3.70	0.00	95.64	0.00	447.90	0.00	<b>447.90</b>
1+50.00	3.51	0.00	89.46	0.00	537.36	0.00	<b>537.36</b>
1+59.17	3.49	0.00	32.13	0.00	569.49	0.00	<b>569.49</b>
1+75.00	3.84	0.00	58.12	0.00	627.61	0.00	<b>627.61</b>
2+00.00	3.44	0.00	91.00	0.00	718.61	0.00	<b>718.61</b>

Porositi :

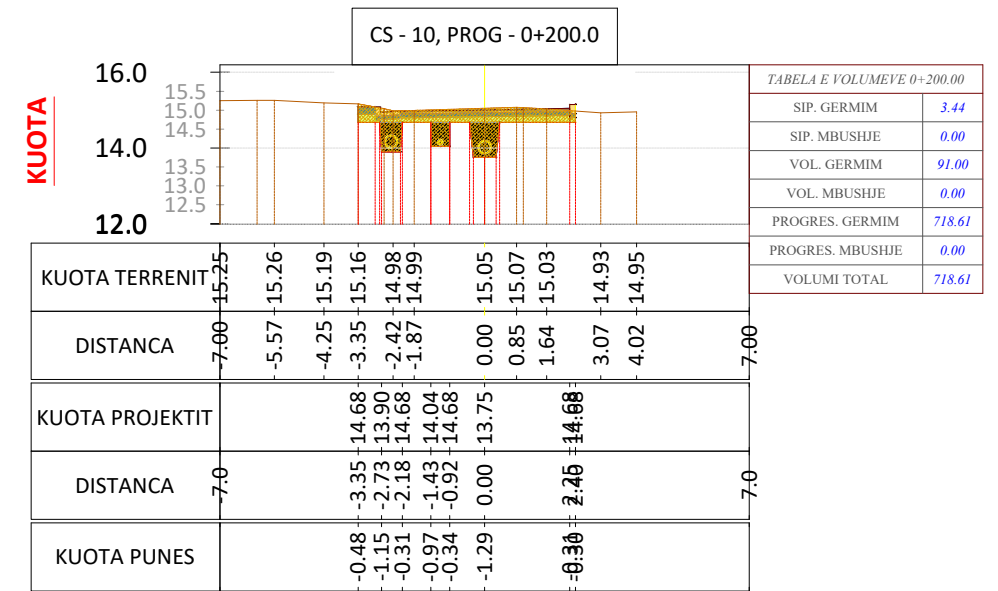
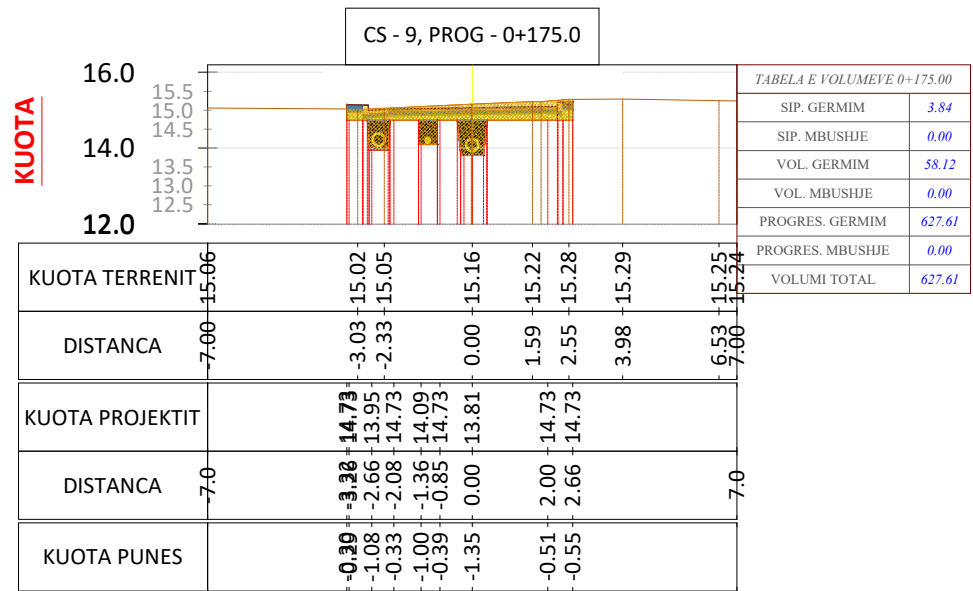
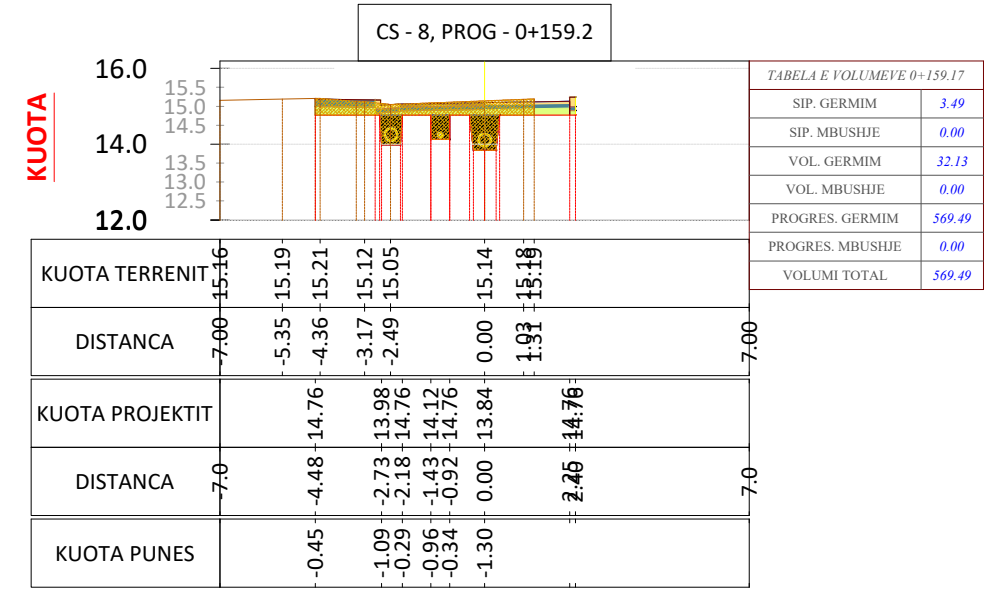
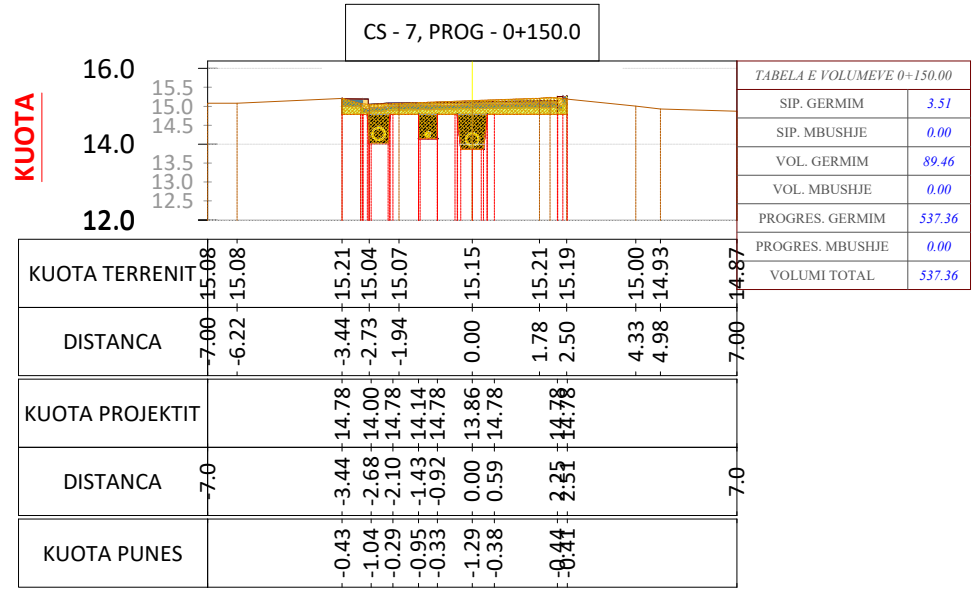

Projektoi:

**"LENI-ING" sh.p.k**  
**&**  
**"ANGERBA" sh.p.k**

Adresa: Rr. Uran Pano, Pallati 12 kat, Kati 2  
 Mobile: 0682042270  
 Email: leni-ing@hotmail.com

Objekti: **Rikonstruksion Rruga "Memej"**

Faza: **Projekt - Zbatim**

Emërtimi i Fletës:  
**TABELAT E**  
**VOLUMEVE**

Shkalla:  
 Sh 1:200

Tiranë 2023

TB





**Bashkia Shkodër**

## PROJEKT ZBATIMI

### **Rikonstruktion Rruga "Memej"**

- 01- Hoorografia
- 02- Topografia e rruges
- 03- Planimetria e rruges
- 04- Profili Gjatesore
- 05- Profilat Terthore
- 06- Profili Terthore Tip
- 07- KUZ
- 08- KUSH
- 09- Sinjalistika
- 10- Ujesjellesi
- 11- Ndriçimi Rrugor

MIRATOHET  
KRYETARI I BASHKISË  
Z. BARDH SPAHIA

PROJEKTOI:  
"LENI-ING" SH.P.K  
&  
"ANGERBA" SH.P.K

TIRANË 2023

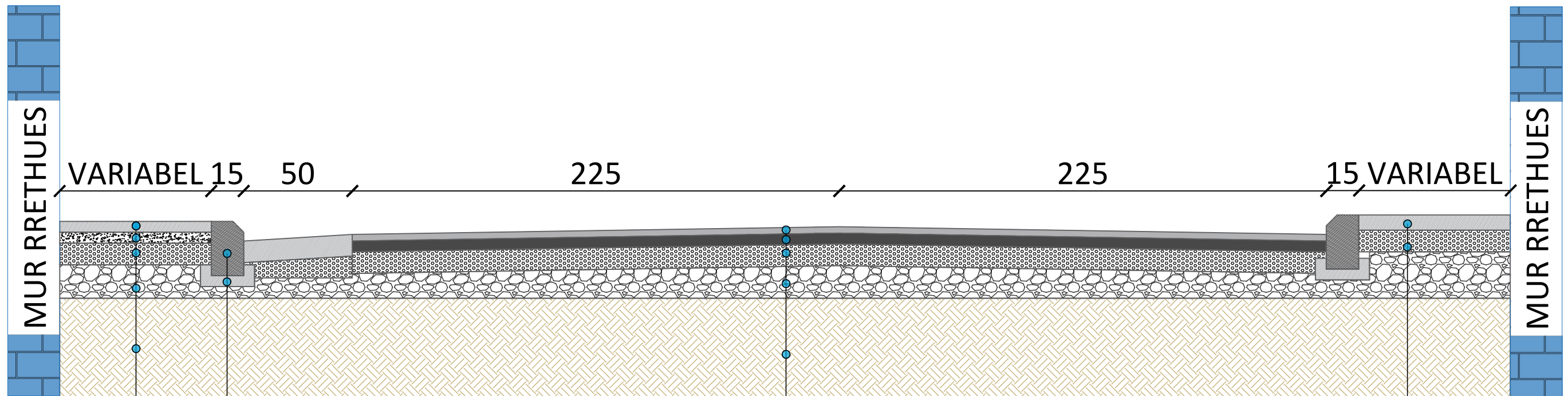

Trotuar me Pllaka Granili  
 Rere t=5 cm  
 Shtrese Zhavorri t=10 cm  
 Çakull t=20 cm  
 Toke natyrale

Bordure 15x25 cm  
 Beton per fiksimin e bordures

Asfaltobeton t=3 cm  
 Binder t=5 cm  
 Stabilizant t=10 cm  
 Çakull t=20 cm  
 Toke natyrale

Beton i Derdhur t=7 cm  
 Çakull t=20 cm

Porositi :	Projektoi:	Objekti: <b>Rikonstruksion Rruga "Selim Gjyrezi"</b>	
 <b>Bashkia Shkodër</b>	<b>"LENI-ING" sh.p.k</b> <b>&amp;</b> <b>"ANGERBA" sh.p.k</b> <small>Adresa: Rr. Uran Pano, Pallati 12 kat, Kati 2          Mobile: 0682042270          Email: leni-ing@hotmail.com</small>	Faza:	Projekt - Zbatim
		Emërtimi i Fletës:	Shkalla:
		PROFILI TERTHORE TIP	Sh 1:20 PT

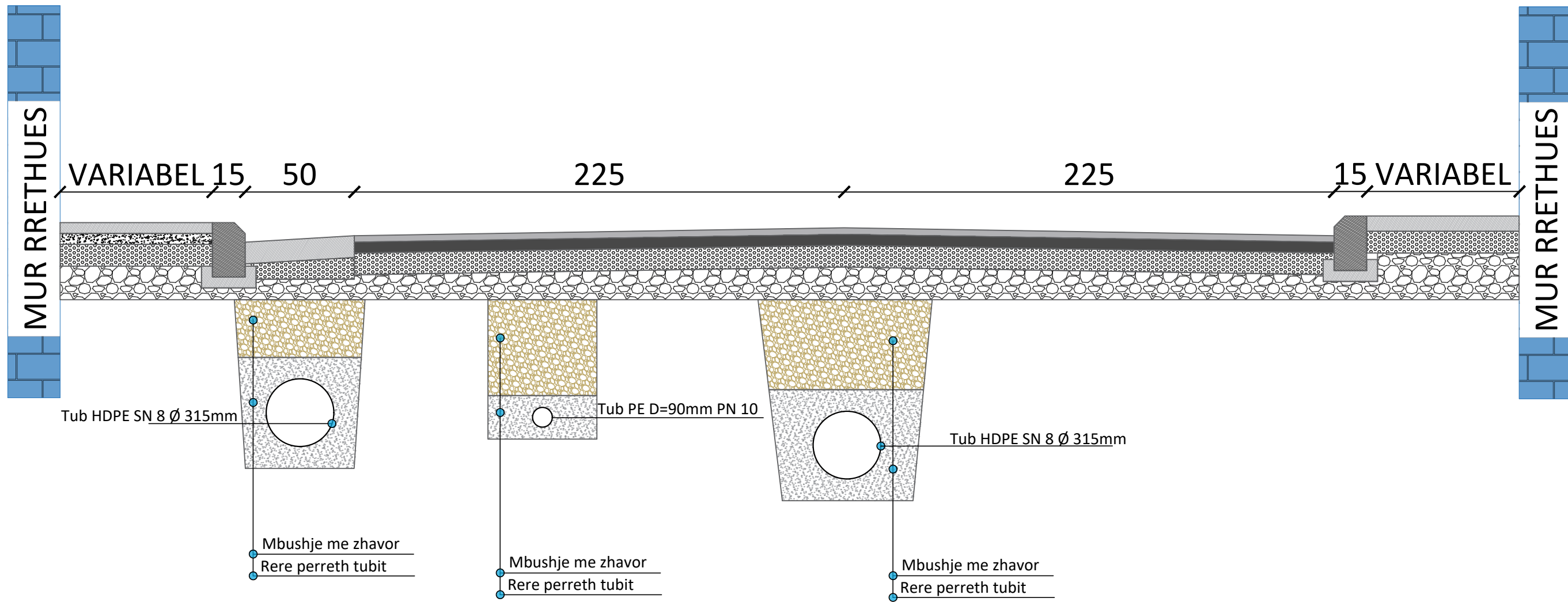

Porositi :



**Bashkia Shkodër**

Projektoi:

**"LENI-ING" sh.p.k**  
&  
**"ANGERBA" sh.p.k**

Adresa: Rr. Uran Pano, Pallati 12 kat, Kati 2  
Mobile: 0682042270  
Email: leni-ing@hotmail.com

Objekti: <b>Rikonstruksion Rruga "Selim Gjyzezi"</b>		
Faza: <b>Projekt - Zbatim</b>		
Emërtimi i Fletës: <b>PROFILI TERTHORE TIP</b>	Shkalla: Sh 1:20	Tiranë 2023 PT (2)



**Bashkia Shkodër**

## PROJEKT ZBATIMI

### **Rikonstruktion Rruga "Memej"**

- 01- Hoorografia
- 02- Topografia e rruges
- 03- Planimetria e rruges
- 04- Profili Gjatesore
- 05- Profilat Terthore
- 06- Profili Terthore Tip
- 07- KUZ
- 08- KUSH
- 09- Sinjalistika
- 10- Ujesjellesi
- 11- Ndriçimi Rrugor

MIRATOHET  
KRYETARI I BASHKISË  
Z. BARDH SPAHIA

PROJEKTOI:  
"LENI-ING" SH.P.K  
&  
"ANGERBA" SH.P.K

TIRANË 2023

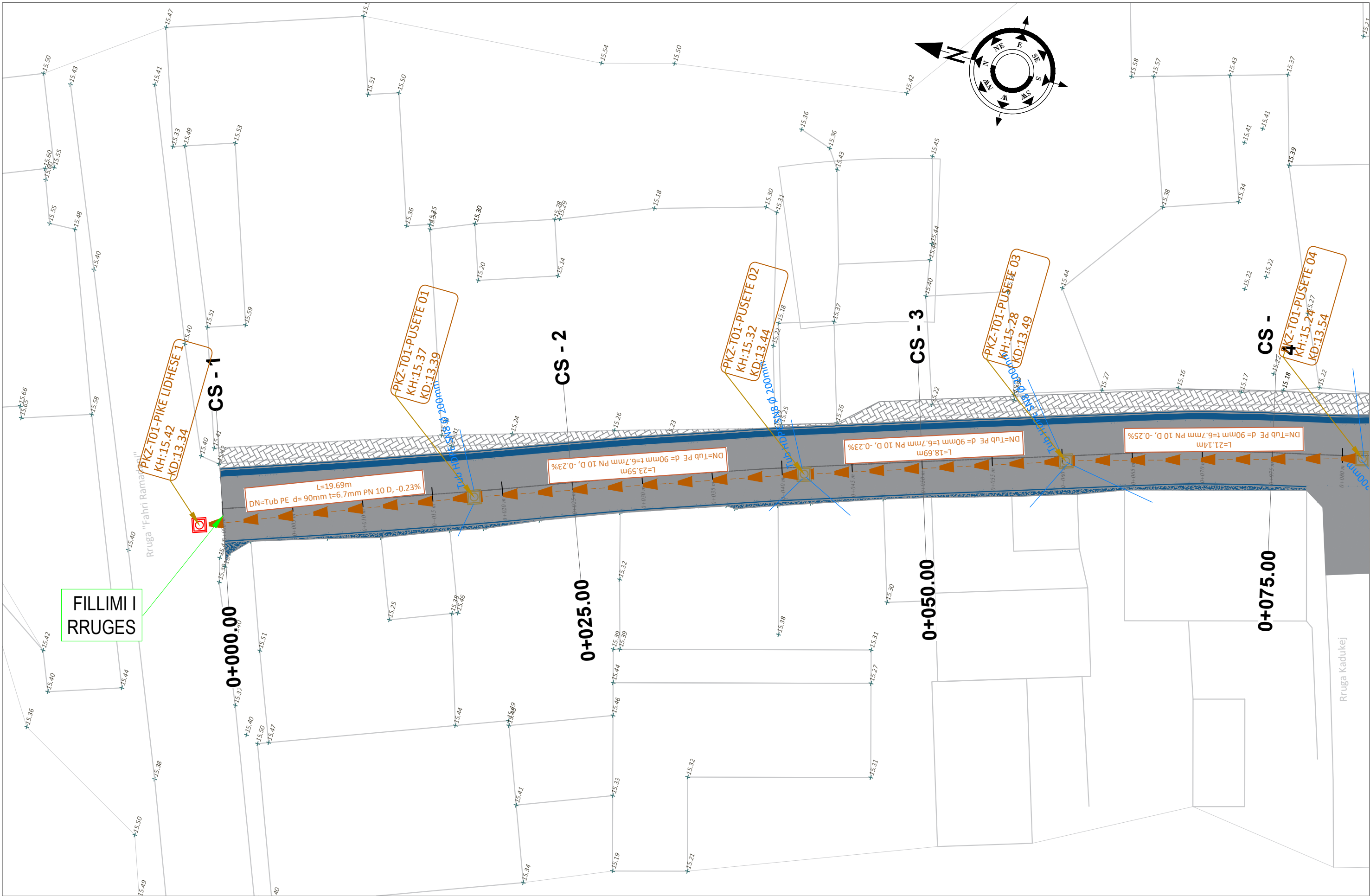

FILLIMI I RRUGES

- SHPJEGUES**
- 156.95 Pike detaje
  - 158.0 Izohipse
  - Objekt
  - Kanal Natyral
  - Rrethim
  - Mur Rrethues

Porositi :



**Bashkia Shkodër**

Projektoi:

**"LENI-ING" sh.p.k**  
**&**  
**"ANGERBA" sh.p.k**

Adresa: Rr. Uran Pano, Pallati 12 kat, Kati 2  
 Mobile: 0682042270  
 Email: leni-ing@hotmail.com

Objekti: <b>Rikonstrukcion Rruga "Memej"</b>		
Faza: <b>Projekt - Zbatim</b>		
Emërtimi i Fletës:	Shkalla:	Tiranë 2023
PLANIMETRIA E RRUGES KUZ	Sh 1:250	PL KUZ

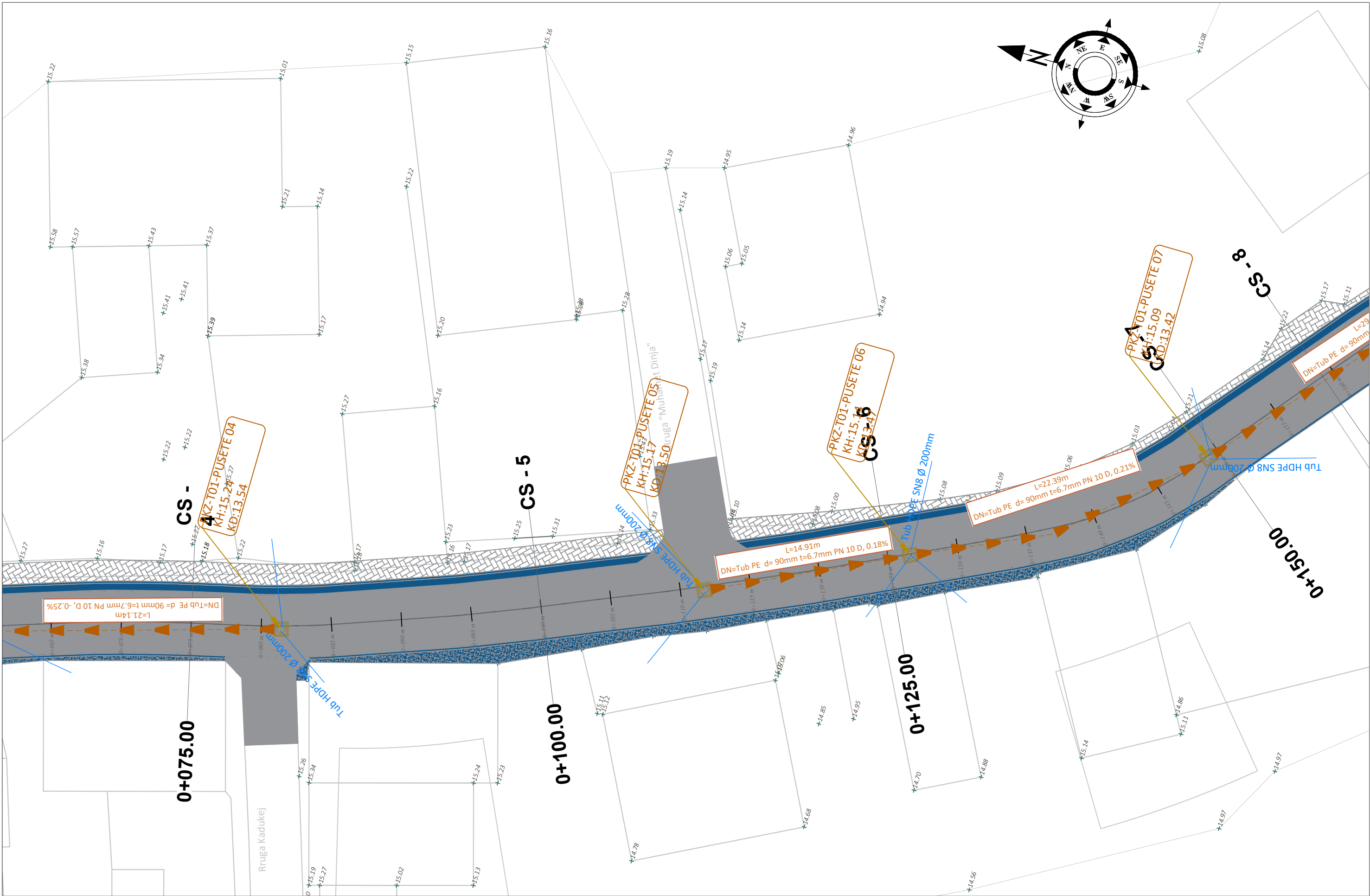
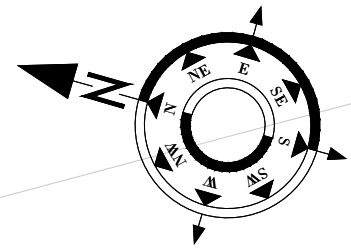

**SHPJEGUES**

- 156.95 Pike detaje
- 158.0 Izohipse
- Objekt
- Kanal Natyral
- Rrethim
- Mur Rrethues

Porositi :



**Bashkia Shkodër**

Projektoi:

**"LENI-ING" sh.p.k**  
**&**  
**"ANGERBA" sh.p.k**

Adresa: Rr. Uran Pano, Pallati 12 kat, Kati 2  
 Mobile: 0682042270  
 Email: leni-ing@hotmail.com

Objekti: <b>Rikonstrukcion Rruga "Memej"</b>		
Faza: <b>Projekt - Zbatim</b>		
Emërtimi i Fletës: <b>PLANIMETRIA E RRUGES KUZ</b>	Shkalla: <b>Sh 1:250</b>	Tiranë 2023 <b>PL KUZ (2)</b>

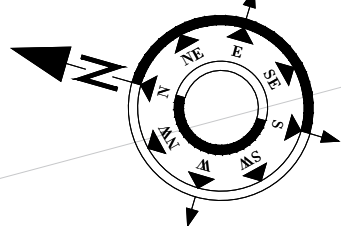

MBARIMI I RRUGES

Pika e lidhjes 2

**SHPJEGUES**

	Pike detaje
	Izohipse
	Objekt
	Kanal Natyral
	Rrethim
	Mur Rrethues

Porositi :



**Bashkia Shkodër**

Projektoi:

**"LENI-ING" sh.p.k**  
**&**  
**"ANGERBA" sh.p.k**

Adresa: Rr. Uran Pano, Pallati 12 kat, Kati 2  
 Mobile: 0682042270  
 Email: leni-ing@hotmail.com

Objekti: <b>Rikonstrukcion Rruga "Memej"</b>		
Faza: <b>Projekt - Zbatim</b>		
Emërtimi i Fletës: <b>PLANIMETRIA E RRUGES KUZ</b>	Shkalla: Sh 1:250	Tiranë 2023 PL KUZ (3)

PROFILI GJATESOR  
Aksi i Rruges Memej  
SH\_H - 1:1000  
SH\_V - 1:100

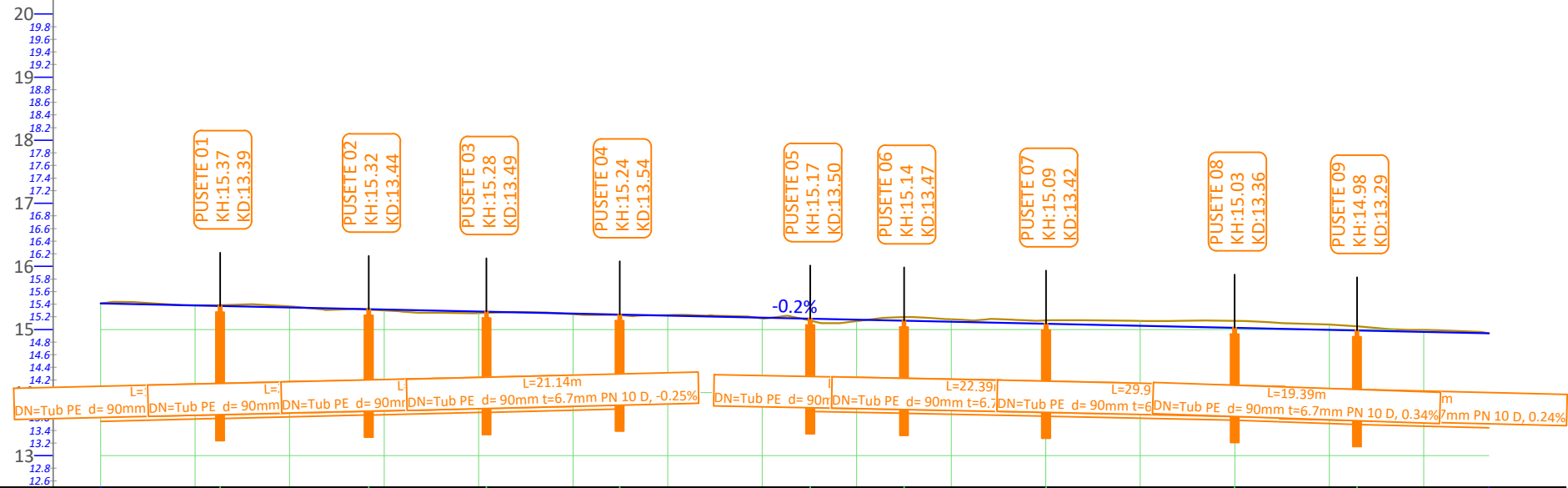

Gjatesia (Li)	L= 19.7m	L= 23.6m	L= 18.7m	L= 21.1m	L= 14.9m	L= 22.4m	L= 29.9m	L= 19.4m	L= 21.7m		
Nr.Pusetes	D=400mm	D=400mm	D=400mm	D=400mm	D=400mm	D=400mm	D=400mm	D=400mm	D=400mm	Pipe Lidhese-2	
Pjeresia (i%)	i=-0.23%	i=-0.23%	i=-0.23%	i=-0.25%	i=0.18%	i=0.21%	i=0.22%	i=0.34%	i=0.24%		
Kuote Tubi (Rrjedhes)	13.34m	13.39m 13.39m	13.44m 13.44m	13.49m 13.49m	13.54m	13.50m	13.47m 13.47m	13.42m 13.42m	13.36m 13.36m	13.29m 13.29m	13.24m

Porositi :



**Bashkia Shkodër**

Projektoi:

**"LENI-ING" sh.p.k**  
&  
**"ANGERBA" sh.p.k**

Adresa: Rr. Uran Pano, Pallati 12 kat, Kati 2  
Mobile: 0682042270  
Email: leni-ing@hotmail.com

Objekti: **Rikonstruksion Rruga "Memej"**

Faza: **Projekt - Zbatim**

Emërtimi i Fletës:	Shkalla:	Tiranë 2023
PROFILI GJATESORE	Sh V 1:1000 Sh H 1:100	PGJ KUZ



PUSETE TIP D=100cm  
PER TUBA (THELLESIA MBI 2.4m)

PRERJA 1-1  
SH.1:50

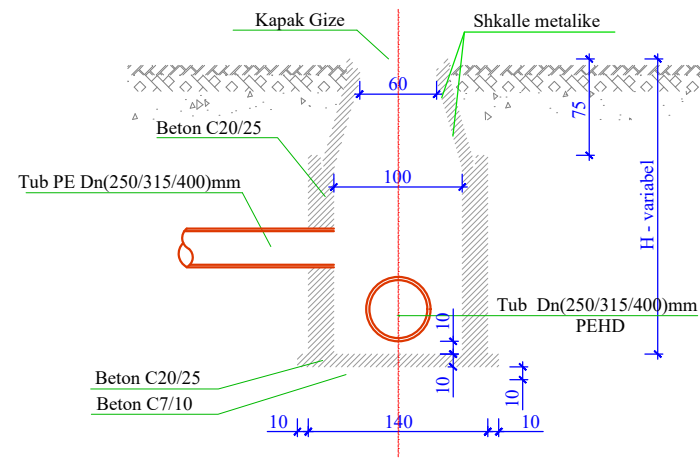

PLAN  
SH.1:50

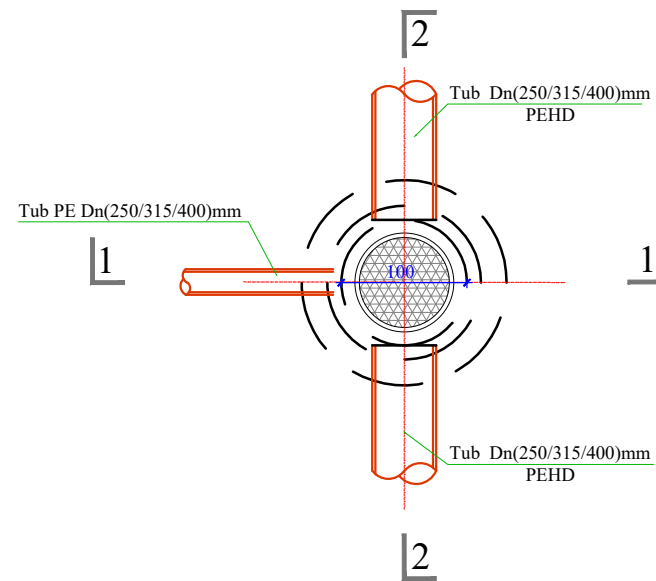

PRERJA 2-2  
SH.1:50

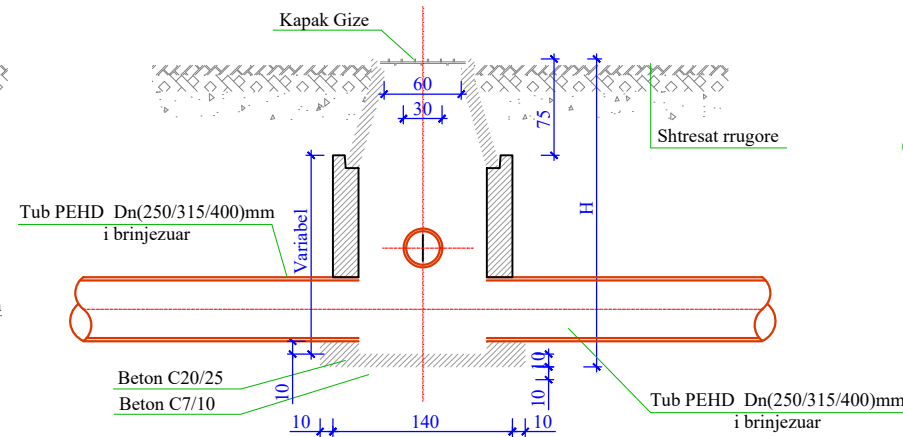

SPIRALI I JASHEM SH.1:20

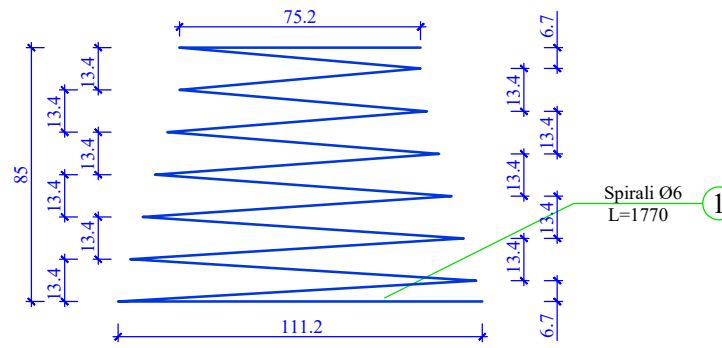

SPIRALI I BRENDESHEM SH.1:20

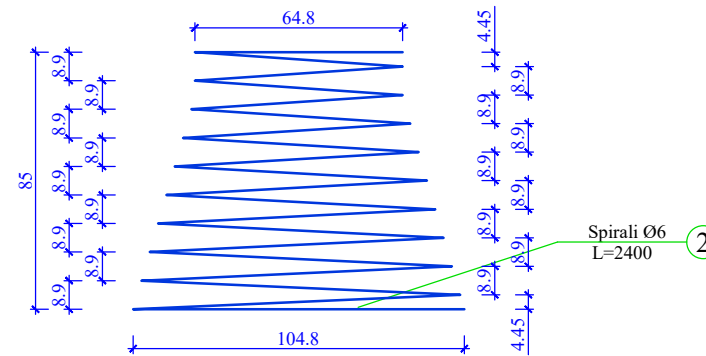

ELEMENT BETONI  
SH.1:20

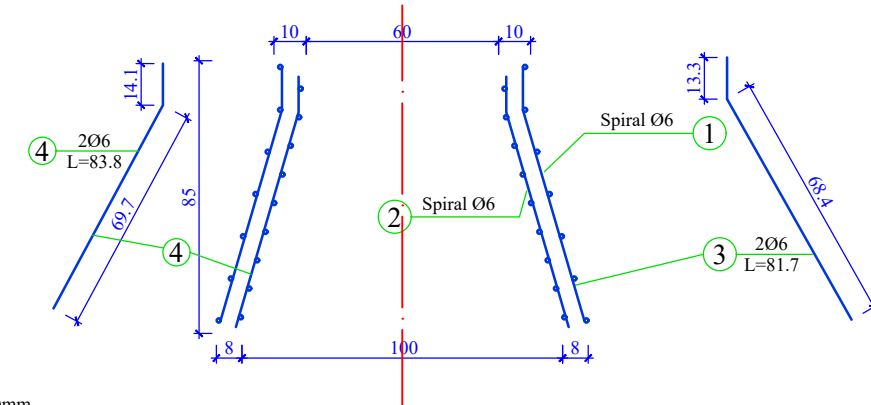

PLAN  
SH.1:20

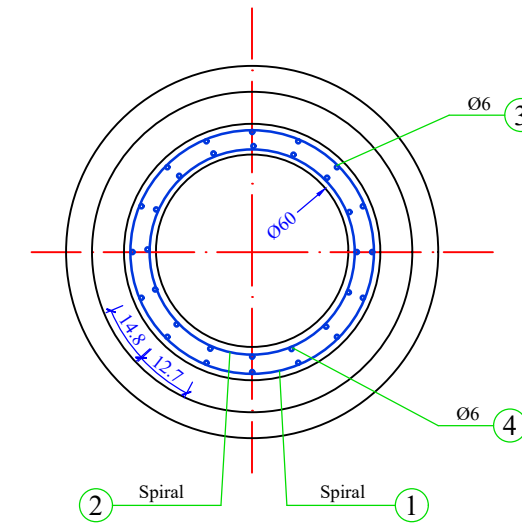

**SHËNIM:**

1. Numri i degëve të kolektorëve dhe pozicionimi i tyre do të merret sipas planimetrisë së rrjetit të K.U.SH.
2. Lartësia e pusëtës do të merret sipas profilit gjatësor të K.U.SH.
3. Për realizimin e pusëtës do të përdoret beton C20/25.
4. Poshtë pusëtës do të vendoset shtresë 10cm beton C7/10 dhe nën të 10cm shtresë çakëll ose zhavor.
5. Kapaku i gizës do të ketë diametër Ø60cm dhe do t'i rezistojë një ngarkese jo më të vogël se 15ton.
6. Detajet janë vizatuar në cm.



**Bashkia Shkodër**

## PROJEKT ZBATIMI

### **Rikonstruktion Rruga "Memej"**

- 01- Hoorografia
- 02- Topografia e rruges
- 03- Planimetria e rruges
- 04- Profili Gjatesore
- 05- Profilat Terthore
- 06- Profili Terthore Tip
- 07- KUZ
- 08- KUSH
- 09- Sinjalistika
- 10- Ujesjellesi
- 11- Ndriçimi Rrugor

MIRATOHET  
KRYETARI I BASHKISË  
Z. BARDH SPAHIA

PROJEKTOI:  
"LENI-ING" SH.P.K  
&  
"ANGERBA" SH.P.K

TIRANË 2023

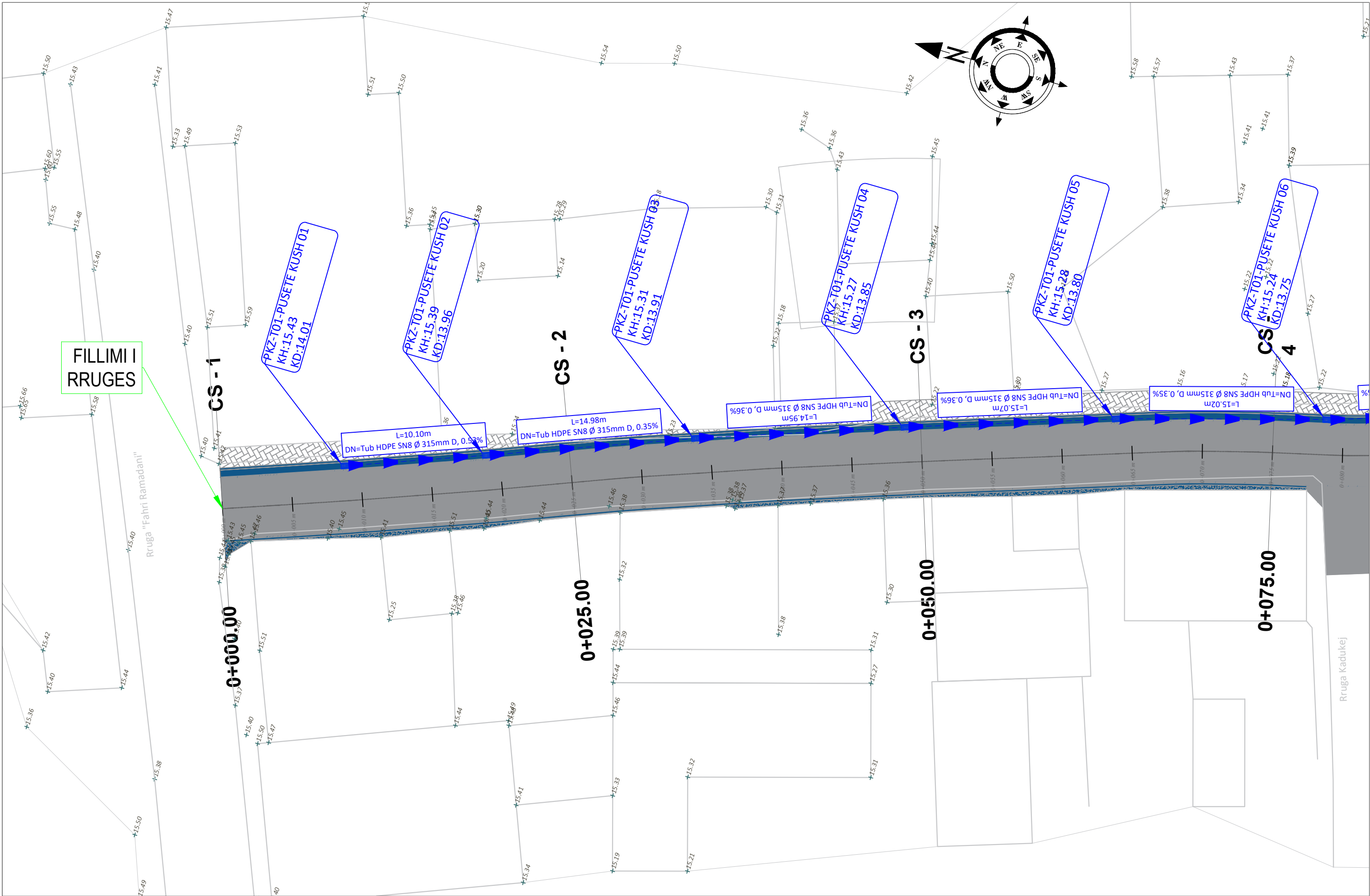

FILLIMI I RRUGES

CS - 1

CS - 2

CS - 3

CS - 4

0+000.00

0+025.00

0+050.00

0+075.00

Rruga "Fahri Ramadani"

Rruga Kadukej

**SHPIJEGUES**

- 156.95 Pike detaje
- 158.0 Izohipse
- Objekt
- Kanal Natyral
- Rrethim
- Mur Rrethues

Porositi :



Projektoi:

"LENI-ING" sh.p.k  
&  
"ANGERBA" sh.p.k

Adresa: Rr. Uran Pano, Pallati 12 kat, Kati 2  
Mobile: 0682042270  
Email: leni-ing@hotmail.com

Objekti: **Rikonstrukcion Rruga "Memej"**

Faza: **Projekt - Zbatim**

Emërtimi i Fletës:	Shkalla:	Tiranë 2023
PLANIMETRIA E RRUGES KUB	Sh 1:250	PL KUB

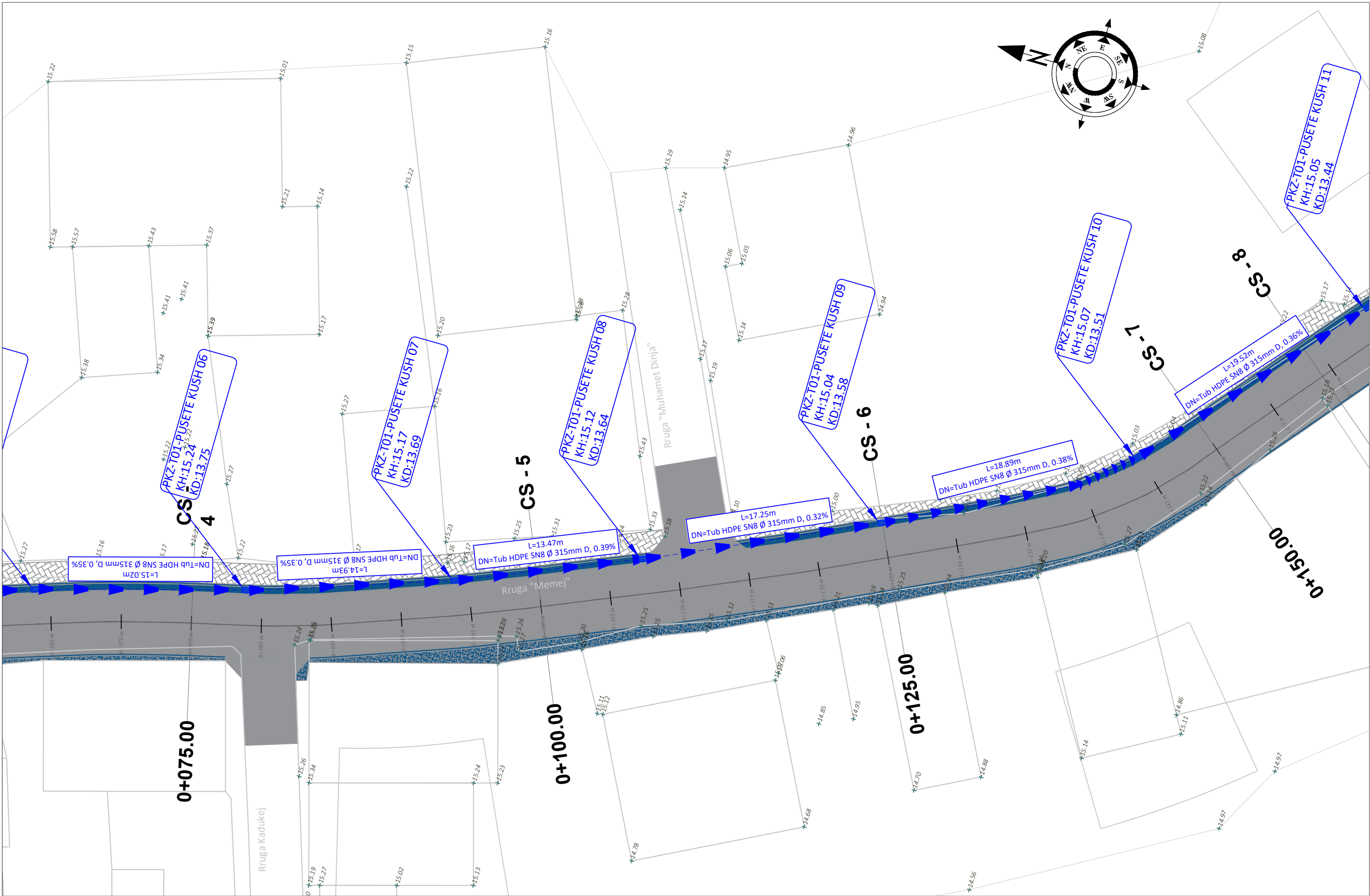

**SHPJEGUES**

	Pike detaje
	Izohipse
	Objekt
	Kanal Natyral
	Rrethim
	Mur Rrethues

Porositi :



**Bashkia Shkodër**

Projektoi:

**"LENI-ING" sh.p.k**  
**&**  
**"ANGERBA" sh.p.k**

Adresa: Rr. Uran Pano, Pallati 12 kat, Kati 2  
 Mobile: 0682042270  
 Email: leni-ing@hotmail.com

Objekti: <b>Rikonstrukcion Rruga "Memej"</b>		
Faza: <b>Projekt - Zbatim</b>		
Emërtimi i Fletës:	Shkalla:	Tiranë 2023
<b>PLANIMETRIA E RRUGES KUB</b>	Sh 1:250	<b>PL KUB (2)</b>

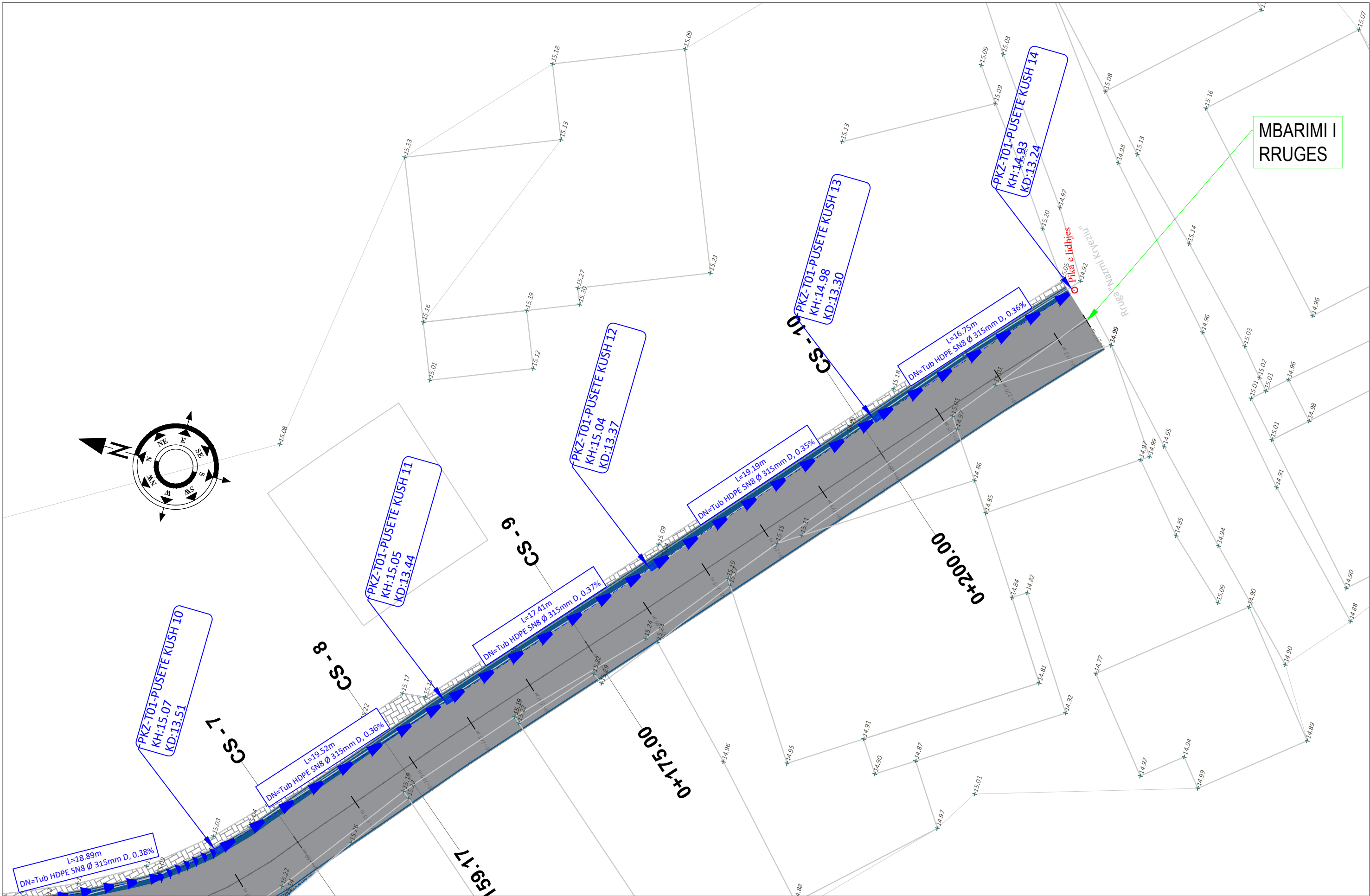

MBARIMI I RRUGES

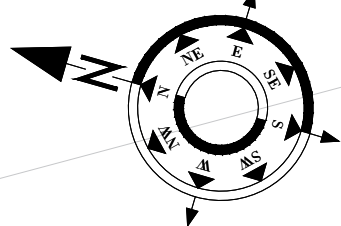

**SHPJEGUES**

	Pike detaje
	Izohipse
	Objekt
	Kanal Natyral
	Rrethim
	Mur Rrethues

Porositi :



**Bashkia Shkodër**

Projektoi:

**"LENI-ING" sh.p.k**  
**&**  
**"ANGERBA" sh.p.k**

Adresa: Rr. Uran Pano, Pallati 12 kat, Kati 2  
 Mobile: 0682042270  
 Email: leni-ing@hotmail.com

Objekti: <b>Rikonstrukcion Rruga "Memej"</b>		
Faza: <b>Projekt - Zbatim</b>		
Emërtimi i Fletës:	Shkalla:	Tiranë 2023
<b>PLANIMETRIA E RRUGES KUB</b>	Sh 1:250	<b>PL KUB (3)</b>

PROFILI GJATESOR  
Aksi i Rruges Memej  
SH\_H - 1:1000  
SH\_V - 1:100

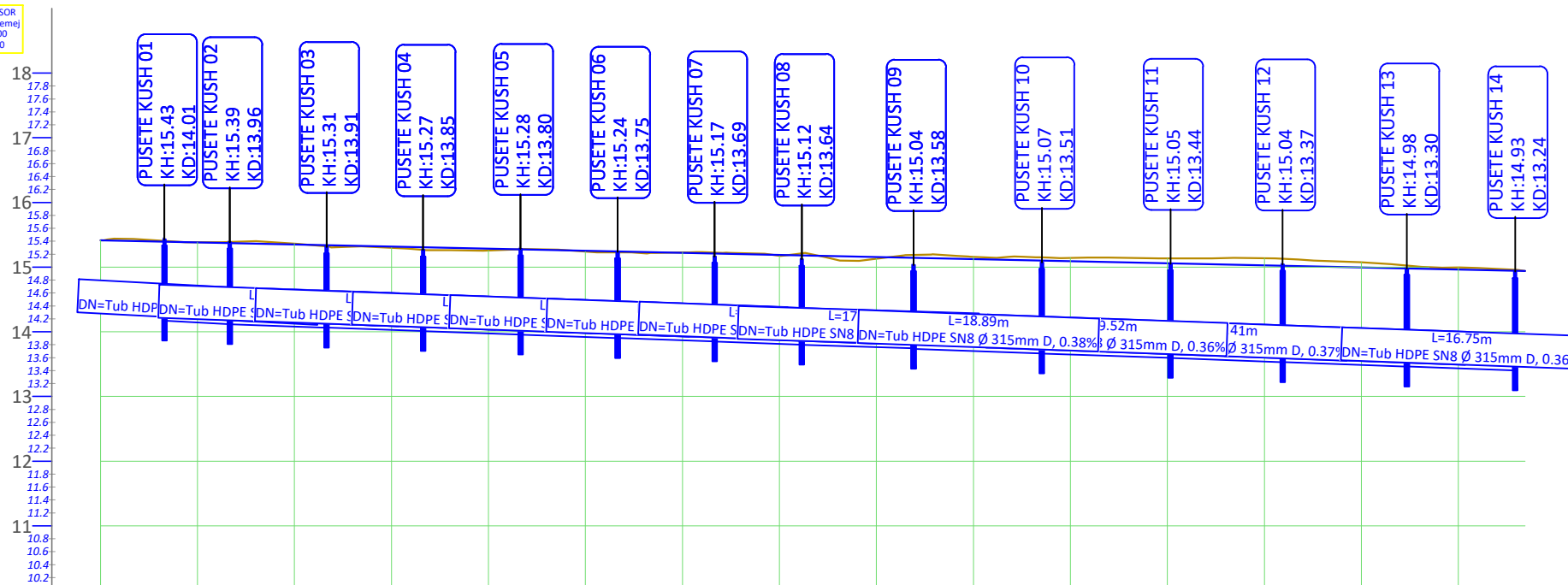

Gjatesia (Li)	L= 10.1m	L= 15.0m	L= 15.0m	L= 15.1m	L= 15.0m	L= 14.9m	L= 13.5m	L= 17.3m	L= 18.9m	L= 19.5m	L= 17.4m	L= 19.2m	L= 16.8m
Nr.Pusetes	D= 315mm	D= 315mm	D= 315mm	D= 315mm	D= 315mm	D= 315mm	D= 315mm	D= 315mm	D= 315mm	D= 315mm	D= 315mm	D= 315mm	D= 315mm
Kuote Tubi (Rrjedhes)	14.01m	13.96m	13.91m	13.85m	13.80m	13.75m	13.69m	13.64m	13.59m	13.51m	13.44m	13.37m	13.30m
Pjeresia (i%)	i=0.53%	i=0.35%	i=0.36%	i=0.36%	i=0.35%	i=0.35%	i=0.39%	i=0.32%	i=0.38%	i=0.36%	i=0.37%	i=0.35%	i=0.36%

Porositi :



**Bashkia Shkodër**

Projektoi:

**"LENI-ING" sh.p.k**  
&  
**"ANGERBA" sh.p.k**

Adresa: Rr. Uran Pano, Pallati 12 kat, Kati 2  
Mobile: 0682042270  
Email: leni-ing@hotmail.com

Objekti: **Rikonstruksion Rruga "Memej"**

Faza: **Projekt - Zbatim**

Emërtimi i Fletës:	Shkalla:	Tiranë 2023
PROFILI GJATESORE KUB	Sh V 1:1000 Sh H 1:100	PGJ KUSH

**PUSETE KONTROLI PER UJRAT E SHIUT  
SH 1:25**

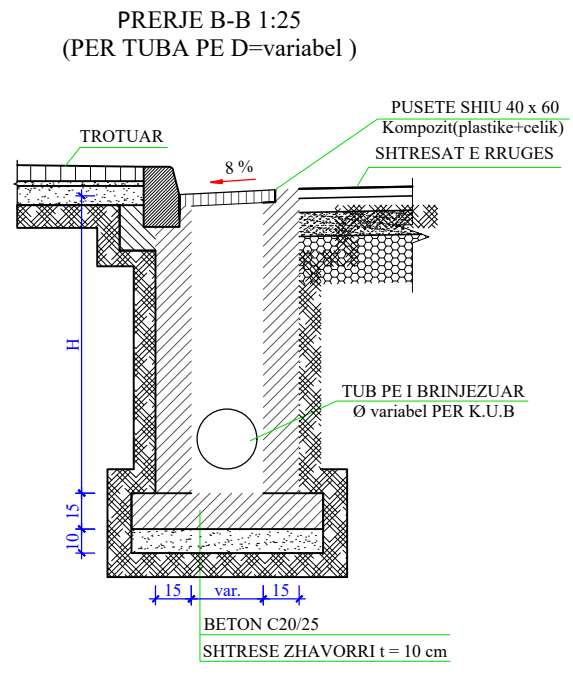
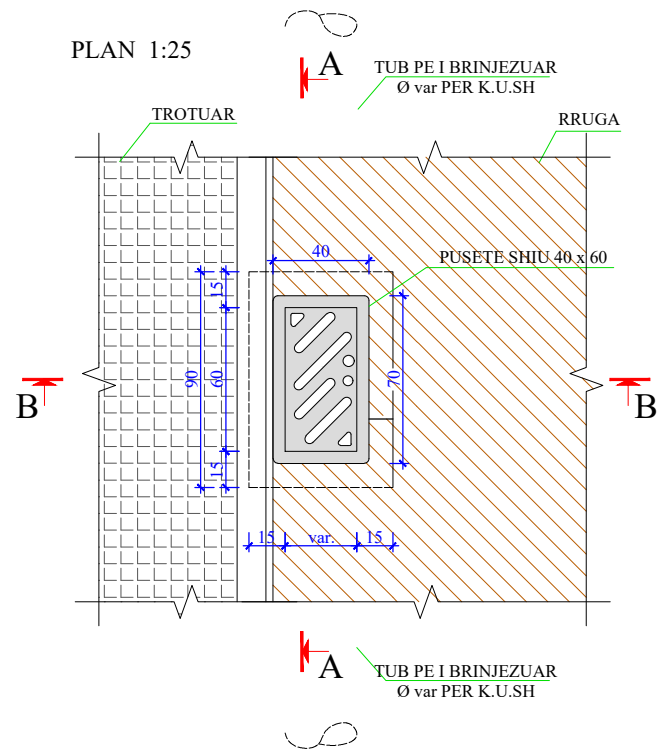

**PRERJE TERTHORE KANALI PER TUBACIONET K.U.SH  
SH 1:25**

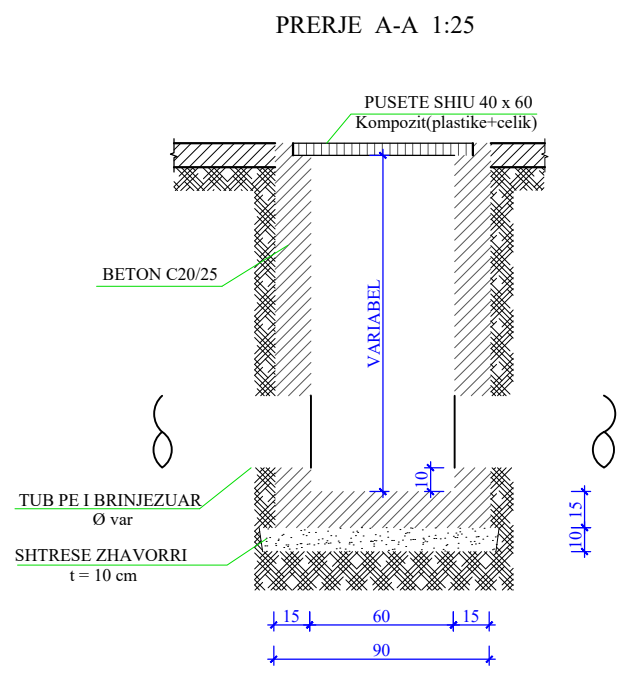
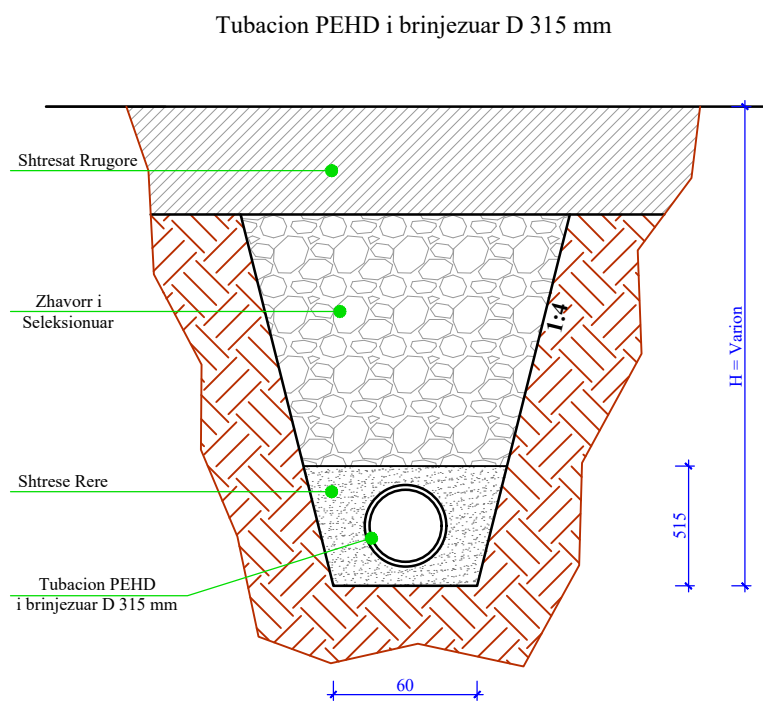

Porositi :  <b>Bashkia Shkodër</b>	Projektoi: <b>"LENI-ING" sh.p.k</b> & <b>"ANGERBA" sh.p.k</b> Adresa: Rr. Uran Pano, Pallati 12 kat, Kati 2 Mobile: 0682042270 Email: leni-ing@hotmail.com	Objekti: <b>Rikonstruksion Rruga "LULAJ"</b>	
		Faza: <b>Projekt - Zbatim</b>	
Emërtimi i Fletës: <b>DETAJE KUSH</b>	Shkalla:	Tiranë 2023	
		KUSH	



**Bashkia Shkodër**

## PROJEKT ZBATIMI

### **Rikonstruktion Rruga "Memej"**

- 01- Hoorografia
- 02- Topografia e rruges
- 03- Planimetria e rruges
- 04- Profili Gjatesore
- 05- Profilat Terthore
- 06- Profili Terthore Tip
- 07- KUZ
- 08- KUSH
- 09- Sinjalistika
- 10- Ujesjellesi
- 11- Ndriçimi Rrugor

MIRATOHET  
KRYETARI I BASHKISË  
Z. BARDH SPAHIA

PROJEKTOI:  
"LENI-ING" SH.P.K  
&  
"ANGERBA" SH.P.K

TIRANË 2023



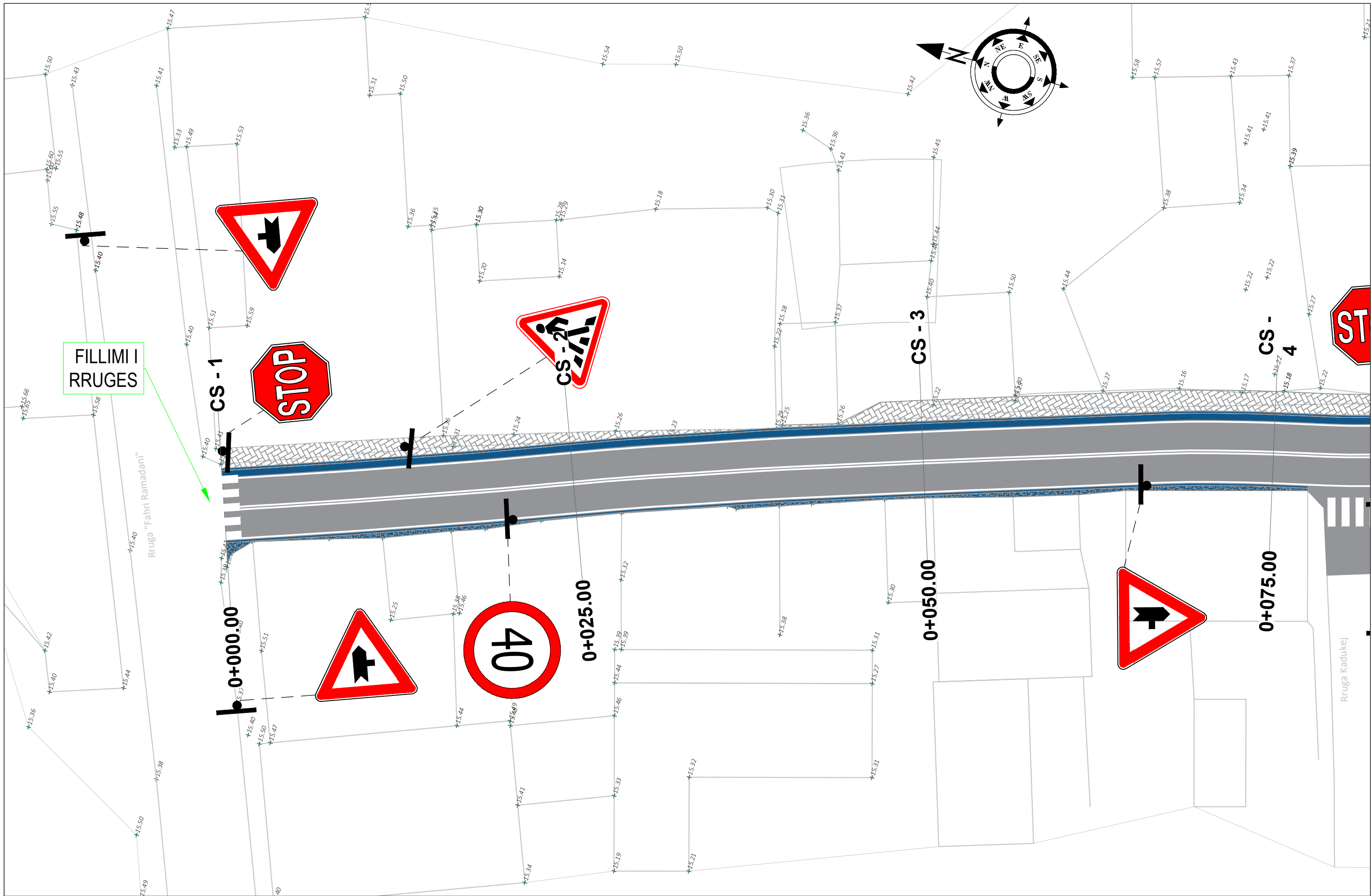

Porositi :



**Bashkia Shkodër**

Projektoi:

**"LENI-ING" sh.p.k**  
**&**  
**"ANGERBA" sh.p.k**

Adresa: Rr. Uran Pano, Pallati 12 kat, Kati 2  
 Mobile: 0682042270  
 Email: leni-ing@hotmail.com

Objekti: <b>Rikonstrukcion Rruga "Memej"</b>		
Faza: <b>Projekt - Zbatim</b>		
Emërtimi i Fletës:	Shkalla:	Tiranë 2023
<b>PLANIMETRIA SINJALISTIKA</b>	Sh 1:250	SIG

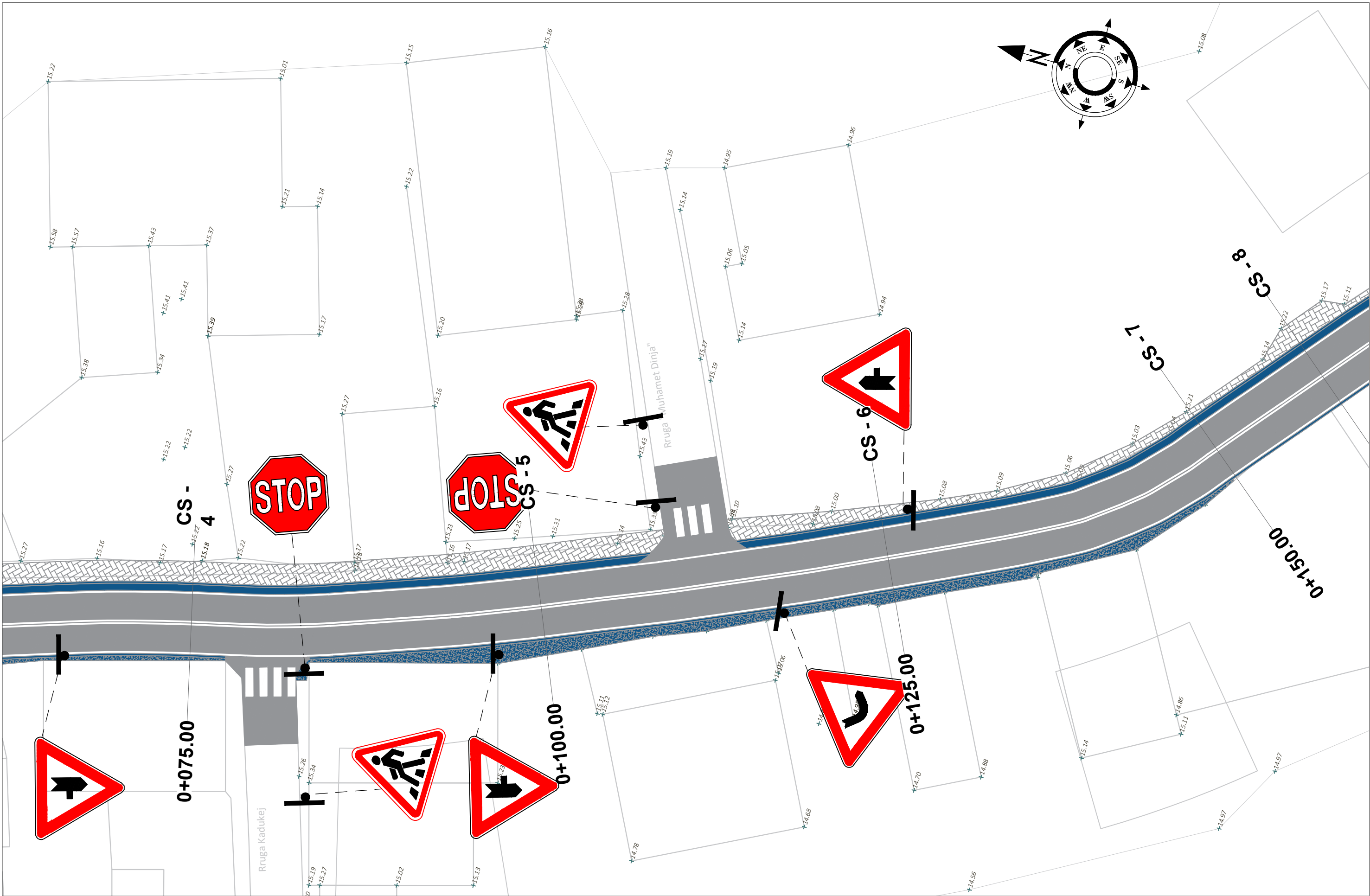
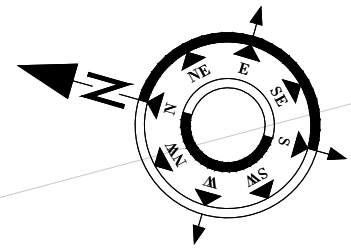

Porositi :



**Bashkia Shkodër**

Projektoi:

**"LENI-ING" sh.p.k**  
**&**  
**"ANGERBA" sh.p.k**

Adresa: Rr. Uran Pano, Pallati 12 kat, Kati 2  
 Mobile: 0682042270  
 Email: leni-ing@hotmail.com

Objekti: <b>Rikonstrukcion Rruga "Memej"</b>		
Faza: <b>Projekt - Zbatim</b>		
Emërtimi i Fletës:	Shkalla:	Tiranë 2023
PLANIMETRIA SINJALISTIKA	Sh 1:250	SIG (2)

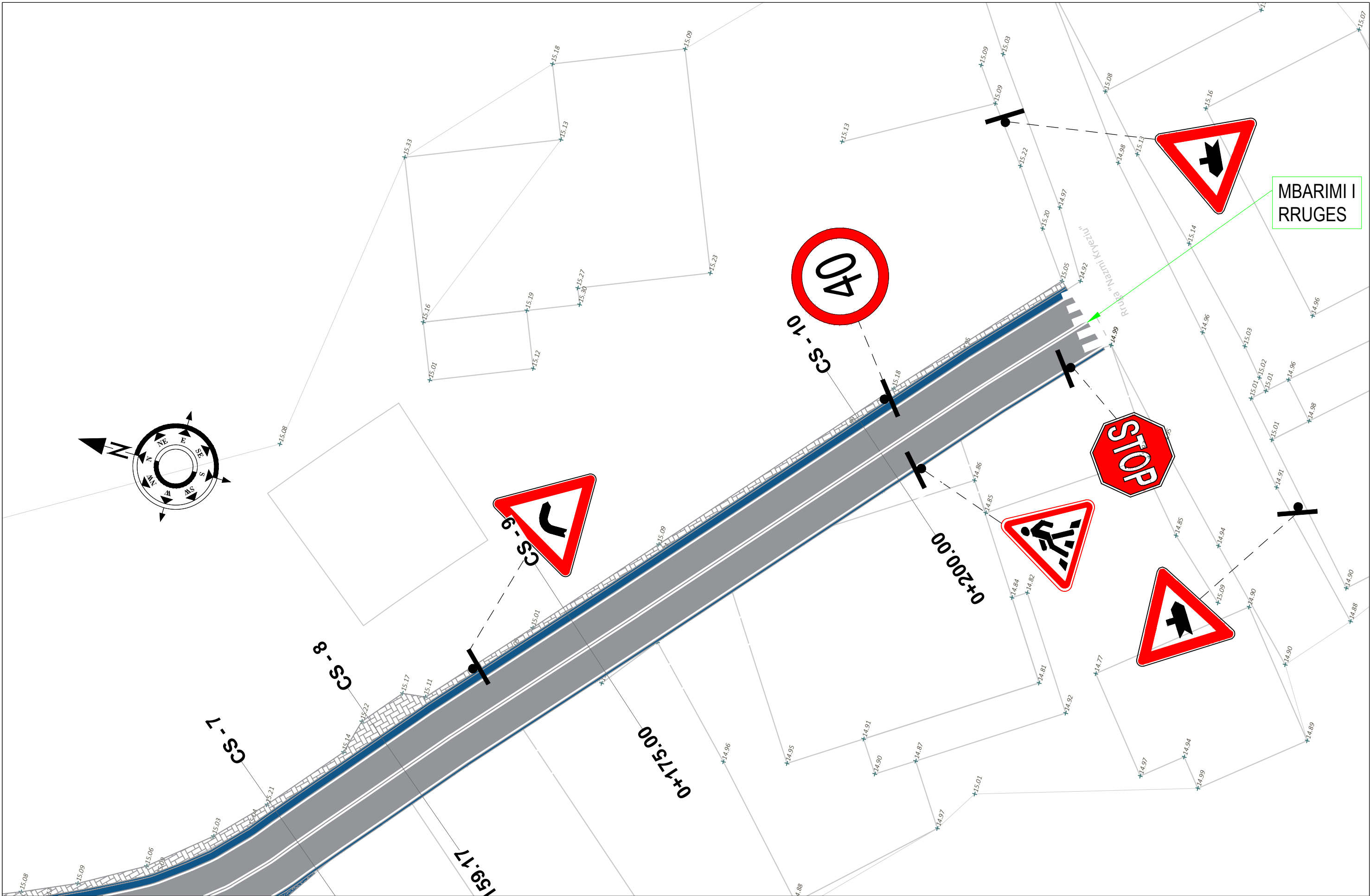

Porositi :



**Bashkia Shkodër**

Projektoi:

**"LENI-ING" sh.p.k**  
**&**  
**"ANGERBA" sh.p.k**

Adresa: Rr. Uran Pano, Pallati 12 kat, Kati 2  
 Mobile: 0682042270  
 Email: leni-ing@hotmail.com

Objekti: <b>Rikonstrukcion Rruga "Memej"</b>		
Faza: <b>Projekt - Zbatim</b>		
Emërtimi i Fletës:	Shkalla:	Tiranë 2023
<b>PLANIMETRIA SINJALISTIKA</b>	Sh 1:250	<b>SIG (3)</b>

# VENDOSJA E TABELAVE RRUGORE

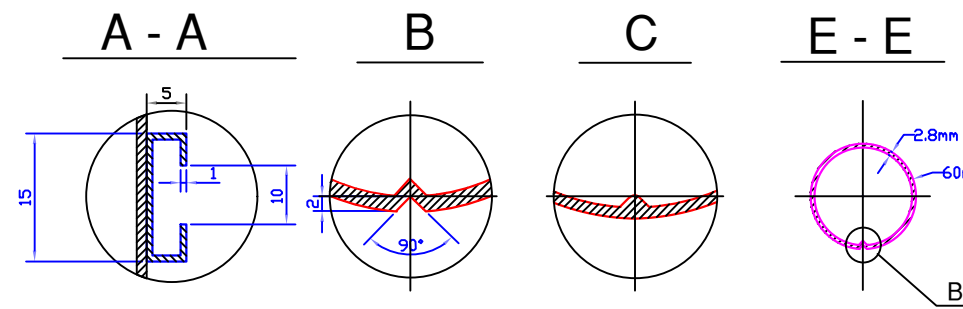
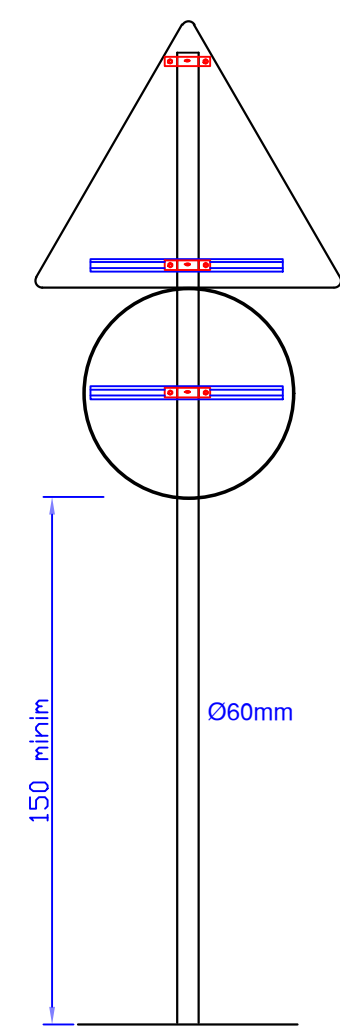
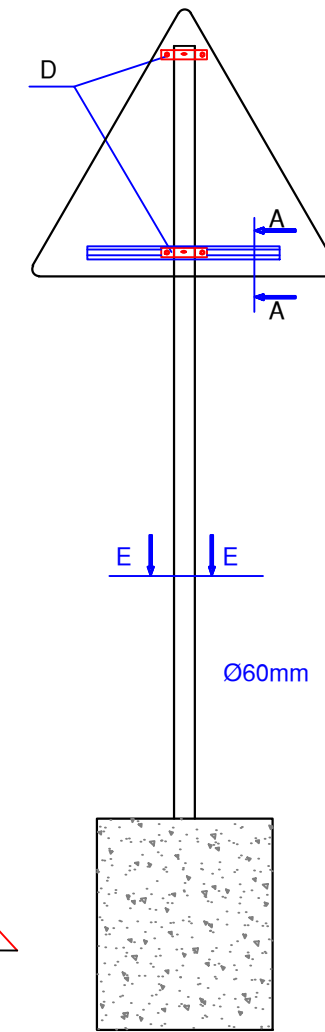
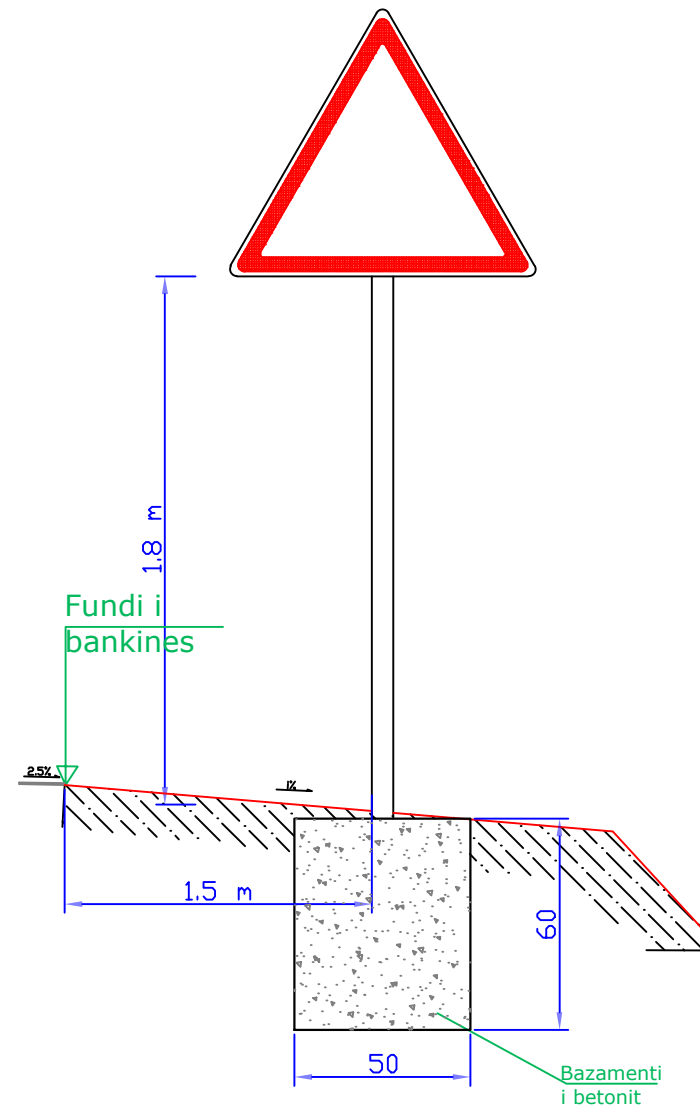
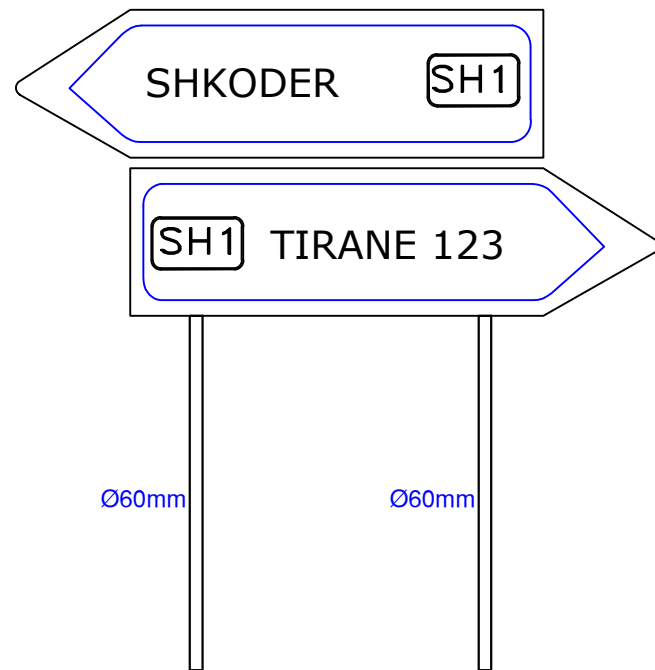
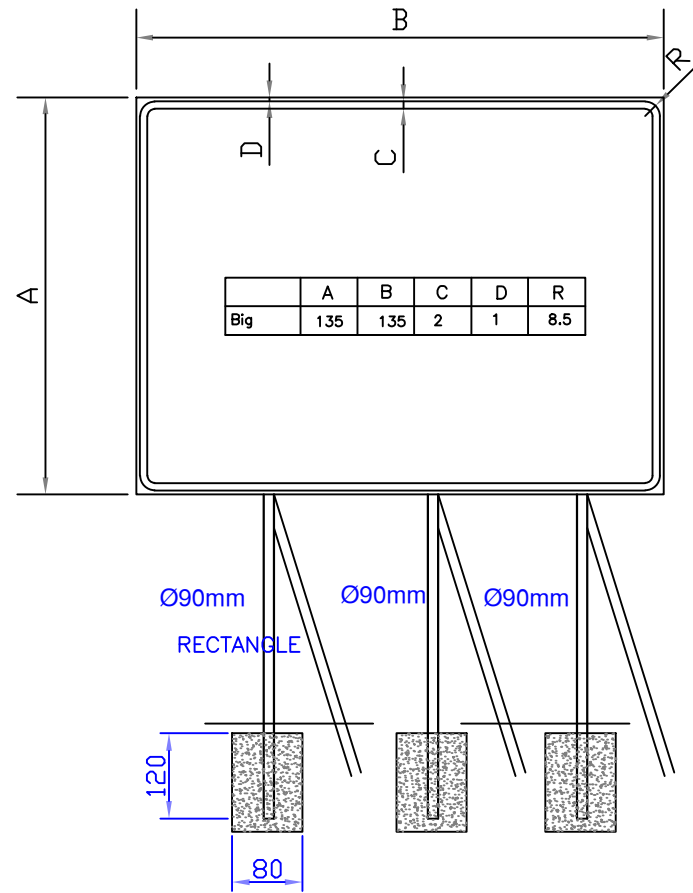

# PERMASAT E TABELAVE RRUGORE

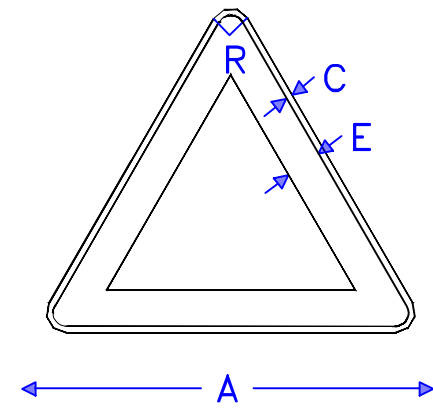

A	C	E	R
90	1.5	8	4.5

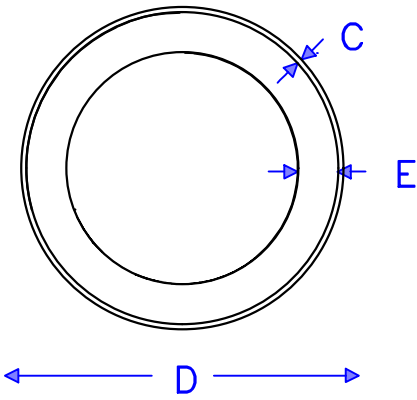

C	D	E
1	60	7.5

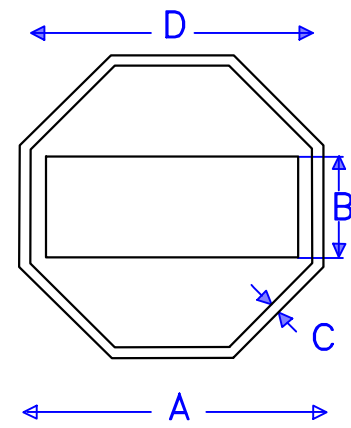

A	C	E	D
90	30	3	75
Dim vogel			
60	20	2	50

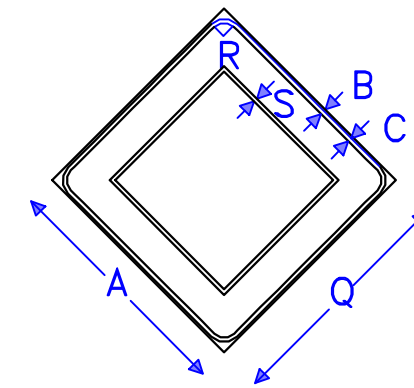

A	B	C	Q	R	S
60	0.5	1	40	3.5	11

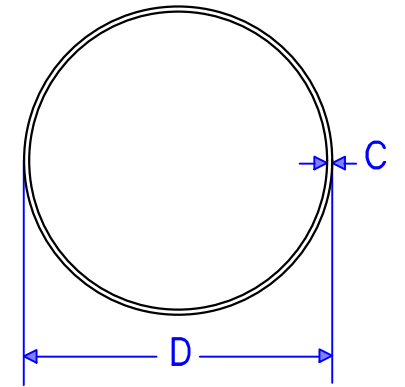

C	D
1	60
Dim vogel	
0.8	40

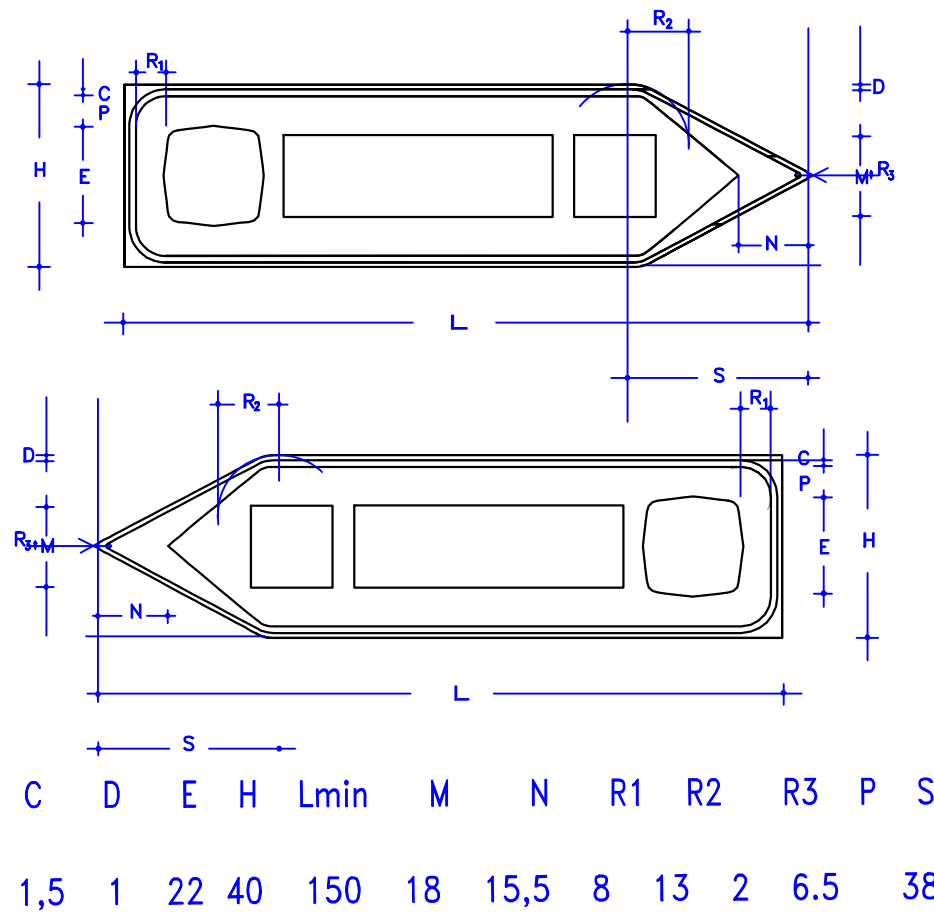

C	D	E	H	Lmin	M	N	R1	R2	R3	P	S
1,5	1	22	40	150	18	15,5	8	13	2	6.5	38

## TABELA KUADRATIKE

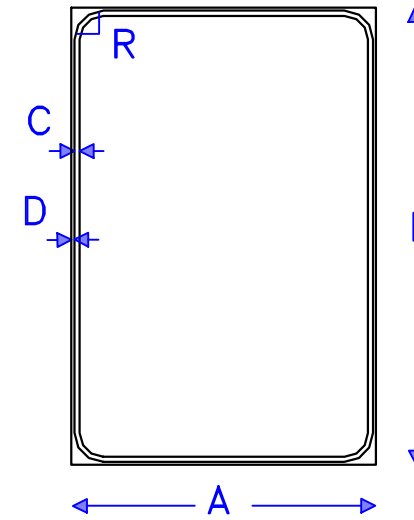

A	B	C	D	R
90	135	1.6	0.8	7
90	135	1.6	0.8	7

Modular i tabelave terkendore

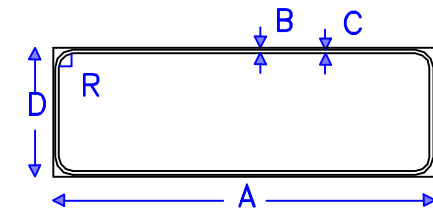

A	B	C	D	R
80	0.4	0.8	27	3

Porositi :



Projektoi:

"LENI-ING" sh.p.k  
&  
"ANGERBA" sh.p.k

Adresa: Rr. Uran Pano, Pallati 12 kat, Kati 2  
Mobile: 0682042270  
Email: leni-ing@hotmail.com

Objekti: Rikonstruksion Rruga "Memej"

Faza: Projekt - Zbatim

Emërtimi i Fletës:  
DETAJE  
TABELASH

Shkalla:

Tiranë 2023

DS (2)

## TABELA NDALUESE

Kufizim maksimal i shpejtesise

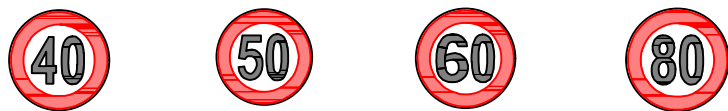

Fig II-50

Fundi i kufizimit te shpejtesise



Fig II-47

Ndalim parakalimi



Fig II-48

## TABELAT E RREZIKUT

Kthese



Fig II-4 Fig II-5

Kthese dyfishe



Fig II-6 Fig II-7

Vendkalim kembesoresh



Fig II-13

Femijet



Fig II-23

## TABELAT E DETYRIMIT

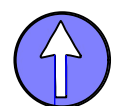

Fig II-80a



Fig II-81a

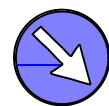
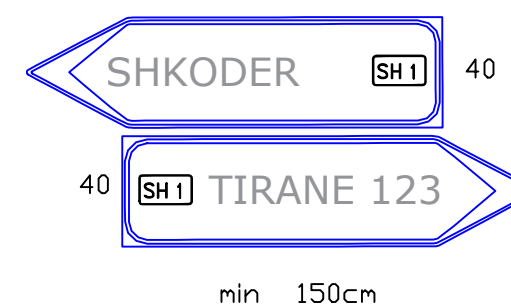

Fig II-82b

## TABELAT E DREJTIMIT

Fig II-249



## TABELAT E PERPARSISE



Fig II-43 a



Fig II-43 b



Fig II-43 c

Ndal dhe jep perparsi

Jep perparsi ne njekaline te alternuara

E drejft perparsie

E drejfte perparsie ne njekaline te alternuara



Fig II-37



Fig II-41

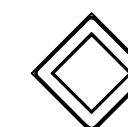

Fig II-44

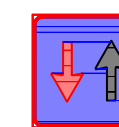

Fig II-45

Porositi :



Projektoi:

"LENI-ING" sh.p.k  
&  
"ANGERBA" sh.p.k

Adresa: Rr. Uran Pano, Pallati 12 kat, Kati 2  
Mobile: 0682042270  
Email: leni-ing@hotmail.com

Objekti: Rikonstruksion Rruga "Memej"

Faza: Projekt - Zbatim

Emërtimi i Fletës:  
DETAJE  
TABELASH

Shkalla:

Tiranë 2023

DS (3)



**Bashkia Shkodër**

## PROJEKT ZBATIMI

### **Rikonstruktion Rruga "Memej"**

- 01- Hoorografia
- 02- Topografia e rruges
- 03- Planimetria e rruges
- 04- Profili Gjatesore
- 05- Profilat Terthore
- 06- Profili Terthore Tip
- 07- KUZ
- 08- KUSH
- 09- Sinjalistika
- 10- Ujesjellesi
- 11- Ndriçimi Rrugor

MIRATOHET  
KRYETARI I BASHKISË  
Z. BARDH SPAHIA

PROJEKTOI:  
"LENI-ING" SH.P.K  
&  
"ANGERBA" SH.P.K

TIRANË 2023

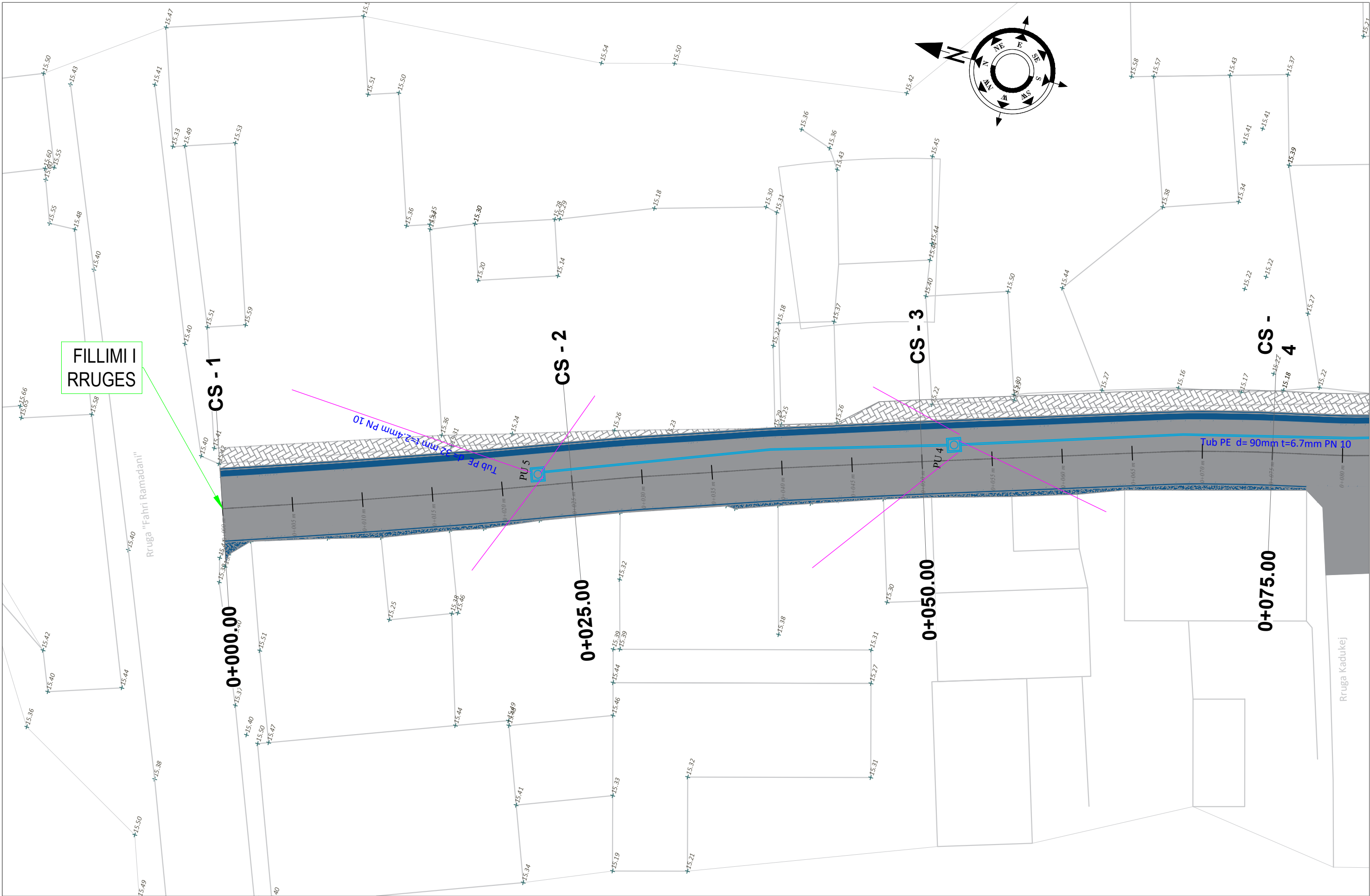

**SHPJEGUES**

	156.95	Pike detaje
	158.0	Izohipse
		Objekt
		Kanal Natyral
		Rrrethim
		Mur Rrethues

Porositi :



**Bashkia Shkodër**

Projektoi:

**"LENI-ING" sh.p.k**  
**&**  
**"ANGERBA" sh.p.k**

Adresa: Rr. Uran Pano, Pallati 12 kat, Kati 2  
 Mobile: 0682042270  
 Email: leni-ing@hotmail.com

Objekti: <b>Rikonstruksion Rruga "Memej"</b>		
Faza: <b>Projekt - Zbatim</b>		
Emërtimi i Fletës:	Shkalla:	Tiranë 2023
<b>PLANIMETRIA E UJESJELLESIT</b>	Sh 1:250	PL US



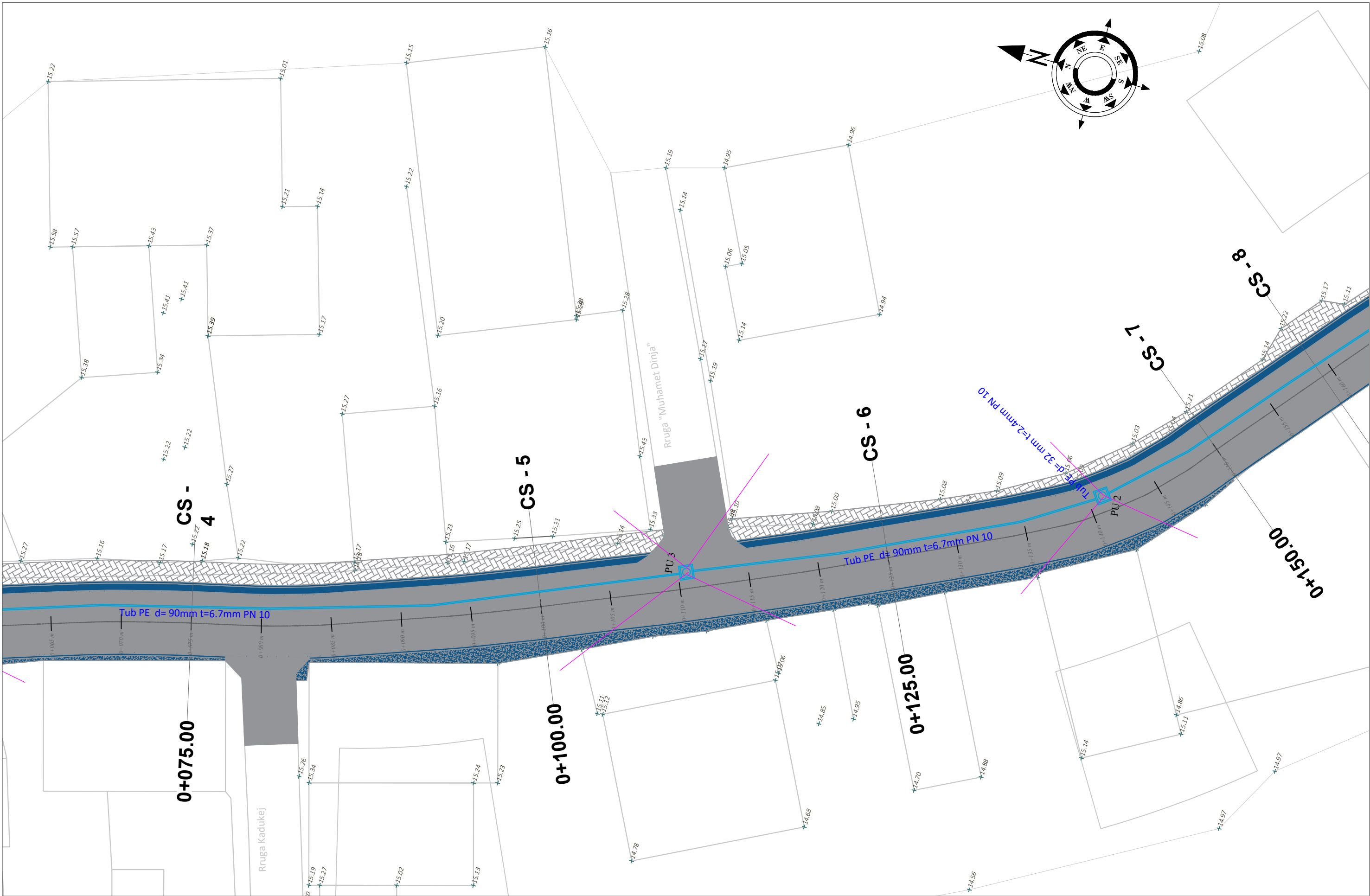

**SHPJEGUES**

- 156.95 Pike detaje
- 158.0 Izohipse
- Objekt
- Kanal Natyral
- Rrethim
- Mur Rrethues

Porositi :



**Bashkia Shkodër**

Projektoi:

**"LENI-ING" sh.p.k**  
**&**  
**"ANGERBA" sh.p.k**

Adresa: Rr. Uran Pano, Pallati 12 kat, Kati 2  
 Mobile: 0682042270  
 Email: leni-ing@hotmail.com

Objekti: <b>Rikonstrukcion Rruga "Memej"</b>		
Faza: <b>Projekt - Zbatim</b>		
Emërtimi i Fletës: <b>PLANIMETRIA E UJESJELLESIT</b>	Shkalla: <b>Sh 1:250</b>	Tiranë 2023 <b>PL US 2</b>

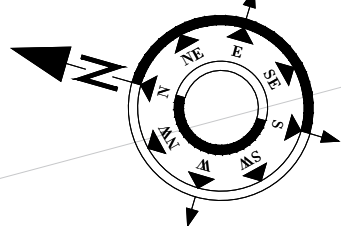
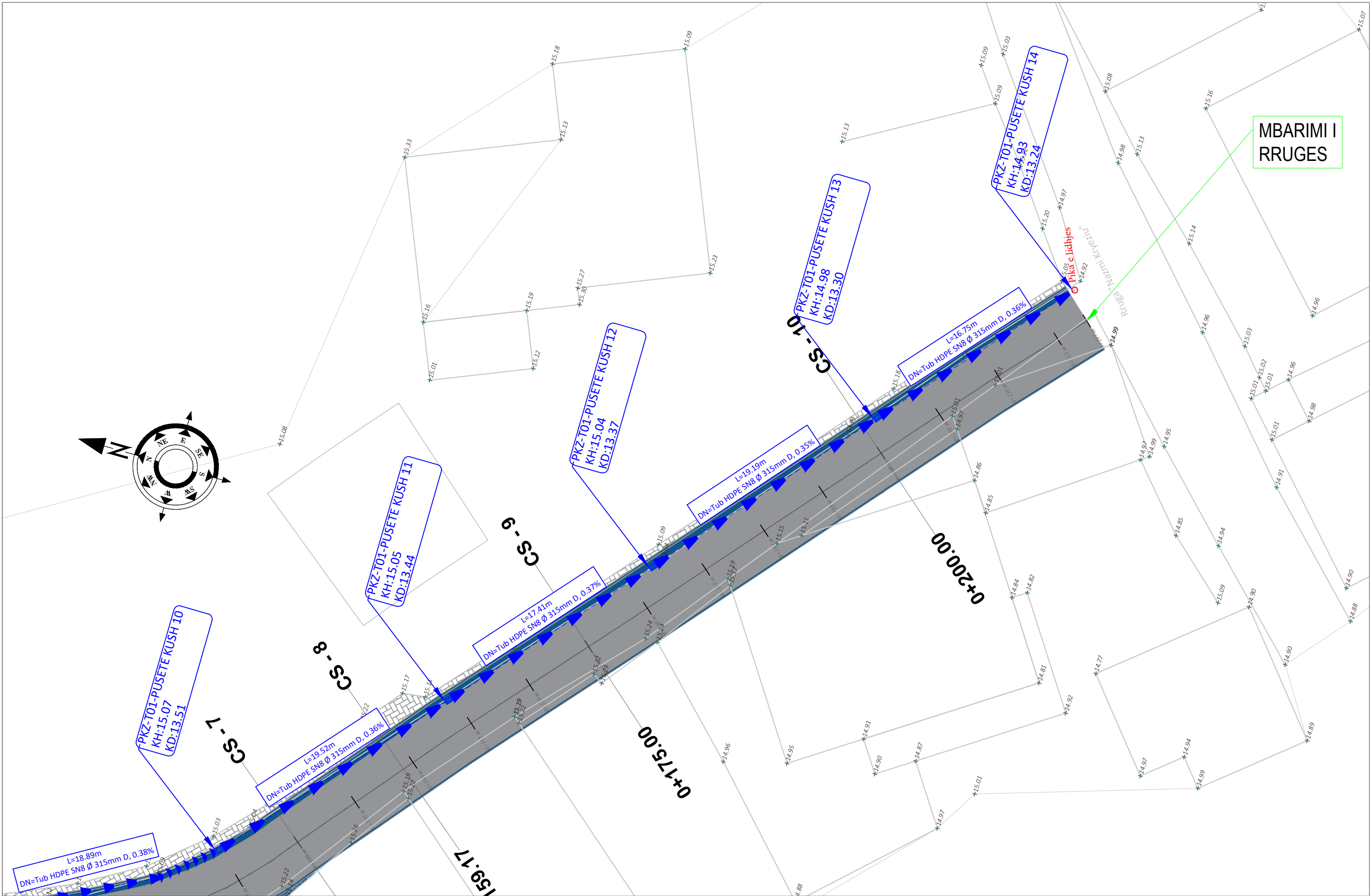

**SHPJEGUES**

- 156.95 Pike detaje
- 158.0 Izohipse
- Objekt
- Kanal Natyral
- Rrethim
- Mur Rrethues

Porositi :



**Bashkia Shkodër**

Projektoi:

**"LENI-ING" sh.p.k**  
**&**  
**"ANGERBA" sh.p.k**

Adresa: Rr. Uran Pano, Pallati 12 kat, Kati 2  
 Mobile: 0682042270  
 Email: leni-ing@hotmail.com

Objekti: <b>Rikonstrukcion Rruga "Memej"</b>		
Faza: <b>Projekt - Zbatim</b>		
Emërtimi i Fletës: <b>PLANIMETRIA E UJESJELLESIT</b>	Shkalla: <b>Sh 1:250</b>	Tiranë 2023 <b>PL US 3</b>



**Bashkia Shkodër**

## PROJEKT ZBATIMI

### **Rikonstruktion Rruga "Memej"**

- 01- Hoorografia
- 02- Topografia e rruges
- 03- Planimetria e rruges
- 04- Profili Gjatesore
- 05- Profilat Terthore
- 06- Profili Terthore Tip
- 07- KUZ
- 08- KUSH
- 09- Sinjalistika
- 10- Ujesjellesi
- 11- Ndriçimi Rrugor

MIRATOHET  
KRYETARI I BASHKISË  
Z. BARDH SPAHIA

PROJEKTOI:  
"LENI-ING" SH.P.K  
&  
"ANGERBA" SH.P.K

TIRANË 2023

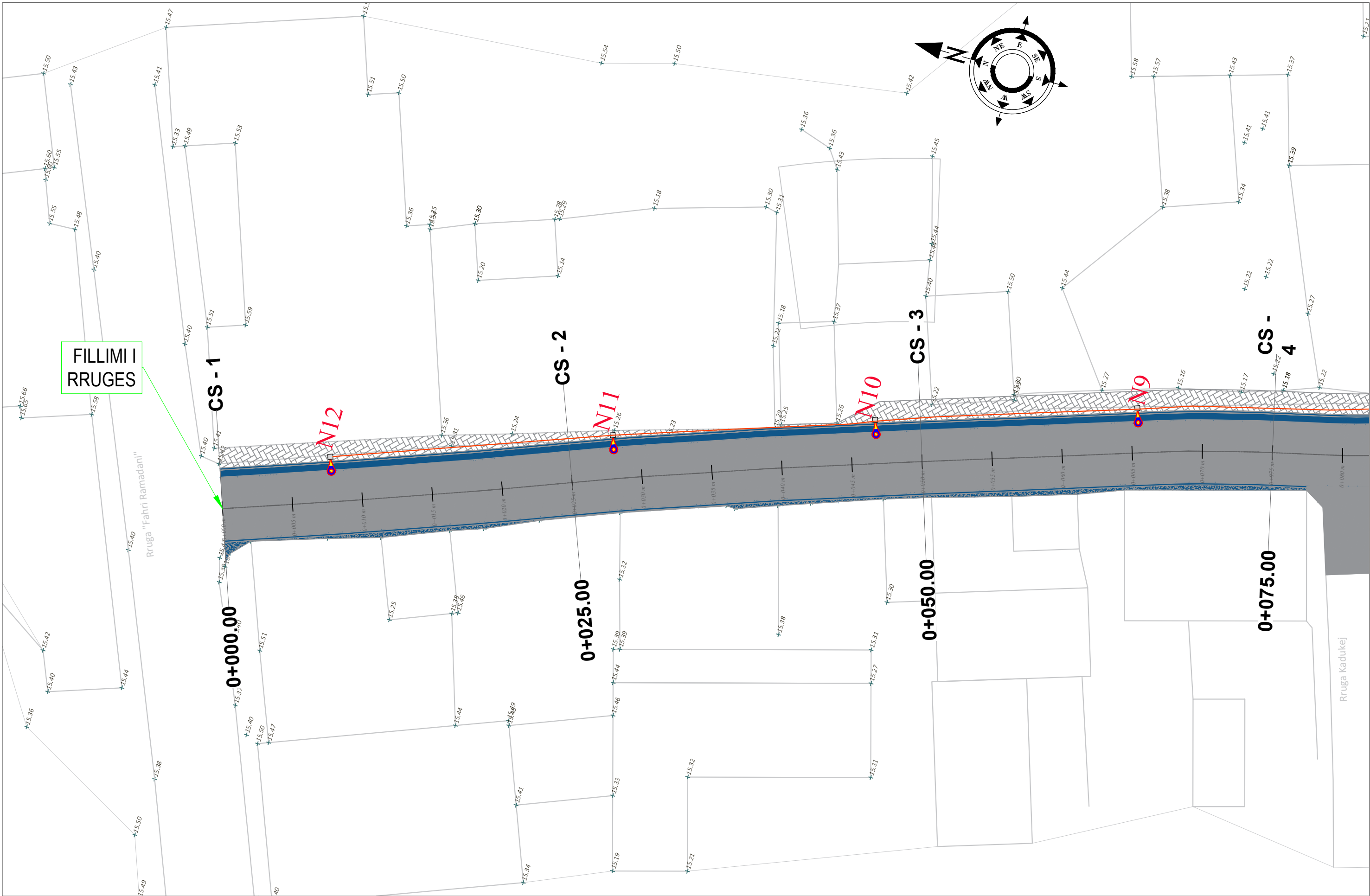

**SHPJEGUES**

- 156.95 Pike detaje
- 158.0 Izohipse
- Objekt
- Kanal Natyral
- Rrethim
- Mur Rrethues

Porositi :



**Bashkia Shkodër**

Projektoi:

**"LENI-ING" sh.p.k**  
**&**  
**"ANGERBA" sh.p.k**

Adresa: Rr. Uran Pano, Pallati 12 kat, Kati 2  
 Mobile: 0682042270  
 Email: leni-ing@hotmail.com

Objekti: <b>Rikonstrukcion Rruga "Memej"</b>		
Faza: <b>Projekt - Zbatim</b>		
Emërtimi i Fletës: <b>PLANIMETRIA E NDRICIMIT</b>	Shkalla: Sh 1:250	Tiranë 2023  PL ND

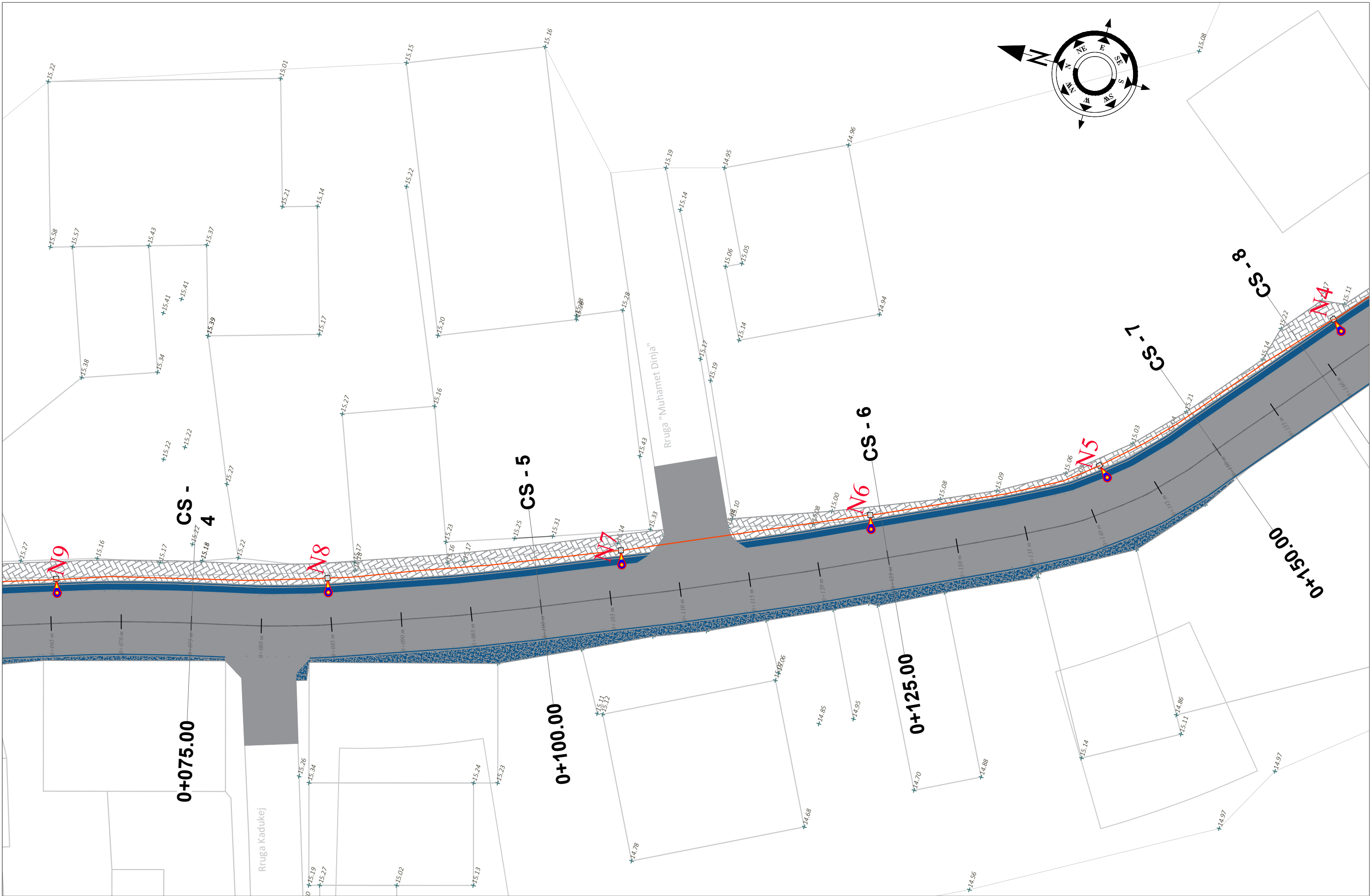

**SHPJEGUES**

- 156.95 Pike detaje
- 158.0 Izohipse
- Objekt
- Kanal Natyral
- Rrethim
- Mur Rrethues

Porositi :



**Bashkia Shkodër**

Projektoi:

**"LENI-ING" sh.p.k**  
**&**  
**"ANGERBA" sh.p.k**

Adresa: Rr. Uran Pano, Pallati 12 kat, Kati 2  
 Mobile: 0682042270  
 Email: leni-ing@hotmail.com

Objekti: <b>Rikonstrukcion Rruga "Memej"</b>		
Faza: <b>Projekt - Zbatim</b>		
Emërtimi i Fletës:	Shkalla:	Tiranë 2023
<b>PLANIMETRIA E NDRICIMIT</b>	Sh 1:250	<b>PL ND 1</b>



MBARIMI I RRUGES

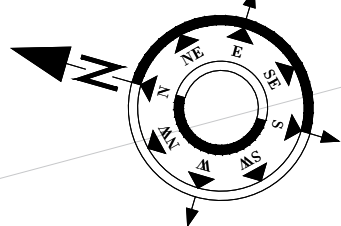

**SHPJEGUES**

	Pike detaje
	Izohipse
	Objekt
	Kanal Natyral
	Rrethim
	Mur Rrethues

Porositi :



**Bashkia Shkodër**

Projektoi:

**"LENI-ING" sh.p.k**  
**&**  
**"ANGERBA" sh.p.k**

Adresa: Rr. Uran Pano, Pallati 12 kat, Kati 2  
 Mobile: 0682042270  
 Email: leni-ing@hotmail.com

Objekti: <b>Rikonstrukcion Rruga "Memej"</b>		
Faza: <b>Projekt - Zbatim</b>		
Emërtimi i Fletës:	Shkalla:	Tiranë 2023
<b>PLANIMETRIA E NDRICIMIT</b>	Sh 1:250	<b>PL ND 2</b>