

**POROSITESI :
BASHKIA BULQIZE**



O B J E K T I : **""Sistemim – Asfaltim i Rruges Lagjja Ruse – Jelle, Fshati Homesh, Shupenze”."**

PROJEKTUES :

"HYDRO-ENG CONSULTING " sh.p.k



"IDEAL CONSTRUCTION & PROJECTION"(I.C.P) sh.p.k



"P.C.S COMPANY " sh.p.k



GRUPI I PROJEKTIMIT

Ing.Hidroteknik Evis QYRKU	Nr. Licence K.1829/2
Ing. Ndertimi Alban DAUTAJ	Nr. Licence K.2232/2
Ing. Ndertimi Pamela KURTULAJ (ALIU)	Nr. Licence K.1474/3
A r k i t e k t Endrit TUZI	Nr. Licence A.0128/6
Ing.Topograf Maksim GEGA	Nr. Licence T.0455/4
Ing.Gjeodet Albin KOCI	Nr. Licence E.1269/2
Ing.Elektrik Edmond PALODHI	Nr. Licence E.1552
Ing.Gjeolog Asllan BASHA	Nr. Licence GJ.0686
Ing.Mjedisi Shpetim CIKU	Nr. Licence A.2443
Ing.Hidroteknik Xhuljana DAUTAJ (SULA)	Nr. Licence K.2232/2
A r k i t e k t Jorida GRABOVARI	Nr. Licence A.2595

FIRMA/VULA

PROJEKTUES: BOE “HYDRO-ENG CONSULTING” sh.p.k & IDEAL CONSTRUCTION & PROJECTION Shpk & “P.C.S COMPANY” Shpk

SUBJEKTI ZHVILLUES: Bashkia Bulqize

Nr. i fletes

A-00

HOROGRAFIA E RRUGES RUSE JELLE SH 1: 1000

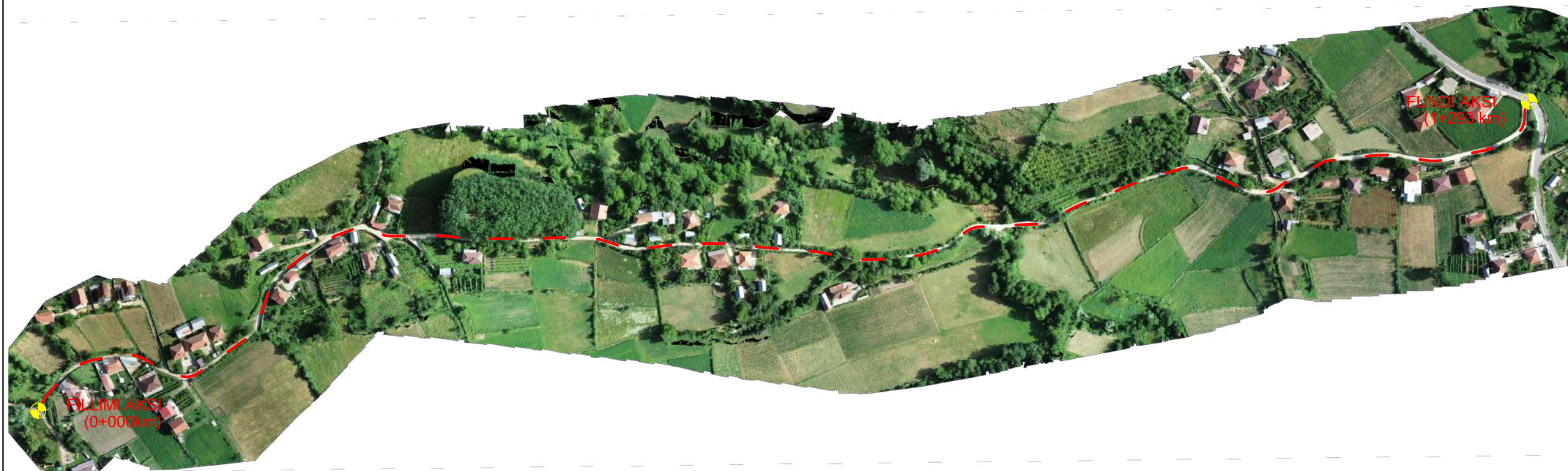

O B J E K T I

SISTEM-ASFALTIM I
RRUGES LAGJA RUSE -
JELLE, FSHATI HOMESH,
SHUPENZE,
BASHKIA BULQIZE

POROSITESI :
BASHKIA BULQIZE



PROJEKTUES :

"HYDRO-ENG CONSULTING"
sh.p.k



"IDEAL CONSTRUCTION
& PROJECTION"(I.C.P) sh.p.k



"P.C.S COMPANY " sh.p.k



GRUPI I PROJEKTIMIT

Ing.Hidroteknik Evis QYRKU	Nr. Licence K.1829/2
Ing. Ndertimi Alban DAUTAJ	Nr. Licence K.2232/2
Ing. Ndertimi Pamela KURTULAJ(ALIU)	Nr. Licence K.1474/3
Arkitekt Endrit TUZI	Nr. Licence A.0128/6
Ing.Topograf Maksim GEGA	Nr. Licence T.0455/4
Ing.Gjeodet Albin KOCI	Nr. Licence E.1269/2
Ing.Elektrik Edmond PALODHI	Nr. Licence E.1552
Ing.Gjeolog Asllan BASHA	Nr. Licence G.J.0686
Ing.Mjedisi Shpetim CIKU	Nr. Licence A.2443
Ing.Hidroteknik Xhuljana DAUTAJ(SULA)	Nr. Licence K.2232/2
Arkitekt Jorida GRABOVARI	Nr. Licence A.2595

FIRMA/VULA

SHENIME

TE DHENA TEKNIKE

FAZA E PROJEKTIT	PROJEKT ZBATIM
TIPI I FLETES	
EMERTIMI I FLETES	PLANMETRIA 1:1000

Nr. i fletes **A-01**

PLANPIKETIMI I RRUGES SH 1: 1000

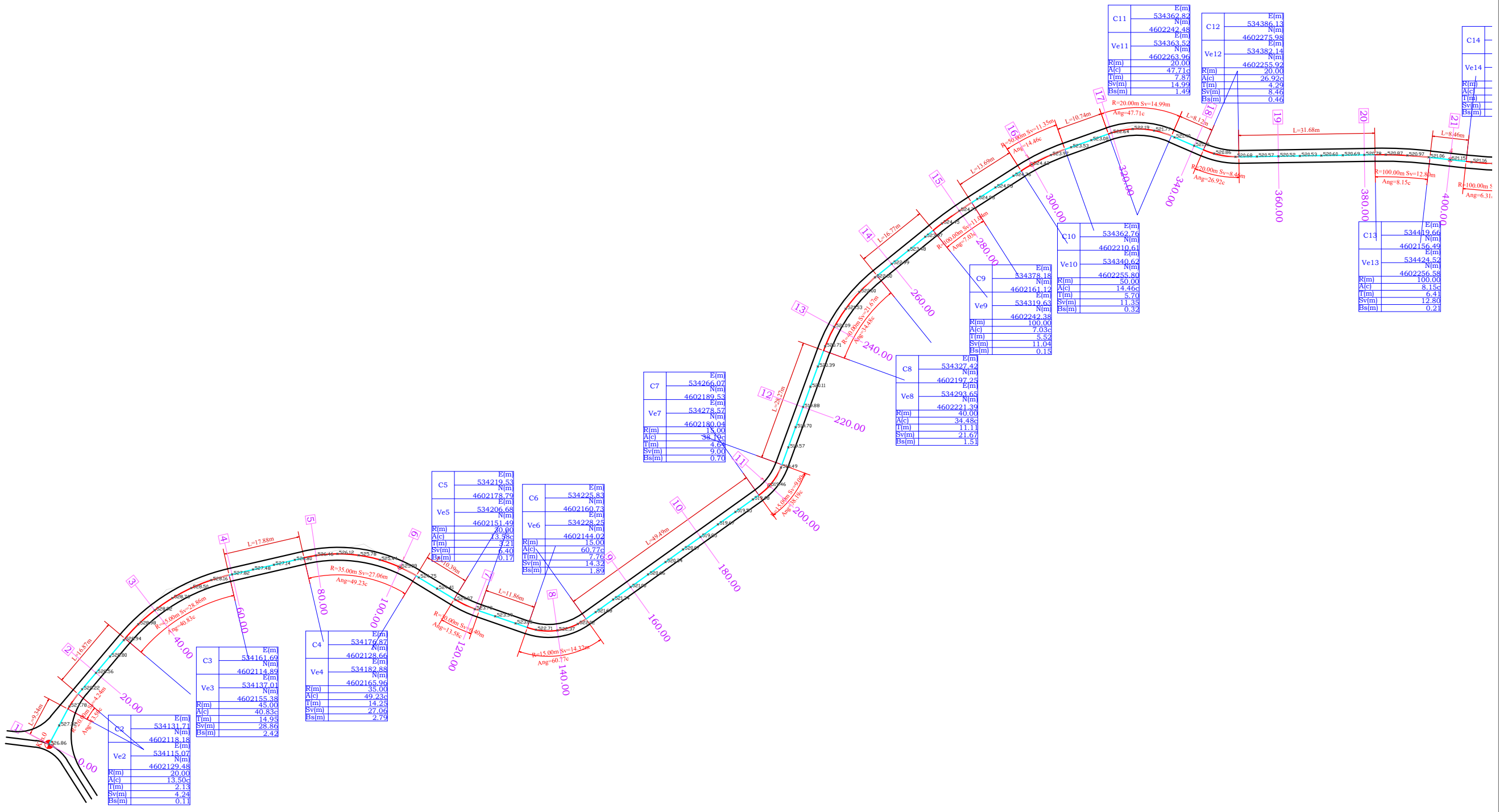

OBJEKTI

SISTEM-ASFALTIM I
RRUGES LAGJA RUSE -
JELLE, FSHATI HOMESH,
SHUPENZE,
BASHKIA BULQIZE

POROSITESI :
BASHKIA BULQIZE



PROJEKTUES :

"HYDRO-ENG CONSULTING"
sh.p.k



"IDEAL CONSTRUCTION
& PROJECTION"(I.C.P) sh.p.k



"P.C.S COMPANY" sh.p.k



GRUPI I PROJEKTIMIT

Ing.Hidroteknik Evis QYRKU	Nr. Licence K.1829/2
Ing. Ndertimi Alban DAUTAJ	Nr. Licence K.2232/2
Ing. Ndertimi Pamela KURTULAJ(ALIU)	Nr. Licence K.1474/3
Arkitekt Endrit TUZI	Nr. Licence A.0128/6
Ing.Topograf Maksim GEGA	Nr. Licence T.0455/4
Ing.Gjeodet Albin KOCI	Nr. Licence E.1269/2
Ing.Elektrik Edmond PALODHI	Nr. Licence E.1552
Ing.Gjeolog Aslian BASHA	Nr. Licence GJ.0686
Ing.Mjedesi Shpetim CIKU	Nr. Licence A.2443
Ing.Hidroteknik Xhuljana DAUTAJ(SULA)	Nr. Licence K.2232/2
Arkitekt Jorida GRABOVARI	Nr. Licence A.2595

FIRMA/VULA

SHENIME

TE DHENA TEKNIKE

FAZA E PROJEKTIT	PROJEKT ZBATIM
TIPI I FLETES	
EMERTIMI I FLETES	PLANPIKETIMI 1:1000

Nr. i fletes **A-02**

PLANPIKETIMI I RRUGES SH 1: 1000

O B J E K T I

SISTEM-ASFALTIM I
RRUGES LAGJA RUSE -
JELLE, FSHATI HOMESH,
SHUPENZE,
BASHKIA BULQIZE

POROSITESI :
BASHKIA BULQIZE



PROJEKTUES :

"HYDRO-ENG CONSULTING"
sh.p.k



"IDEAL CONSTRUCTION
& PROJECTION"(I.C.P) sh.p.k



"P.C.S COMPANY" sh.p.k



GRUPI I PROJEKTIMIT

Ing.Hidroteknik Evis QYRKU	Nr. Licence K.1829/2
Ing. Ndertimi Alban DAUTAJ	Nr. Licence K.2232/2
Ing. Ndertimi Pamel KURTULAJ(ALIU)	Nr. Licence K.1474/3
Arkitekt Endrit TUZI	Nr. Licence A.0128/6
Ing.Topograf Maksim GEGA	Nr. Licence T.0455/4
Ing.Gjeodet Albin KOCI	Nr. Licence E.1269/2
Ing.Elektrik Edmond PALODHI	Nr. Licence E.1552
Ing.Gjeolog Asllan BASHA	Nr. Licence GJ.0686
Ing.Mjedisi Shpetim CIKU	Nr. Licence A.2443
Ing.Hidroteknik Xhuljana DAUTAJ(SULA)	Nr. Licence K.2232/2
Arkitekt Jorida GRABOVARI	Nr. Licence A.2595

FIRMA/VULA

SHENIME

TE DHENA TEKNIKE

FAZA E PROJEKTIT	PROJEKT ZBATIM
TIPI I FLETES	
EMERTIMI I FLETES	PLANPIKETIMI 1:1000

Nr. i fletes **A-03**

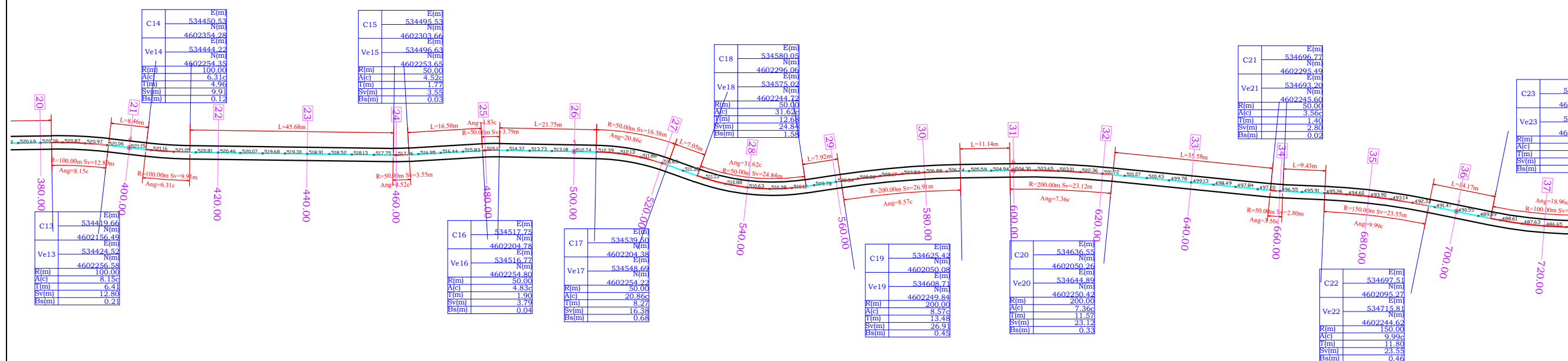

PLANPIKETIMI I RRUGES SH 1: 1000

O B J E K T I

SISTEM-ASFALTIM I
RRUGES LAGJA RUSE -
JELLE, FSHATI HOMESH,
SHUPENZE,
BASHKIA BULQIZE

POROSITESI :
BASHKIA BULQIZE



PROJEKTUES :

"HYDRO-ENG CONSULTING"
sh.p.k



"IDEAL CONSTRUCTION
& PROJECTION"(I.C.P) sh.p.k



"P.C.S COMPANY" sh.p.k



GRUPI I PROJEKTIMIT

Ing.Hidroteknik Evis QYRKU	Nr. Licence K.1829/2
Ing. Ndertimi Alban DAUTAJ	Nr. Licence K.2232/2
Ing. Ndertimi Pamelja KURTULAJ(ALIU)	Nr. Licence K.1474/3
Arkitekt Endrit TUZI	Nr. Licence A.0128/6
Ing.Topograf Maksim GEGA	Nr. Licence T.0455/4
Ing.Gjeodet Albin KOCI	Nr. Licence E.1269/2
Ing.Elektrik Edmond PALODHI	Nr. Licence E.1552
Ing.Gjeolog Asllan BASHA	Nr. Licence GJ.0686
Ing.Mjedisi Shpetim CIKU	Nr. Licence A.2443
Ing.Hidroteknik Xhujana DAUTAJ(SULA)	Nr. Licence K.2232/2
Arkitekt Jorida GRABOVARI	Nr. Licence A.2595

FIRMA/VULA

SHENIME

TE DHENA TEKNIKE

FAZA E PROJEKTIT	PROJEKT ZBATIM
TIPI I FLETES	
EMERTIMI I FLETES	PLANPIKETIMI 1:1000

Nr. i fletes **A-04**

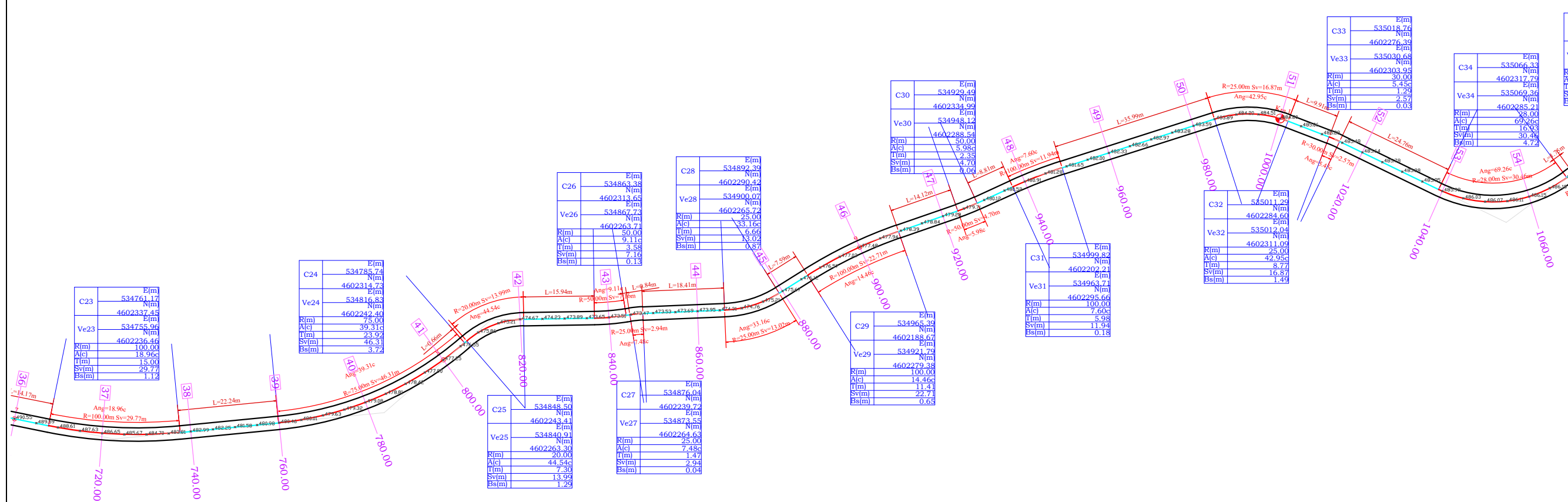

PLANPIKETIMI I RRUGES SH 1: 1000

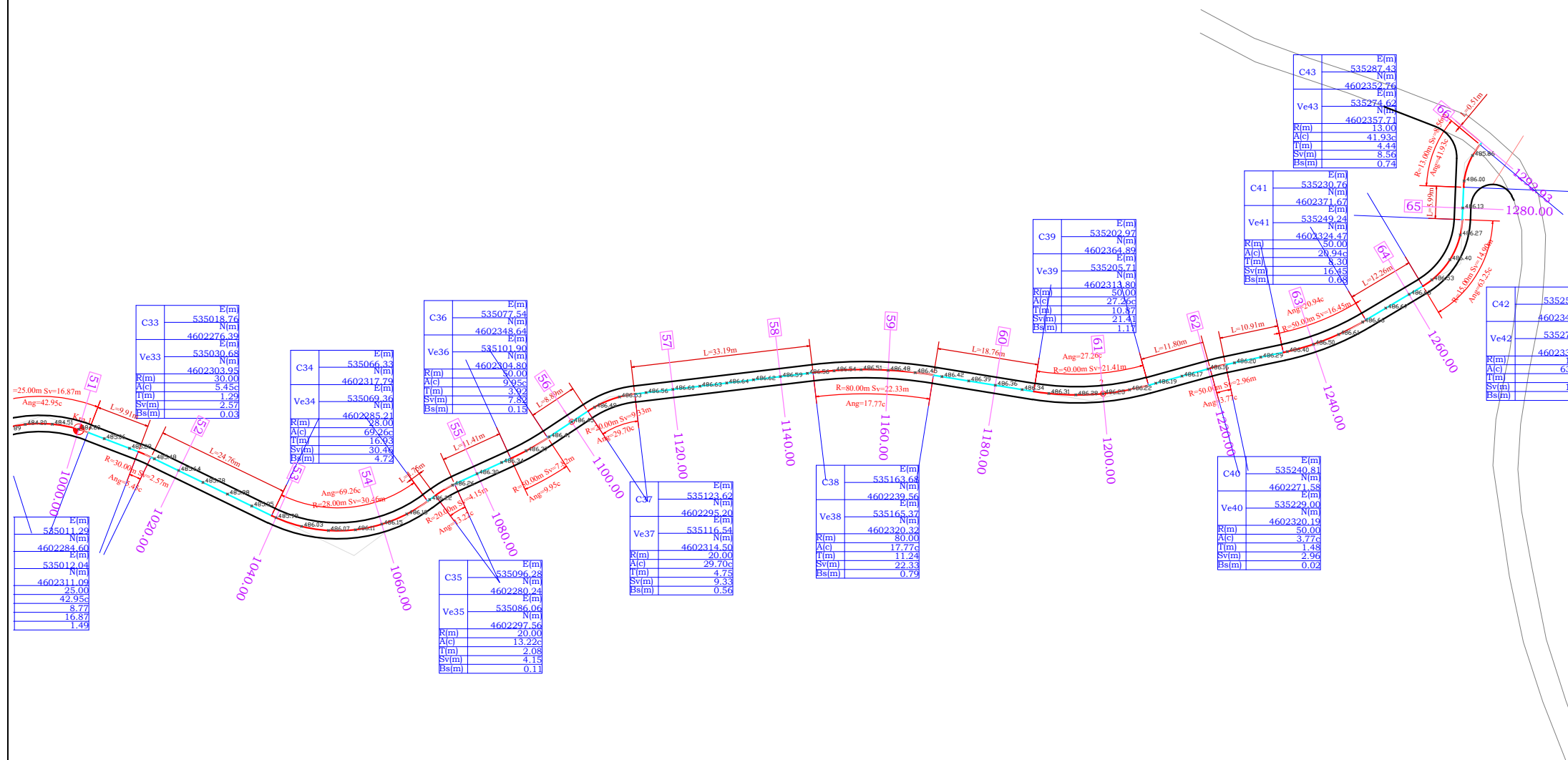

O B J E K T I

SISTEM-ASFALTIM I
RRUGES LAGJA RUSE -
JELLE, FSHATI HOMESH,
SHUPENZE,
BASHKIA BULQIZE

POROSITESI :
BASHKIA BULQIZE



PROJEKTUES :

"HYDRO-ENG CONSULTING "
sh.p.k



"IDEAL CONSTRUCTION
& PROJECTION"(I.C.P) sh.p.k



"P.C.S COMPANY " sh.p.k



GRUPI I PROJEKTIMIT

Ing.Hidroteknik Evis QYRKU	Nr. Licence K.1829/2
Ing. Ndertimi Alban DAUTAJ	Nr. Licence K.2232/2
Ing. Ndertimi Pamela KURTULAJ(ALIU)	Nr. Licence K.1474/3
Arkitekt Endrit TUZI	Nr. Licence A.0128/6
Ing.Topograf Maksim GEGA	Nr. Licence T.0455/4
Ing.Gjeodet Albin KOCI	Nr. Licence E.1269/2
Ing.Elektrik Edmond PALODHI	Nr. Licence E.1552
Ing.Gjeolog Asllan BASHA	Nr. Licence GJ.0686
Ing.Mjedisi Shpetim CIKU	Nr. Licence A.2443
Ing.Hidroteknik Xhujana DAUTAJ(SULA)	Nr. Licence K.2232/2
Arkitekt Jorida GRABOVARI	Nr. Licence A.2595

FIRMA/VULA

SHENIME

TE DHENA TEKNIKE

FAZA E PROJEKTIT	PROJEKT ZBATIM
TIPI I FLETES	
EMERTIMI I FLETES	PLANPIKETIMI 1:1000

Nr. i fletes **A-05**

SISTEM-ASFALTIM I
RRUGES LAGJA RUSE -
JELLE, FSHATI HOMESH,
SHUPENZE,
BASHKIA BULQIZE

POROSITESI :
BASHKIA BULQIZE



PROJEKTUES :

"HYDRO-ENG CONSULTING"
sh.p.k



"IDEAL CONSTRUCTION
& PROJECTION"(I.C.P) sh.p.k



"P.C.S COMPANY" sh.p.k



GRUPI I PROJEKTIMIT

Ing.Hidroteknik Evis QYRKU	Nr. Licence K.1829/2
Ing. Ndertimi Alban DAUTAJ	Nr. Licence K.2232/2
Ing. Ndertimi Pamela KURTULAJ(ALIU)	Nr. Licence K.1474/3
Arkitekt Endrit TUZI	Nr. Licence A.0128/6
Ing.Topograf Maksim GEGA	Nr. Licence T.0455/4
Ing.Gjeodet Albin KOCI	Nr. Licence E.1269/2
Ing.Elektrik Edmond PALODHI	Nr. Licence E.1552
Ing.Gjeolog Asllan BASHA	Nr. Licence GJ.0686
Ing.Mjedisi Shpetim CIKU	Nr. Licence A.2443
Ing.Hidroteknik Xhuljana DAUTA(SULA)	Nr. Licence K.2232/2
Arkitekt Jorida GRABOVARI	Nr. Licence A.2595

FIRMA/VULA

SHENIME

TE DHENA TEKNIKE

FAZA E PROJEKTIT PROJEKT ZBATIM

TIPI I FLETES

EMERTIMI I FLETES PROFILE TERTHOR
SH 1:200

Nr. i fletes **A-06**

GERMIME	3.10 m ²
GERMINI	3.10 m ²
MBUSHJE	2.68 m ²
Mbushje Frascje	2.68 m ²
MBISTRUKTURA RRUGORE	
Shtrese Asfaltobetoni	8.93 m
Shtrese Hinderi	8.93 m
Shtrese Stabilizanti	9.14 m
Shtrese Çakelli	9.42 m
BANKINE	1.00 m

Nr. Profili : 1
Kuot. Projekti : 526.86
Dist.Progr. : 0.00
Dist.Pas. : 20.00

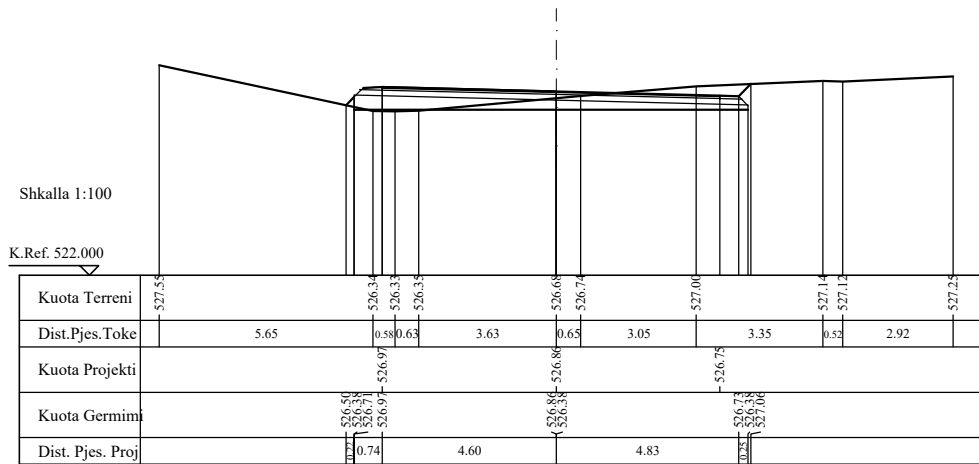

GERMIME	3.10 m ²
GERMINI	3.10 m ²
MBUSHJE	0.89 m ²
Mbushje Frascje	0.89 m ²
MBISTRUKTURA RRUGORE	
Shtrese Asfaltobetoni	3.99 m
Shtrese Hinderi	3.99 m
Shtrese Stabilizanti	3.19 m
Shtrese Çakelli	3.48 m
BANKINE	1.00 m

Nr. Profili : 3
Kuot. Projekti : 528.92
Dist.Progr. : 40.00
Dist.Pas. : 20.00

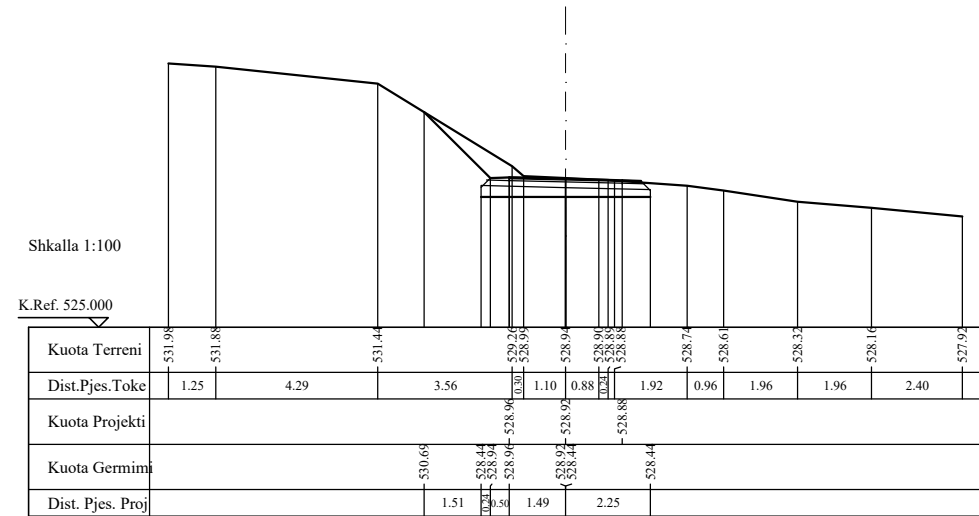

GERMIME	2.58 m ²
GERMINI	2.58 m ²
MBUSHJE	0.90 m ²
Mbushje Frascje	0.90 m ²
MBISTRUKTURA RRUGORE	
Shtrese Asfaltobetoni	3.00 m
Shtrese Hinderi	3.00 m
Shtrese Stabilizanti	3.20 m
Shtrese Çakelli	3.49 m
BANKINE	1.00 m

Nr. Profili : 2
Kuot. Projekti : 528.56
Dist.Progr. : 20.00
Dist.Pas. : 20.00

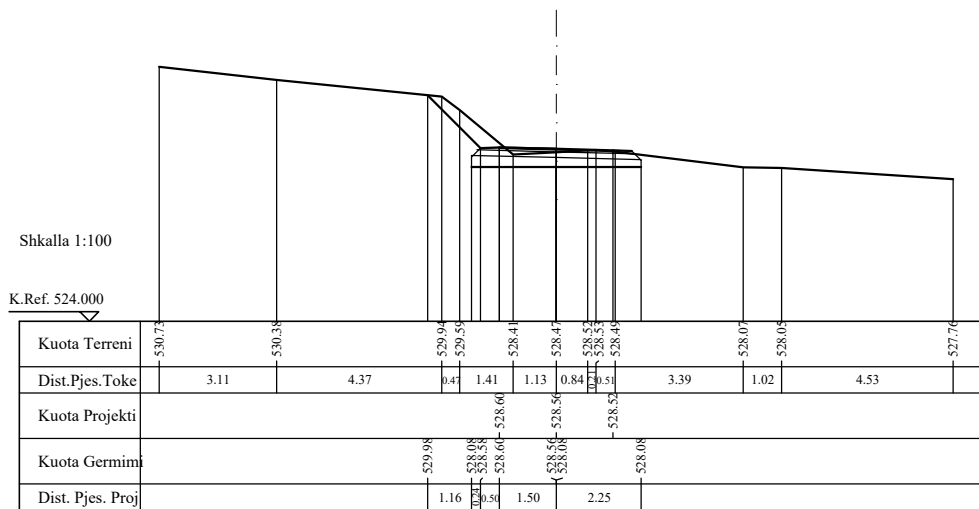

GERMIME	2.22 m ²
GERMINI	2.22 m ²
MBUSHJE	0.90 m ²
Mbushje Frascje	0.90 m ²
MBISTRUKTURA RRUGORE	
Shtrese Asfaltobetoni	3.00 m
Shtrese Hinderi	3.00 m
Shtrese Stabilizanti	3.20 m
Shtrese Çakelli	3.49 m
BANKINE	1.00 m

Nr. Profili : 4
Kuot. Projekti : 527.82
Dist.Progr. : 60.00
Dist.Pas. : 20.00

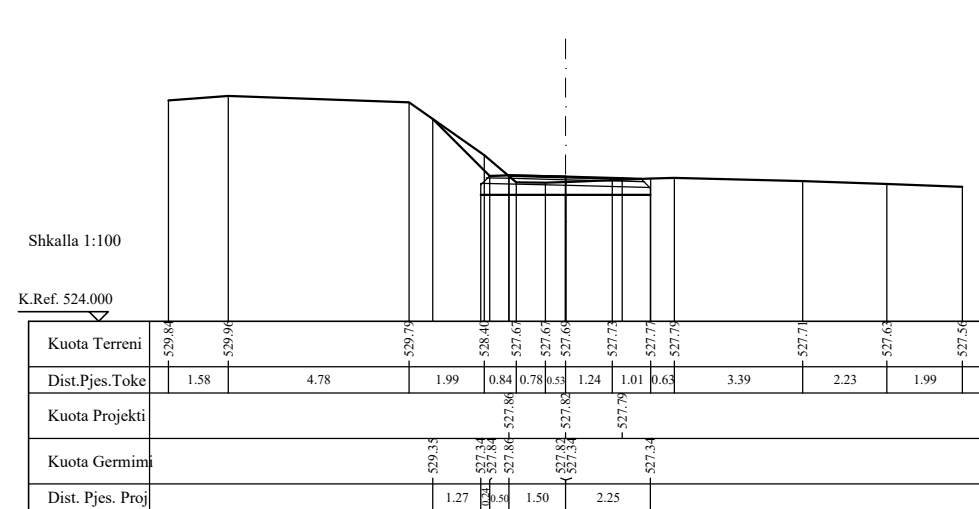

SISTEM-ASFALTIM I
RRUGES LAGJA RUSE -
JELLE, FSHATI HOMESH,
SHUPENZE,
BASHKIA BULQIZE

POROSITESI :
BASHKIA BULQIZE



PROJEKTUES :

"HYDRO-ENG CONSULTING"
sh.p.k



"IDEAL CONSTRUCTION
& PROJECTION"(I.C.P) sh.p.k



"P.C.S COMPANY" sh.p.k



GRUPI I PROJEKTIMIT

Ing.Hidroteknik Evis QYRKU	Nr. Licence K.1829/2
Ing. Ndertimi Alban DAUTAJ	Nr. Licence K.2232/2
Ing. Ndertimi Pamela KURTULAJ(ALIU)	Nr. Licence K.1474/3
Arkitekt Endrit TUZI	Nr. Licence A.0128/6
Ing.Topograf Maksim GEGA	Nr. Licence T.0455/4
Ing.Gjeodet Albin KOCI	Nr. Licence E.1269/2
Ing.Elektrik Edmond PALODHI	Nr. Licence E.1552
Ing.Gjeolog Asllan BASHA	Nr. Licence GJ.0686
Ing.Mjedisi Shpetim CIKU	Nr. Licence A.2443
Ing.Hidroteknik Xhuljana DAUTA(SULA)	Nr. Licence K.2232/2
Arkitekt Jorida GRABOVARI	Nr. Licence A.2595

FIRMA/VULA

SHENIME

TE DHENA TEKNIKE

FAZA E PROJEKTIT	PROJEKT ZBATIM
TIPI I FLETES	
EMERTIMI I FLETES	PROFILE TERTHOR SH 1:200

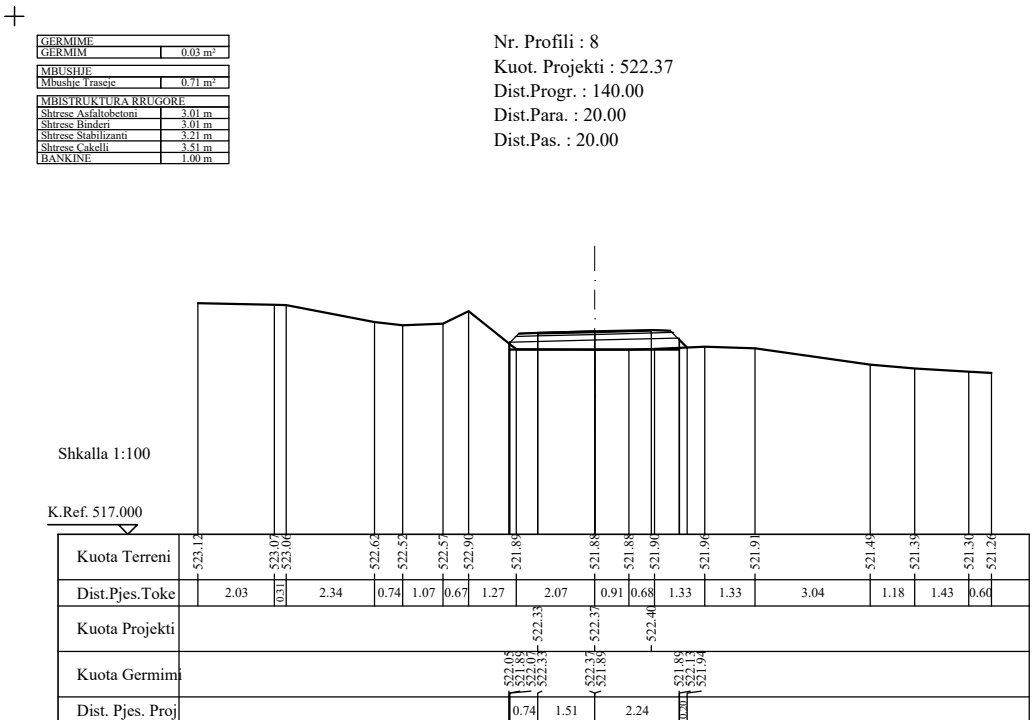
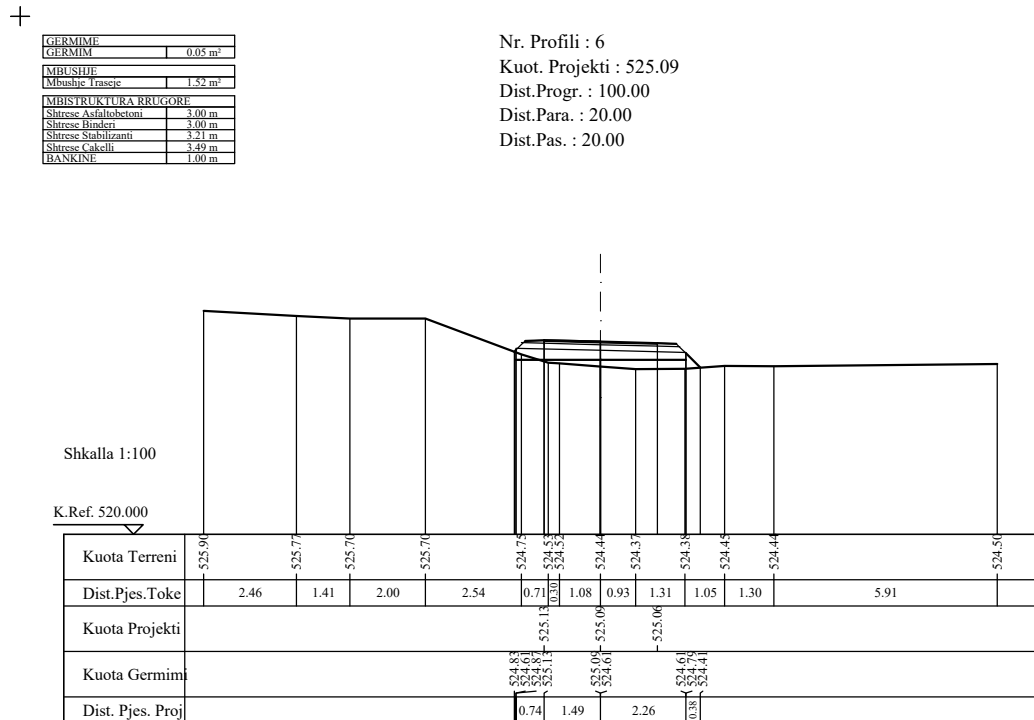
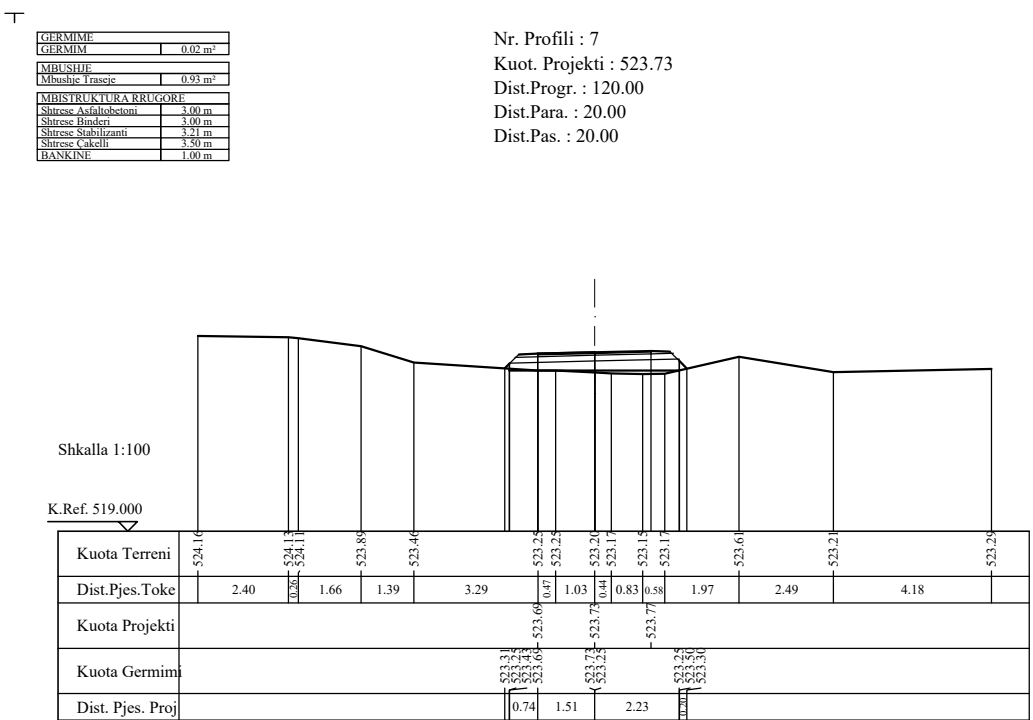
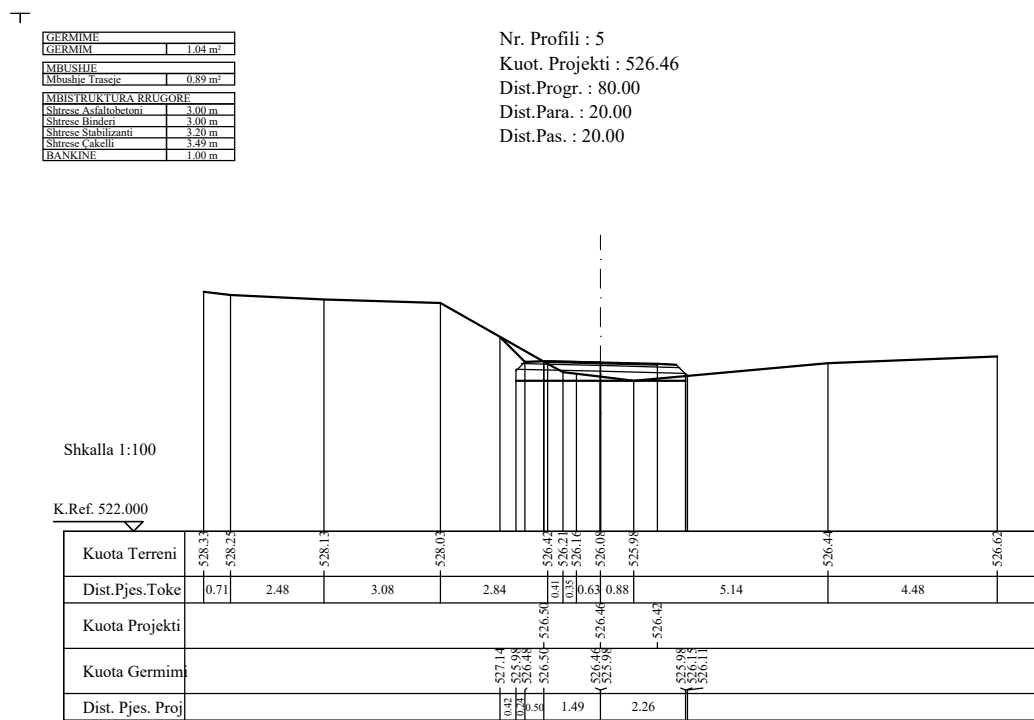

SISTEM-ASFALTIM I
RRUGES LAGJA RUSE -
JELLE, FSHATI HOMESH,
SHUPENZE,
BASHKIA BULQIZE

POROSITESI :
BASHKIA BULQIZE



PROJEKTUES :

"HYDRO-ENG CONSULTING"
sh.p.k



"IDEAL CONSTRUCTION
& PROJECTION"(I.C.P) sh.p.k



"P.C.S COMPANY" sh.p.k



GRUPI I PROJEKTIMIT

Ing.Hidroteknik Evis QYRKU	Nr. Licence K.1829/2
Ing. Ndertimi Alban DAUTAJ	Nr. Licence K.2232/2
Ing. Ndertimi Pamela KURTULAJ(ALIU)	Nr. Licence K.1474/3
Arkitekt Endrit TUZI	Nr. Licence A.0128/6
Ing.Topograf Maksim GEGA	Nr. Licence T.0455/4
Ing.Gjeodet Albin KOCI	Nr. Licence E.1269/2
Ing.Elektrik Edmond PALODHI	Nr. Licence E.1552
Ing.Gjeolog Asllan BASHA	Nr. Licence GJ.0686
Ing.Mjedisi Shpetim CIKU	Nr. Licence A.2443
Ing.Hidroteknik Xhuljana DAUTA(SULA)	Nr. Licence K.2232/2
Arkitekt Jorida GRABOVARI	Nr. Licence A.2595

FIRMA/VULA

SHENIME

TE DHENA TEKNIKE

FAZA E PROJEKTIT PROJEKT ZBATIM

TIPI I FLETES

EMERTIMI I FLETES PROFILE TERTHOR
SH 1:200

Nr. i fletes **A-08**

GERMIME	2.96 m ²
GERMIMI	
MBUSHJE	0.95 m ²
Mbushje Traseje	
MBISTRUKTURA RRUGORE	
Shtrese Asfaltbetoni	3.00 m
Shtrese Bindje	3.00 m
Shtrese Stabilizanti	3.20 m
Shtrese Çakelli	3.49 m
BANKINE	1.00 m

Nr. Profili : 9
Kuot. Projekti : 521.00
Dist.Progr. : 160.00
Dist.Para. : 20.00
Dist.Pas. : 20.00

GERMIME	2.00 m ²
GERMIMI	
MBUSHJE	0.85 m ²
Mbushje Traseje	
MBISTRUKTURA RRUGORE	
Shtrese Asfaltbetoni	2.99 m
Shtrese Bindje	2.99 m
Shtrese Stabilizanti	3.19 m
Shtrese Çakelli	3.48 m
BANKINE	1.00 m

Nr. Profili : 11
Kuot. Projekti : 519.46
Dist.Progr. : 200.00
Dist.Para. : 20.00
Dist.Pas. : 20.00

Shkalla 1:100

K.Ref. 516.000

Kuota Terreni	-522.46	-522.16	-522.05	-521.77	-520.96	-521.11	-521.44	-520.76	-520.22
Dist.Pjes.Toke	2.78	0.88	0.58	5.19	1.08	1.13	4.18	4.88	0.81
Kuota Projekti									
Kuota Germimi									
Dist. Pjes. Proj				1.50	1.50	2.00	0.81		

Shkalla 1:100

K.Ref. 515.000

Kuota Terreni	-520.97	-520.81	-520.75	-519.86	-519.55	-519.54	-519.22	-519.02	-519.11	-518.55	-518.31
Dist.Pjes.Toke	2.32	1.18	5.12	0.67	0.79	0.81	1.56	1.24	4.87	2.01	
Kuota Projekti											
Kuota Germimi											
Dist. Pjes. Proj				0.30	0.30	1.50	2.23				

GERMIME	1.60 m ²
GERMIMI	
MBUSHJE	0.79 m ²
Mbushje Traseje	
MBISTRUKTURA RRUGORE	
Shtrese Asfaltbetoni	3.00 m
Shtrese Bindje	3.00 m
Shtrese Stabilizanti	3.20 m
Shtrese Çakelli	3.49 m
BANKINE	1.00 m

Nr. Profili : 10
Kuot. Projekti : 519.85
Dist.Progr. : 180.00
Dist.Para. : 20.00
Dist.Pas. : 20.00

GERMIME	0.15 m ²
GERMIMI	
MBUSHJE	1.72 m ²
Mbushje Traseje	
MBISTRUKTURA RRUGORE	
Shtrese Asfaltbetoni	3.00 m
Shtrese Bindje	3.00 m
Shtrese Stabilizanti	3.20 m
Shtrese Çakelli	3.49 m
BANKINE	1.00 m

Nr. Profili : 12
Kuot. Projekti : 519.88
Dist.Progr. : 220.00
Dist.Para. : 20.00
Dist.Pas. : 20.00

Shkalla 1:100

K.Ref. 515.000

Kuota Terreni	-521.51	-521.5	-521.41	-521.5	-519.76	-519.66	-519.77	-519.7	-519.21
Dist.Pjes.Toke	0.78	1.10	2.89	4.05	1.48	0.75	4.13	5.32	0.81
Kuota Projekti									
Kuota Germimi									
Dist. Pjes. Proj				0.50	1.50	2.25			

Shkalla 1:100

K.Ref. 515.000

Kuota Terreni	-522.27	-521.81	-521.71	-519.31	-519.22	-519.22	-519.11	-519.01	-518.81	-518.51
Dist.Pjes.Toke	3.81	0.54	4.67	1.39	0.89	0.48	1.37	7.44		
Kuota Projekti										
Kuota Germimi										
Dist. Pjes. Proj				0.74	1.50	2.25	0.75			

SISTEM-ASFALTIM I
RRUGES LAGJA RUSE -
JELLE, FSHATI HOMESH,
SHUPENZE,
BASHKIA BULQIZE

POROSITESI :
BASHKIA BULQIZE



PROJEKTUES :

"HYDRO-ENG CONSULTING"
sh.p.k



"IDEAL CONSTRUCTION
& PROJECTION"(I.C.P) sh.p.k



"P.C.S COMPANY" sh.p.k



GRUPI I PROJEKTIMIT

Ing.Hidroteknik Evis QYRKU	Nr. Licence K.1829/2
Ing. Ndertimi Alban DAUTAJ	Nr. Licence K.2232/2
Ing. Ndertimi Pamela KURTULAJ(ALIU)	Nr. Licence K.1474/3
Arkitekt Endrit TUZI	Nr. Licence A.0128/6
Ing.Topograf Maksim GEGA	Nr. Licence T.0455/4
Ing.Gjeodet Albin KOCI	Nr. Licence E.1269/2
Ing.Elektrik Edmond PALODHI	Nr. Licence E.1552
Ing.Gjeolog Asllan BASHA	Nr. Licence GJ.0686
Ing.Mjedisi Shpetim CIKU	Nr. Licence A.2443
Ing.Hidroteknik Xhuljana DAUTA(SULA)	Nr. Licence K.2232/2
Arkitekt Jorida GRABOVARI	Nr. Licence A.2595

FIRMA/VULA

SHENIME

TE DHENA TEKNIKE

FAZA E PROJEKTIT PROJEKT ZBATIM

TIPI I FLETES

EMERTIMI I FLETES PROFILE TERTHOR
SH 1:200

Nr. i fletes **A-10**

GERMIME	1.38 m ²
GERMIM	
MBUSHJE	
Mbushje Traese	0.74 m ²
MBISTRUKTURA RRUGORE	
Shirese Asfaltobeton	3.00 m
Shirese Banderi	3.00 m
Shirese Stabilizanti	3.20 m
Shirese Cakelli	3.49 m
BANKINE	1.00 m

Nr. Profili : 17
Kuot. Projekti : 522.64
Dist.Progr. : 320.00
Dist.Para. : 20.00
Dist.Pas. : 20.00

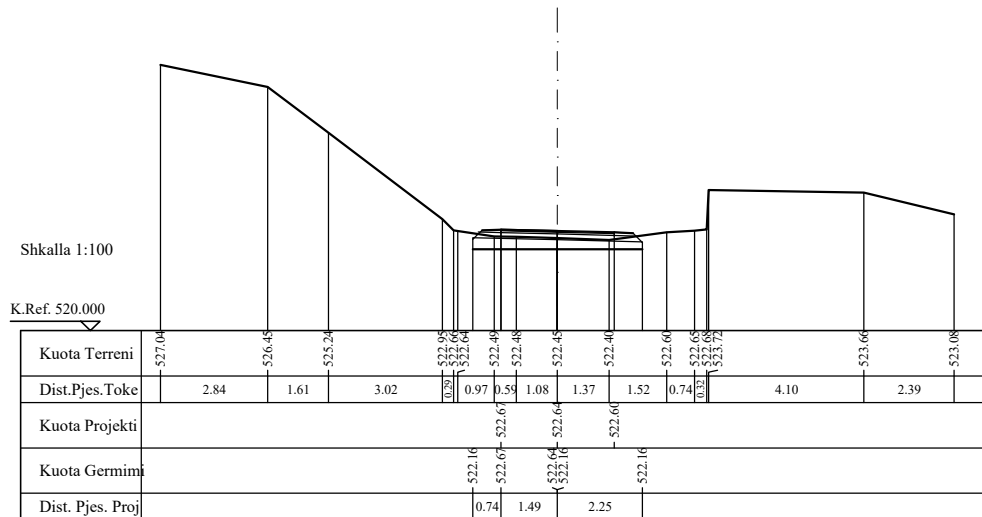

GERMIME	1.48 m ²
GERMIM	
MBUSHJE	
Mbushje Traese	0.79 m ²
MBISTRUKTURA RRUGORE	
Shirese Asfaltobeton	3.00 m
Shirese Banderi	3.00 m
Shirese Stabilizanti	3.20 m
Shirese Cakelli	3.49 m
BANKINE	1.00 m

Nr. Profili : 19
Kuot. Projekti : 520.52
Dist.Progr. : 360.00
Dist.Para. : 20.00
Dist.Pas. : 20.00

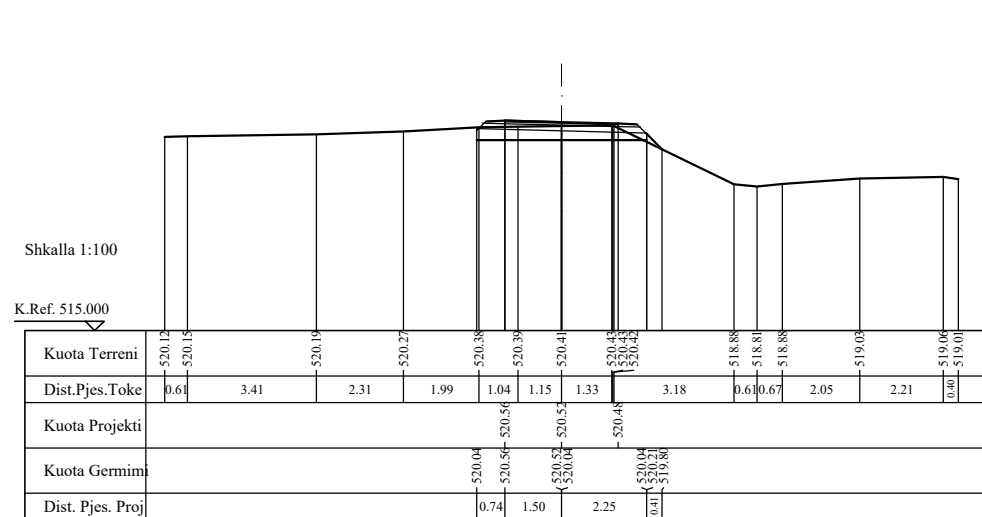

GERMIME	1.12 m ²
GERMIM	
MBUSHJE	
Mbushje Traese	0.72 m ²
MBISTRUKTURA RRUGORE	
Shirese Asfaltobeton	3.00 m
Shirese Banderi	3.00 m
Shirese Stabilizanti	3.20 m
Shirese Cakelli	3.49 m
BANKINE	1.00 m

Nr. Profili : 18
Kuot. Projekti : 521.10
Dist.Progr. : 340.00
Dist.Para. : 20.00
Dist.Pas. : 20.00

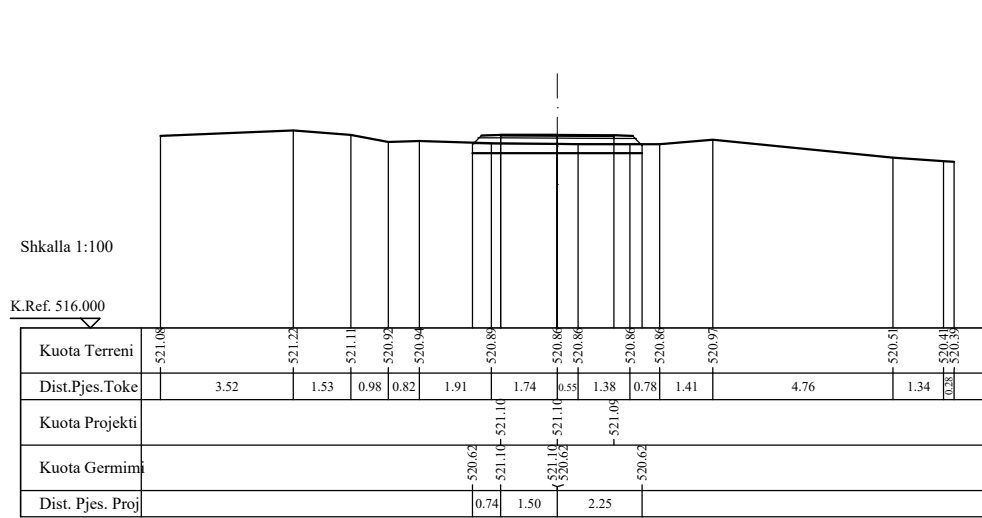

GERMIME	0.54 m ²
GERMIM	
MBUSHJE	
Mbushje Traese	1.03 m ²
MBISTRUKTURA RRUGORE	
Shirese Asfaltobeton	3.00 m
Shirese Banderi	3.00 m
Shirese Stabilizanti	3.20 m
Shirese Cakelli	3.49 m
BANKINE	1.00 m

Nr. Profili : 20
Kuot. Projekti : 520.78
Dist.Progr. : 380.00
Dist.Para. : 20.00
Dist.Pas. : 20.00

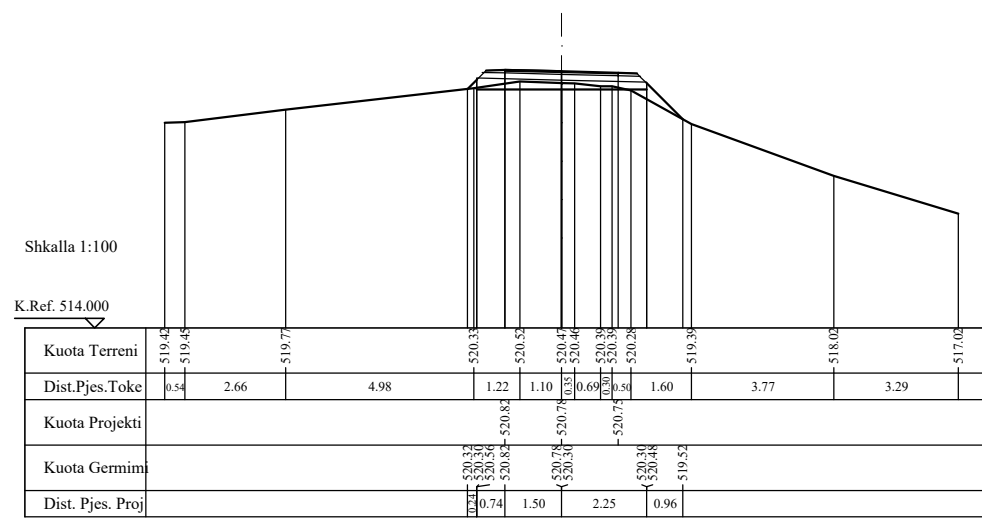

PROFILE TERTHOR SH 1:200

O B J E K T I

SISTEM-ASFALTIM I
RRUGES LAGJA RUSE -
JELLE, FSHATI HOMESH,
SHUPENZE,
BASHKIA BULQIZE

POROSITESI :
BASHKIA BULQIZE



PROJEKTUES :

"HYDRO-ENG CONSULTING"
sh.p.k



"IDEAL CONSTRUCTION
& PROJECTION"(I.C.P) sh.p.k



"P.C.S COMPANY" sh.p.k



GRUPI I PROJEKTIMIT

Ing.Hidroteknik Evis QYRKU	Nr. Licence K.1829/2
Ing. Ndertimi Alban DAUTAJ	Nr. Licence K.2232/2
Ing. Ndertimi Pamela KURTULAJ(ALIU)	Nr. Licence K.1474/3
Arkitekt Endrit TUZI	Nr. Licence A.0128/6
Ing.Topograf Maksim GEGA	Nr. Licence T.0455/4
Ing.Gjeodet Albin KOCI	Nr. Licence E.1269/2
Ing.Elektrik Edmond PALODHI	Nr. Licence E.1552
Ing.Gjeolog Asllan BASHA	Nr. Licence GJ.0686
Ing.Mjedisi Shpetim CIKU	Nr. Licence A.2443
Ing.Hidroteknik Xhuljana DAUTAJ(SULA)	Nr. Licence K.2232/2
Arkitekt Jorida GRABOVARI	Nr. Licence A.2595

FIRMA/VULA

SHENIME

TE DHENA TEKNIKE

FAZA E PROJEKTIT PROJEKT ZBATIM

TIPI I FLETES

EMERTIMI I FLETES PROFILE TERTHOR
SH 1:200

Nr. i fletes **A-11**

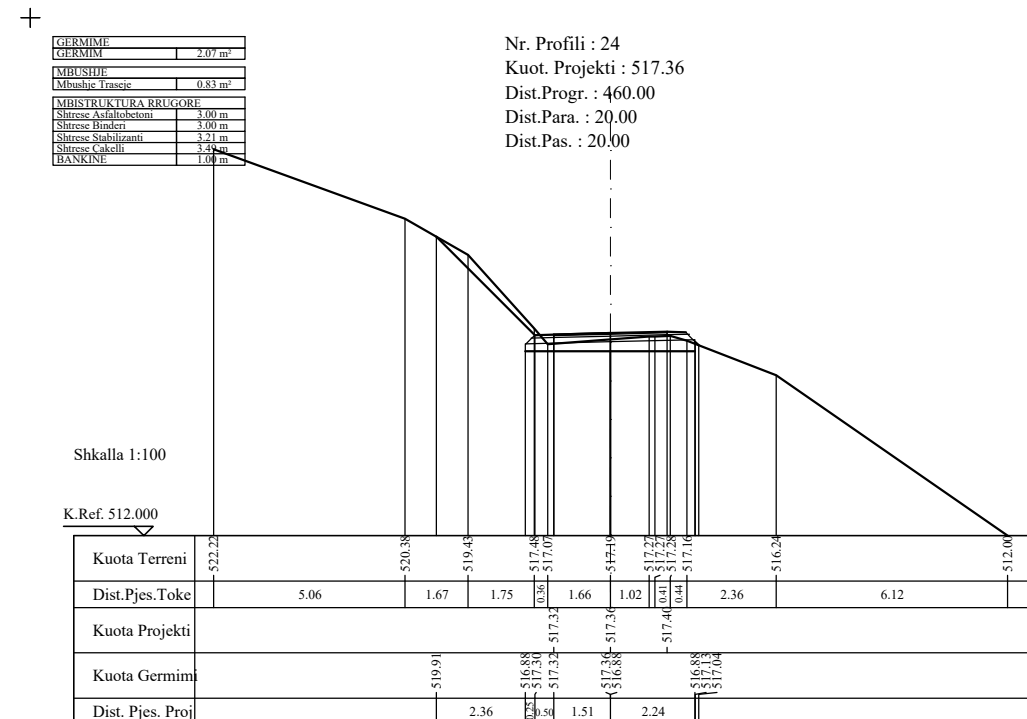
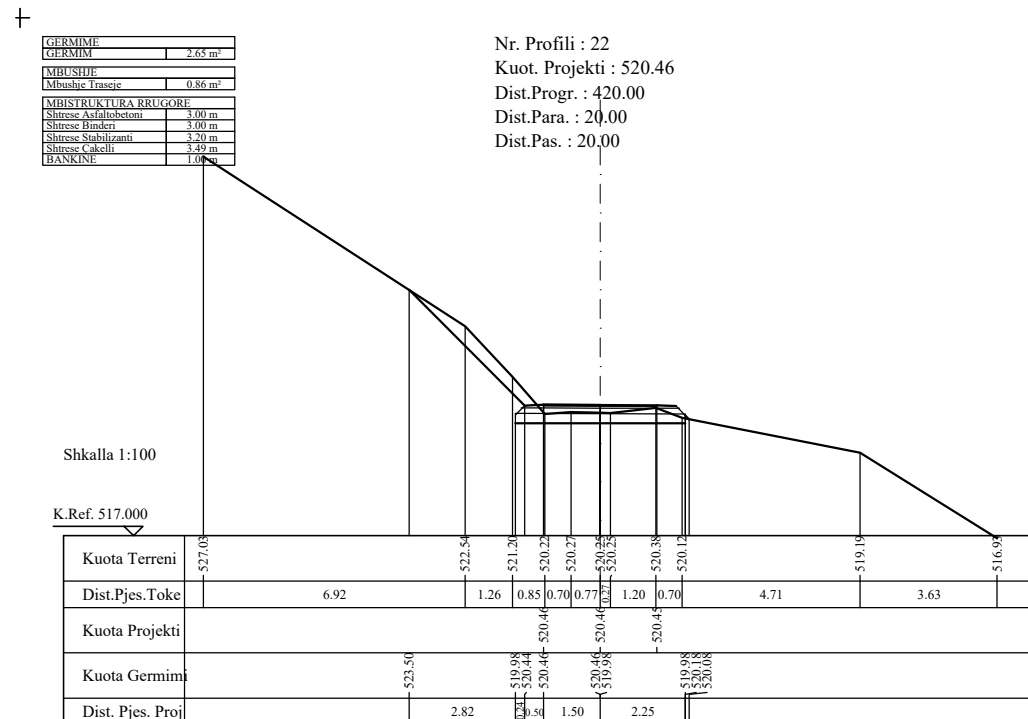
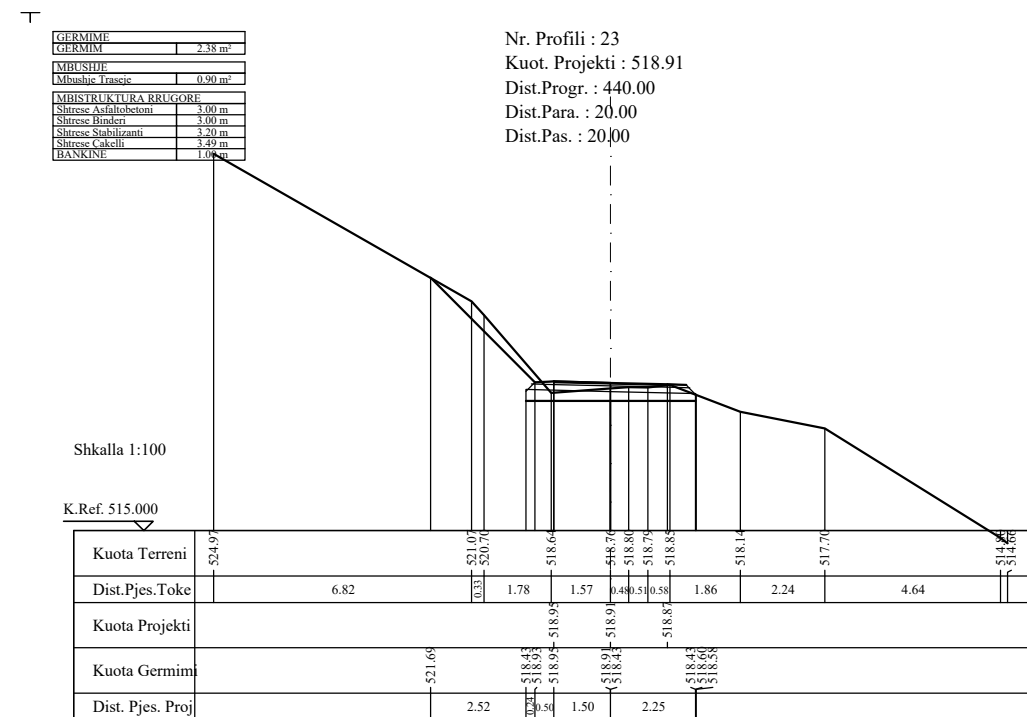
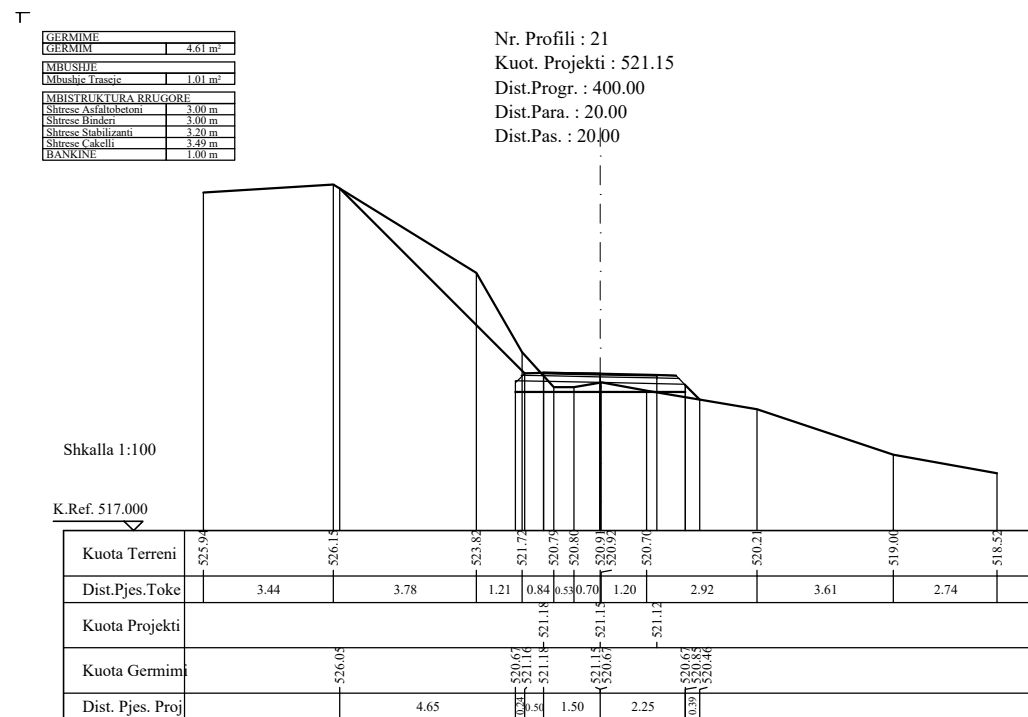

SISTEM-ASFALTIM I
RRUGES LAGJA RUSE -
JELLE, FSHATI HOMESH,
SHUPENZE,
BASHKIA BULQIZE

POROSITESI :
BASHKIA BULQIZE



PROJEKTUES :

"HYDRO-ENG CONSULTING"
sh.p.k



"IDEAL CONSTRUCTION
& PROJECTION"(I.C.P) sh.p.k



"P.C.S COMPANY" sh.p.k



GRUPI I PROJEKTIMIT

Ing.Hidroteknik Evis QYRKU	Nr. Licence K.1829/2
Ing. Ndertimi Alban DAUTAJ	Nr. Licence K.2232/2
Ing. Ndertimi Pamela KURTULAJ(ALIU)	Nr. Licence K.1474/3
Arkitekt Endrit TUZI	Nr. Licence A.0128/6
Ing.Topograf Maksim GEGA	Nr. Licence T.0455/4
Ing.Gjeodet Albin KOCI	Nr. Licence E.1269/2
Ing.Elektrik Edmond PALODHI	Nr. Licence E.1552
Ing.Gjeolog Asllan BASHA	Nr. Licence GJ.0686
Ing.Mjedisi Shpetim CIKU	Nr. Licence A.2443
Ing.Hidroteknik Xhuljana DAUTAJ(SULA)	Nr. Licence K.2232/2
Arkitekt Jorida GRABOVARI	Nr. Licence A.2595

FIRMA/VULA

SHENIME

TE DHENA TEKNIKE

FAZA E PROJEKTIT PROJEKT ZBATIM

TIPI I FLETES

EMERTIMI I FLETES PROFILE TERTHOR
SH 1:200

Nr. i fletes **A-12**

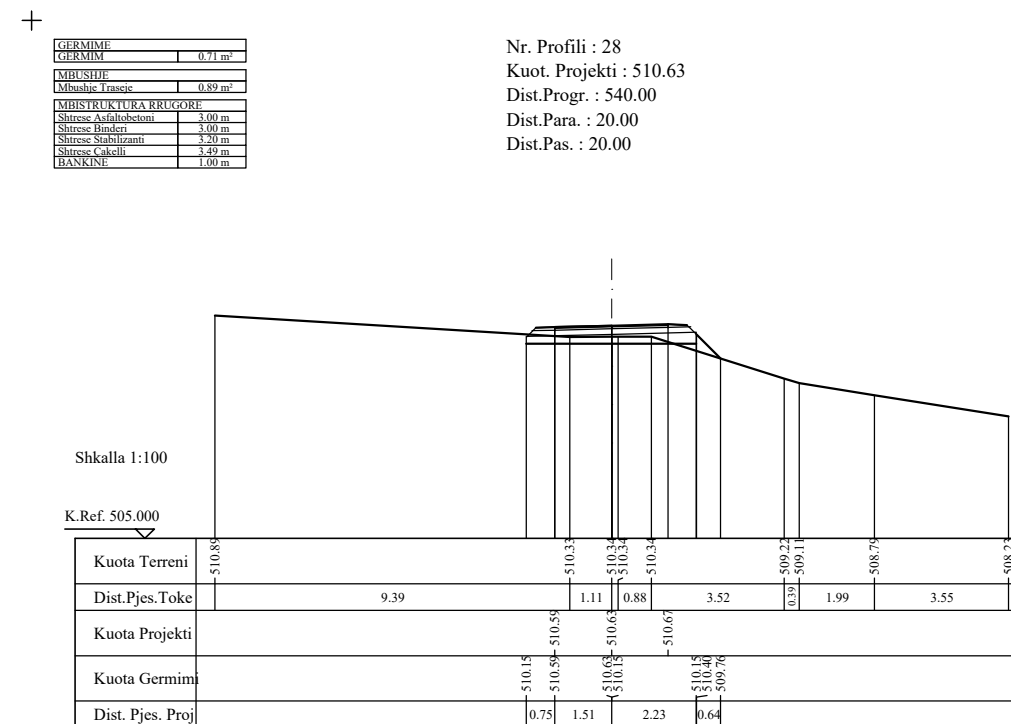
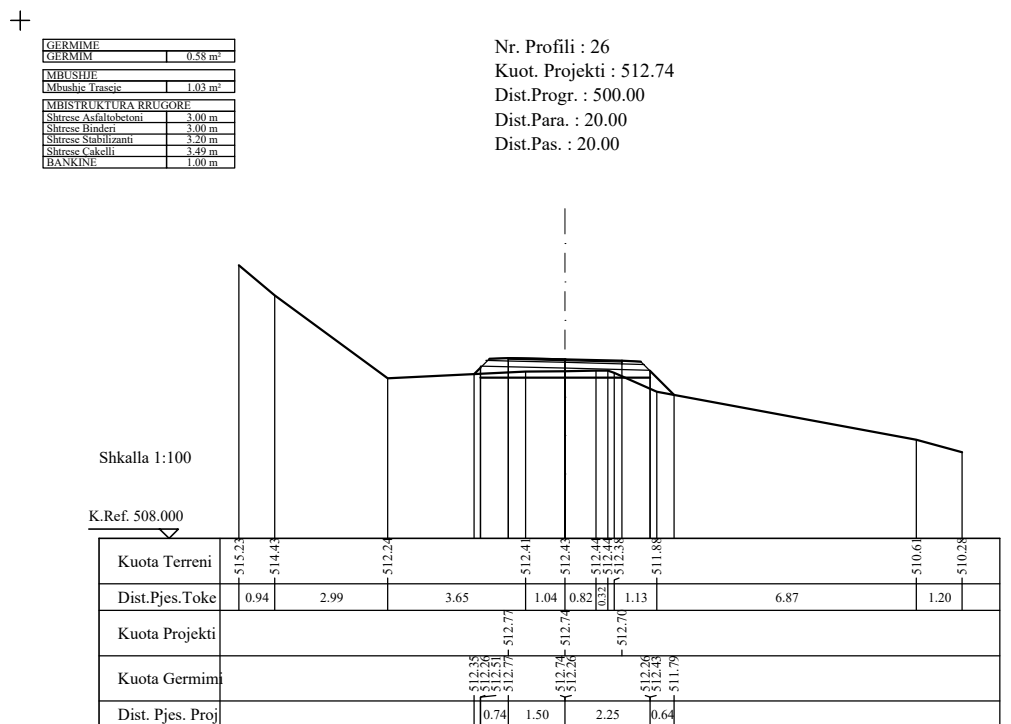
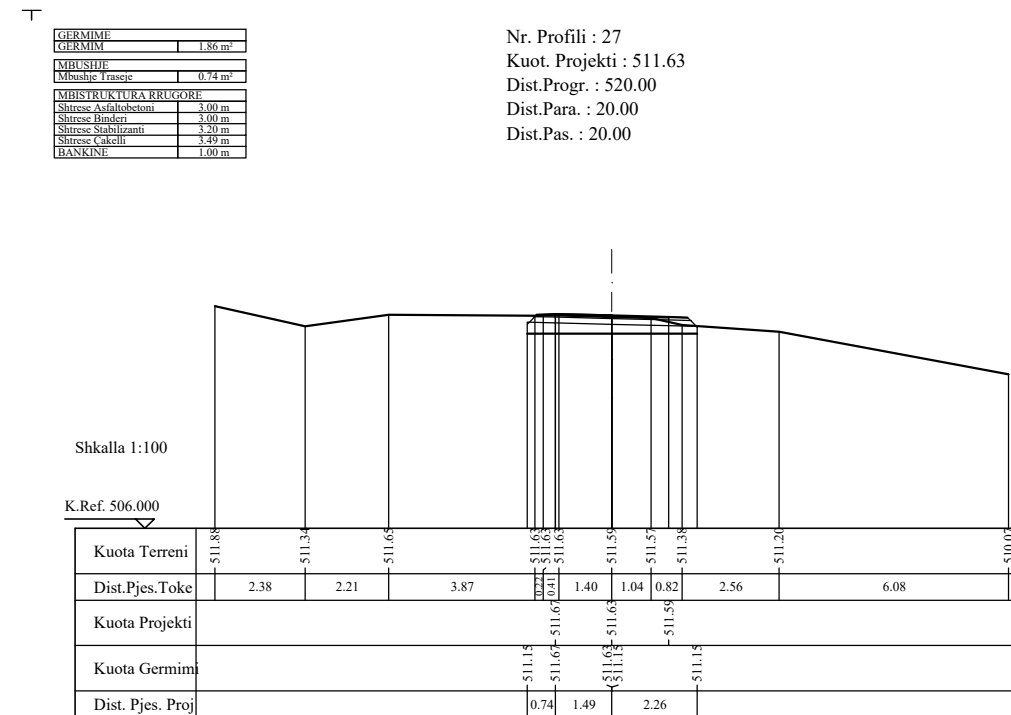
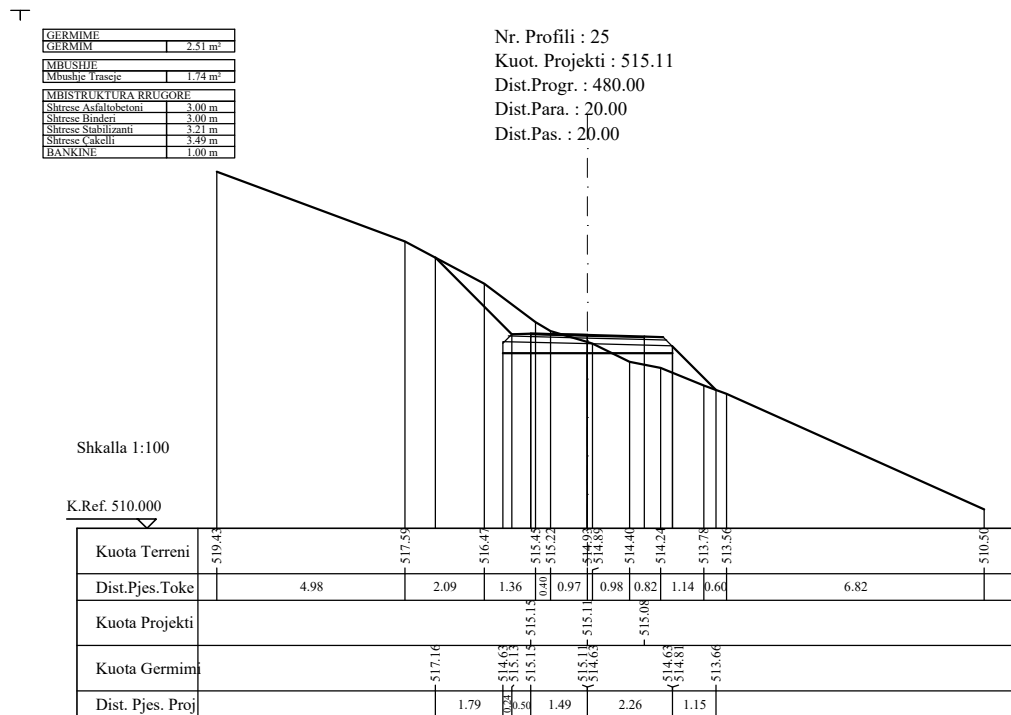

SISTEM-ASFALTIM I
RRUGES LAGJA RUSE -
JELLE, FSHATI HOMESH,
SHUPENZE,
BASHKIA BULQIZE

POROSITESI :
BASHKIA BULQIZE



PROJEKTUES :

"HYDRO-ENG CONSULTING"
sh.p.k



"IDEAL CONSTRUCTION
& PROJECTION"(I.C.P) sh.p.k



"P.C.S COMPANY" sh.p.k



GRUPI I PROJEKTIMIT

Ing.Hidroteknik Evis QYRKU	Nr. Licence K.1829/2
Ing. Ndertimi Alban DAUTAJ	Nr. Licence K.2232/2
Ing. Ndertimi Pamela KURTULAJ(ALIU)	Nr. Licence K.1474/3
Arkitekt Endrit TUZI	Nr. Licence A.0128/6
Ing.Topograf Maksim GEGA	Nr. Licence T.0455/4
Ing.Gjeodet Albin KOCI	Nr. Licence E.1269/2
Ing.Elektrik Edmond PALODHI	Nr. Licence E.1552
Ing.Gjeolog Asllan BASHA	Nr. Licence GJ.0686
Ing.Mjedisi Shpetim CIKU	Nr. Licence A.2443
Ing.Hidroteknik Xhuljana DAUTA(J SULA)	Nr. Licence K.2232/2
Arkitekt Jorida GRABOVARI	Nr. Licence A.2595

FIRMA/VULA

SHENIME

TE DHENA TEKNIKE

FAZA E PROJEKTIT PROJEKT ZBATIM

TIPI I FLETES

EMERTIMI I FLETES PROFILE TERTHOR
SH 1:200

Nr. i fletes **A-13**

GERMIME	1.11 m ²
MBUSHJE	0.76 m ²
MBISTRUKTURA RRUGORE	
Shiresë Asfalobeton	3.00 m
Shiresë Banderi	3.00 m
Shiresë Stabilizanti	3.20 m
Shiresë Çakelli	3.49 m
BANKINE	1.00 m

Nr. Profili : 29
Kuot. Projekti : 509.34
Dist.Progr. : 560.00
Dist.Para. : 20.00
Dist.Pas. : 20.00

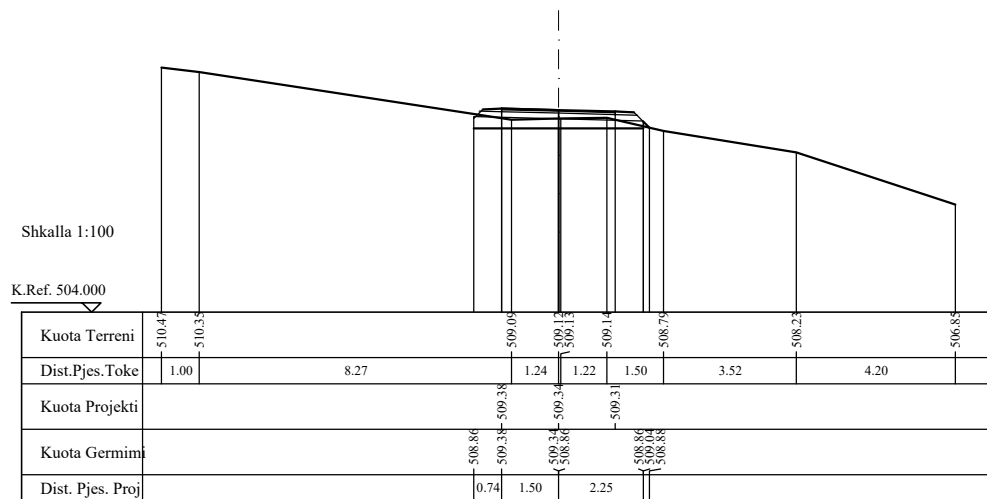

GERMIME	0.62 m ²
MBUSHJE	2.76 m ²
MBISTRUKTURA RRUGORE	
Shiresë Asfalobeton	3.00 m
Shiresë Banderi	3.00 m
Shiresë Stabilizanti	3.20 m
Shiresë Çakelli	3.49 m
BANKINE	1.00 m

Nr. Profili : 31
Kuot. Projekti : 504.30
Dist.Progr. : 600.00
Dist.Para. : 20.00
Dist.Pas. : 20.00

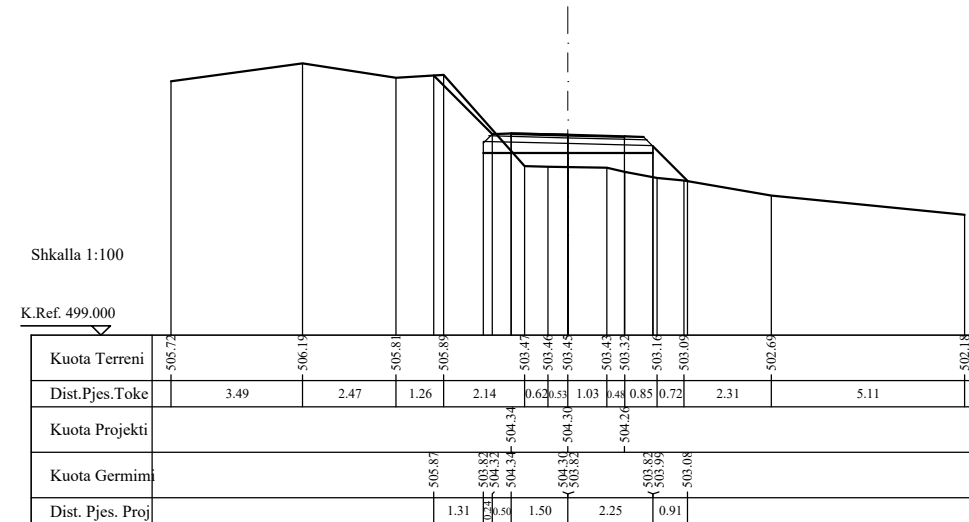

GERMIME	0.18 m ²
MBUSHJE	0.94 m ²
MBISTRUKTURA RRUGORE	
Shiresë Asfalobeton	3.00 m
Shiresë Banderi	3.00 m
Shiresë Stabilizanti	3.20 m
Shiresë Çakelli	3.49 m
BANKINE	1.00 m

Nr. Profili : 30
Kuot. Projekti : 506.88
Dist.Progr. : 580.00
Dist.Para. : 20.00
Dist.Pas. : 20.00

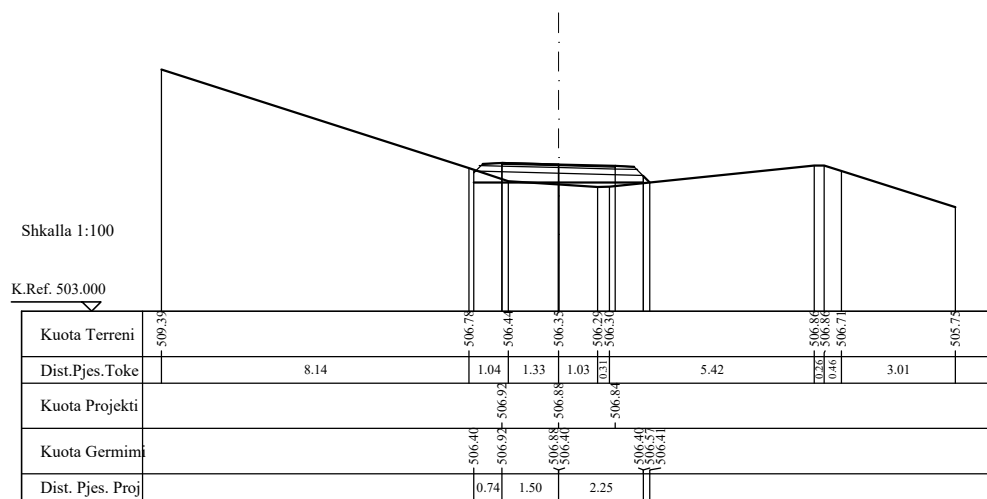

GERMIME	3.25 m ²
MBUSHJE	3.00 m ²
MBISTRUKTURA RRUGORE	
Shiresë Asfalobeton	3.00 m
Shiresë Banderi	3.00 m
Shiresë Stabilizanti	3.20 m
Shiresë Çakelli	3.49 m
BANKINE	1.00 m

Nr. Profili : 32
Kuot. Projekti : 501.72
Dist.Progr. : 620.00
Dist.Para. : 20.00
Dist.Pas. : 20.00

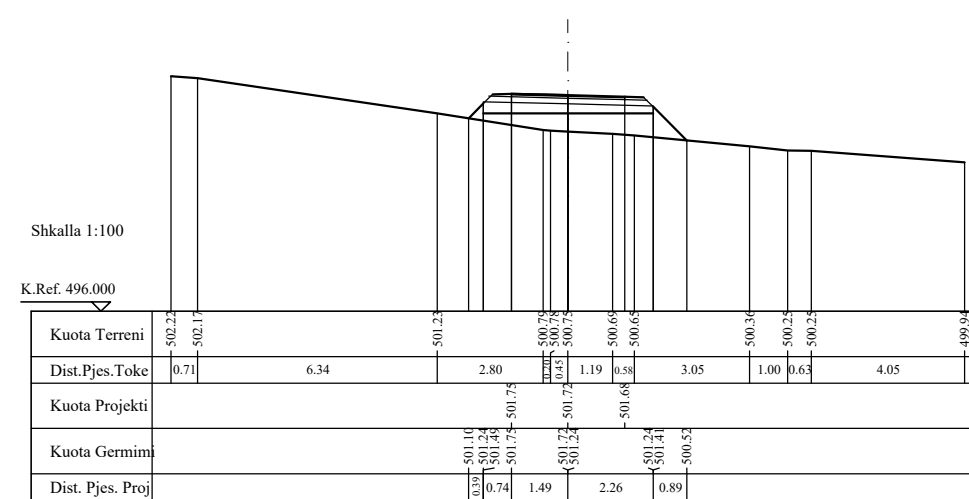

SISTEM-ASFALTIM I
RRUGES LAGJA RUSE -
JELLE, FSHATI HOMESH,
SHUPENZE,
BASHKIA BULQIZE

POROSITESI :
BASHKIA BULQIZE



PROJEKTUES :

"HYDRO-ENG CONSULTING"
sh.p.k



"IDEAL CONSTRUCTION
& PROJECTION"(I.C.P) sh.p.k



"P.C.S COMPANY" sh.p.k



GRUPI I PROJEKTIMIT

Ing.Hidroteknik Evis QYRKU	Nr. Licence K.1829/2
Ing. Ndertimi Alban DAUTAJ	Nr. Licence K.2232/2
Ing. Ndertimi Pamela KURTULAJ(ALIU)	Nr. Licence K.1474/3
Arkitekt Endrit TUZI	Nr. Licence A.0128/6
Ing.Topograf Maksim GEGA	Nr. Licence T.0455/4
Ing.Gjeodet Albin KOCI	Nr. Licence E.1269/2
Ing.Elektrik Edmond PALODHI	Nr. Licence E.1552
Ing.Gjeolog Asllan BASHA	Nr. Licence GJ.0686
Ing.Mjedisi Shpetim CIKU	Nr. Licence A.2443
Ing.Hidroteknik Xhuljana DAUTAJ(SULA)	Nr. Licence K.2232/2
Arkitekt Jorida GRABOVARI	Nr. Licence A.2595

FIRMA/VULA

SHENIME

TE DHENA TEKNIKE

FAZA E PROJEKTIT	PROJEKT ZBATIM
TIPI I FLETES	
EMERTIMI I FLETES	PROFILE TERTHOR SH 1:200

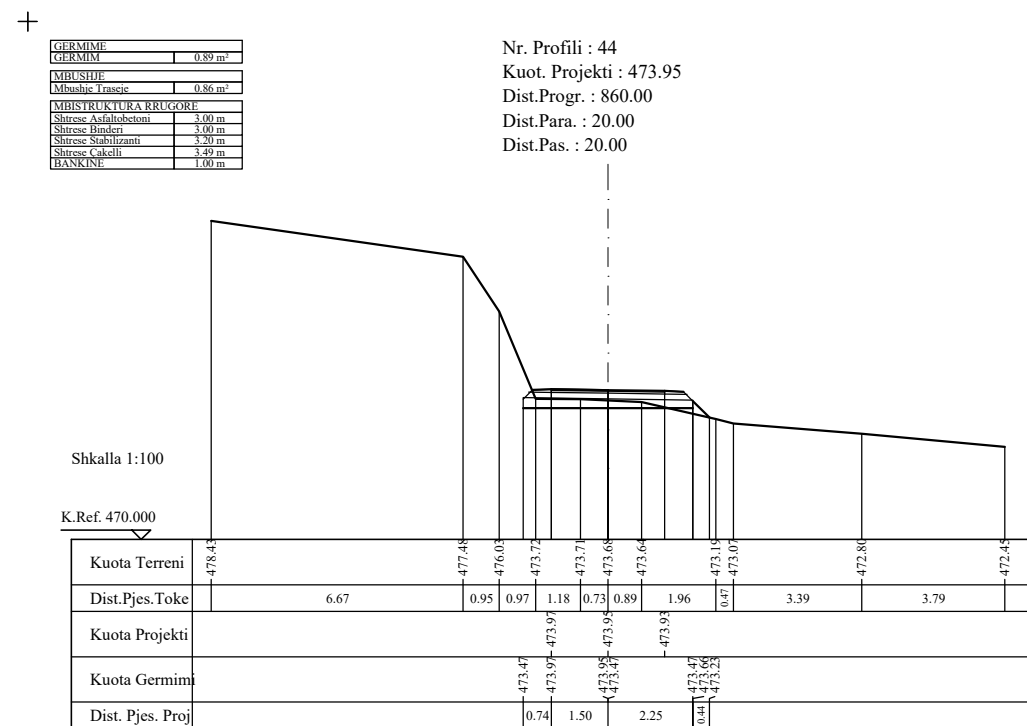
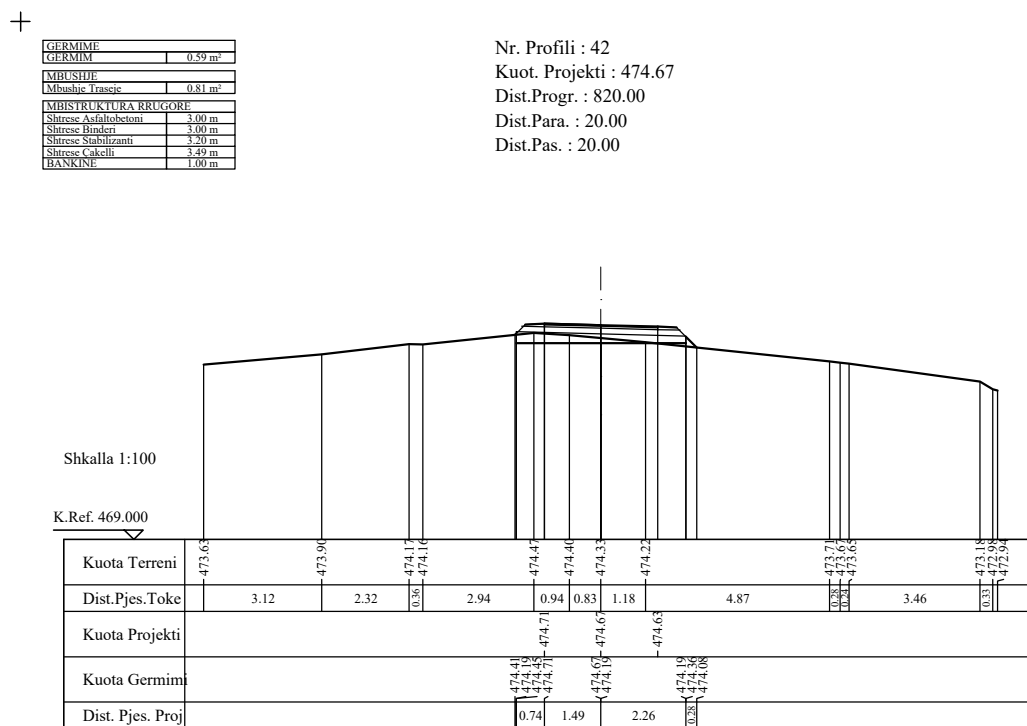
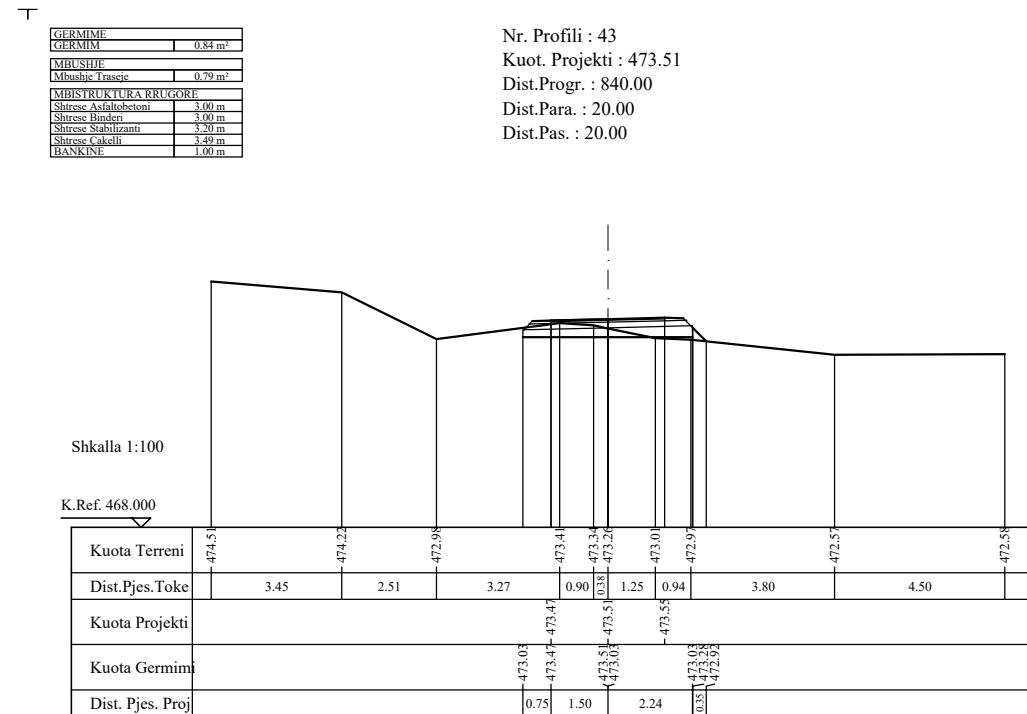
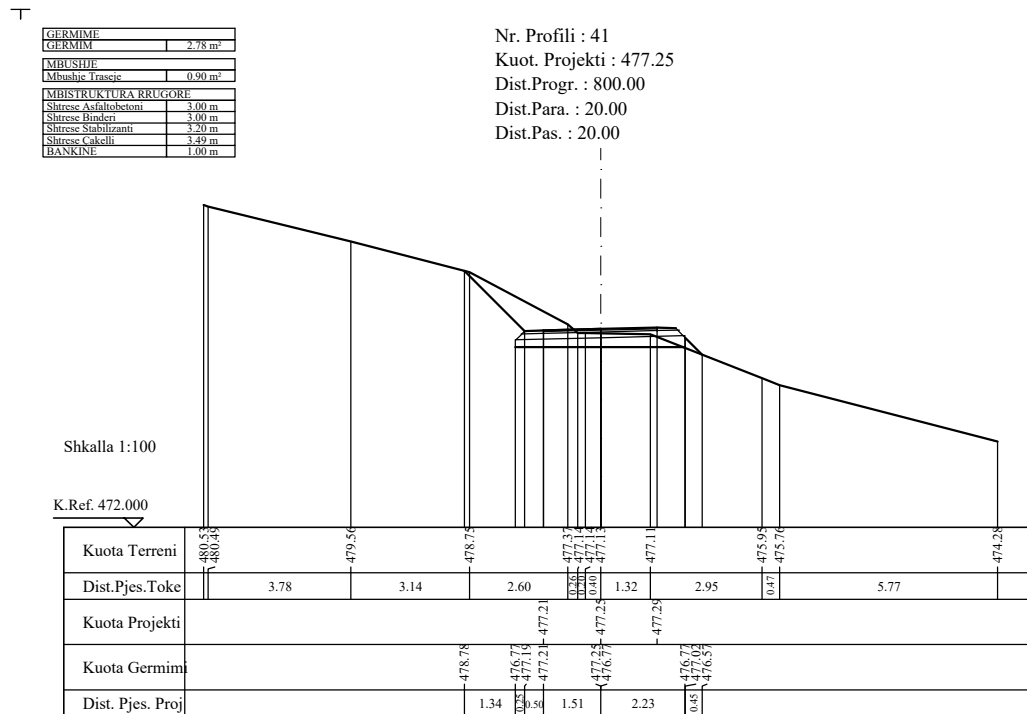

GERMIME	2.78 m ²
GERMIMI	
MBUSHJE	
Mbushje Traeje	0.90 m ²
MBISTRUKTURA RRUGORE	
Shtrese Asfaltobeton	3.00 m
Shtrese Binde	3.00 m
Shtrese Stabilizant	3.20 m
Shtrese Cakelli	3.49 m
BANKINE	1.00 m

GERMIME	0.84 m ²
GERMIMI	
MBUSHJE	
Mbushje Traeje	0.79 m ²
MBISTRUKTURA RRUGORE	
Shtrese Asfaltobeton	3.00 m
Shtrese Binde	3.00 m
Shtrese Stabilizant	3.20 m
Shtrese Cakelli	3.49 m
BANKINE	1.00 m

GERMIME	0.89 m ²
GERMIMI	
MBUSHJE	
Mbushje Traeje	0.86 m ²
MBISTRUKTURA RRUGORE	
Shtrese Asfaltobeton	3.00 m
Shtrese Binde	3.00 m
Shtrese Stabilizant	3.20 m
Shtrese Cakelli	3.49 m
BANKINE	1.00 m

SISTEM-ASFALTIM I
RRUGES LAGJA RUSE -
JELLE, FSHATI HOMESH,
SHUPENZE,
BASHKIA BULQIZE

POROSITESI :
BASHKIA BULQIZE



PROJEKTUES :

"HYDRO-ENG CONSULTING"
sh.p.k



"IDEAL CONSTRUCTION
& PROJECTION"(I.C.P) sh.p.k



"P.C.S COMPANY" sh.p.k



GRUPI I PROJEKTIMIT

Ing.Hidroteknik Evis QYRKU	Nr. Licence K.1829/2
Ing. Ndertimi Alban DAUTAJ	Nr. Licence K.2232/2
Ing. Ndertimi Pamela KURTULAJ(ALIU)	Nr. Licence K.1474/3
Arkitekt Endrit TUZI	Nr. Licence A.0128/6
Ing.Topograf Maksim GEGA	Nr. Licence T.0455/4
Ing.Gjeodet Albin KOCI	Nr. Licence E.1269/2
Ing.Elektrik Edmond PALODHI	Nr. Licence E.1552
Ing.Gjeolog Asllan BASHA	Nr. Licence GJ.0686
Ing.Mjedesi Shpetim CIKU	Nr. Licence A.2443
Ing.Hidroteknik Xhuljana DAUTA(SULA)	Nr. Licence K.2232/2
Arkitekt Jorida GRABOVARI	Nr. Licence A.2595

FIRMA/VULA

SHENIME

TE DHENA TEKNIKE

FAZA E PROJEKTIT	PROJEKT ZBATIM
TIPI I FLETES	
EMERTIMI I FLETES	PROFILE TERTHOR SH 1:200

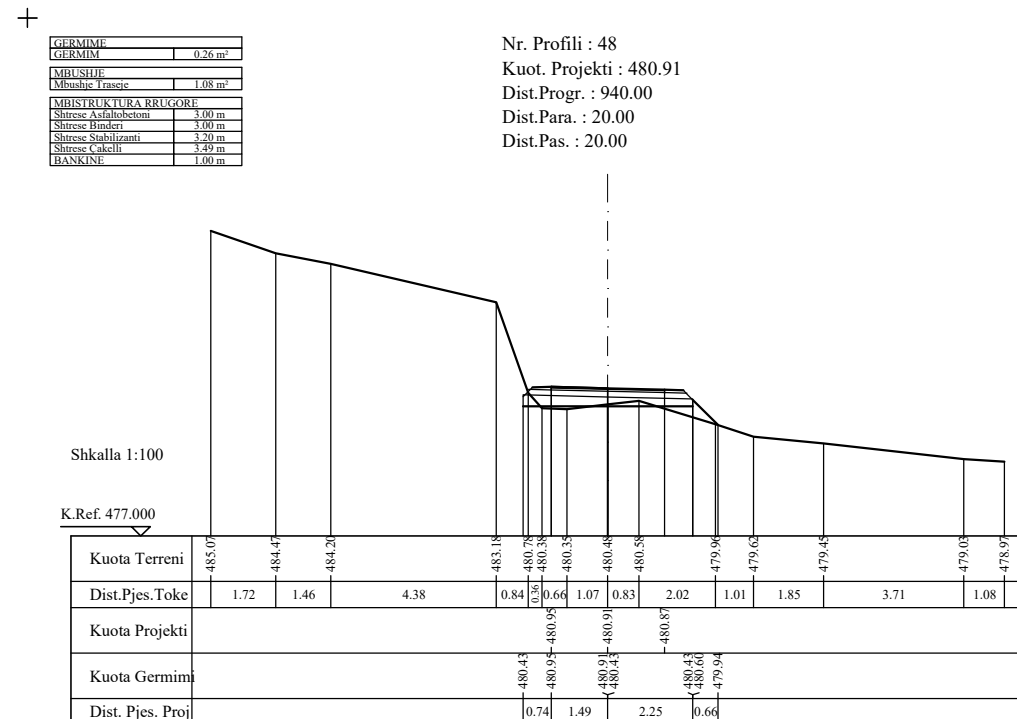
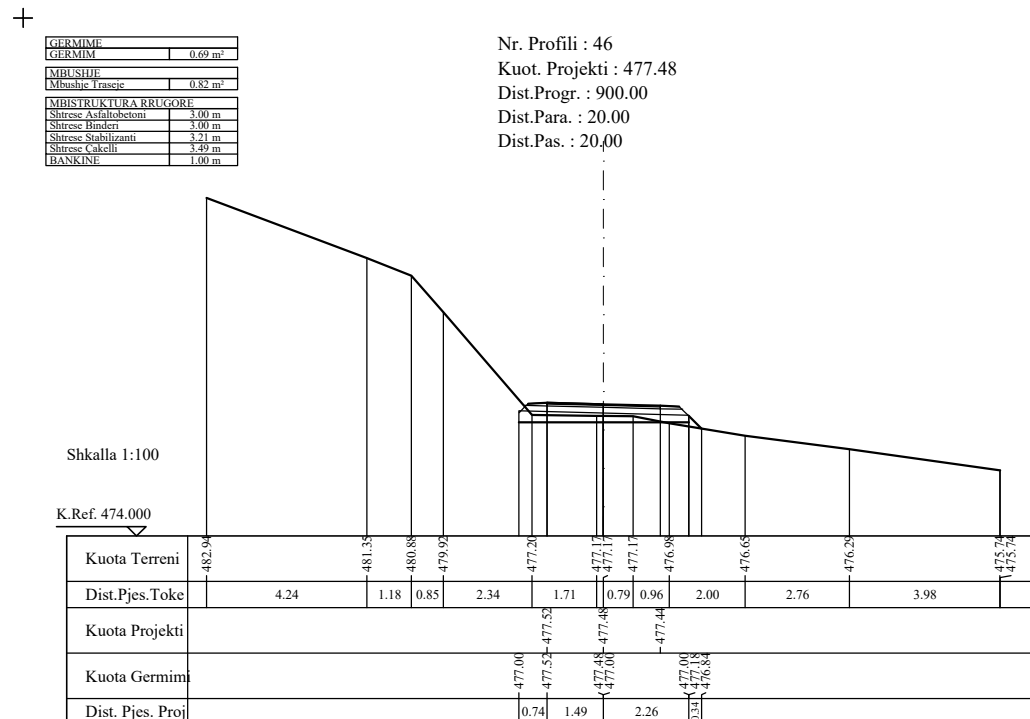
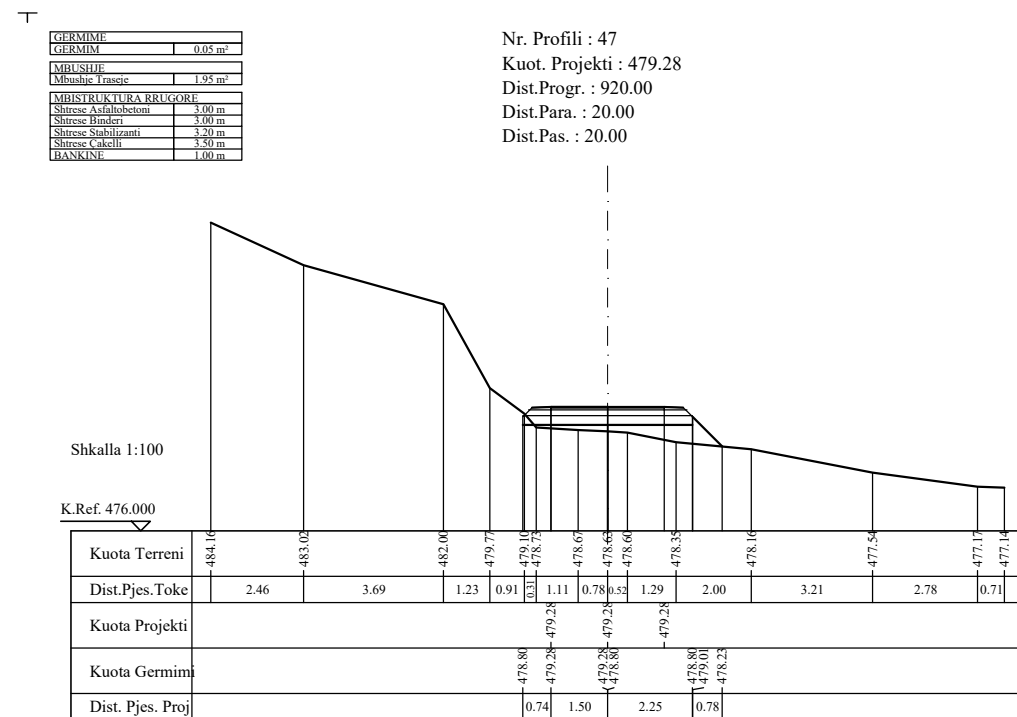
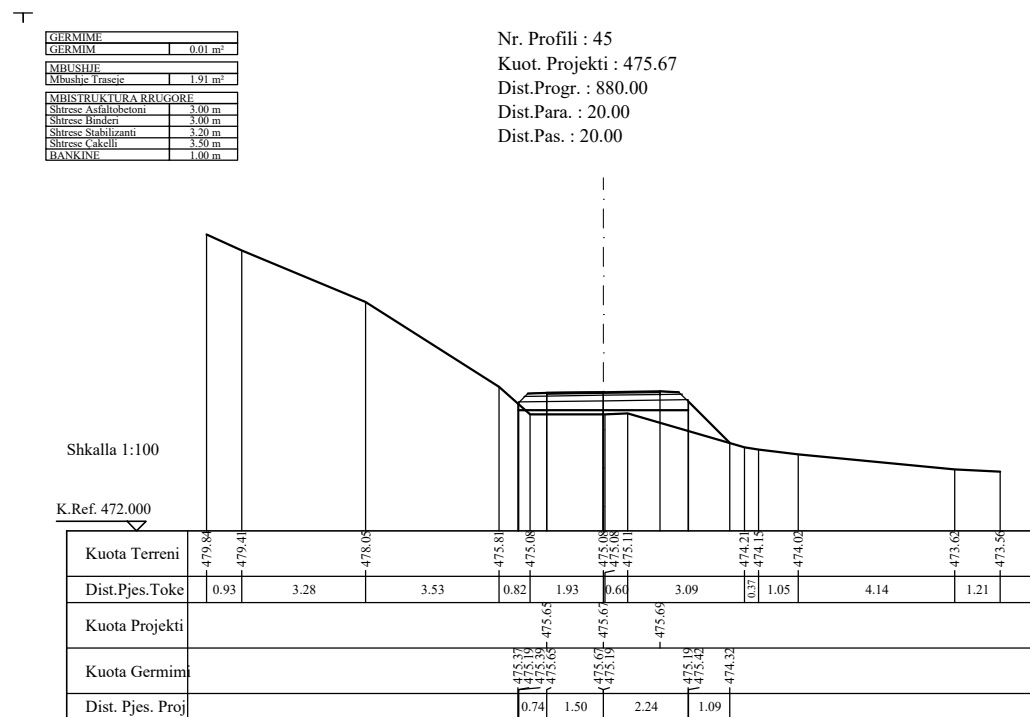

SISTEM-ASFALTIM I
RRUGES LAGJA RUSE -
JELLE, FSHATI HOMESH,
SHUPENZE,
BASHKIA BULQIZE

POROSITESI :
BASHKIA BULQIZE



PROJEKTUES :

"HYDRO-ENG CONSULTING"
sh.p.k



"IDEAL CONSTRUCTION
& PROJECTION"(I.C.P) sh.p.k



"P.C.S COMPANY" sh.p.k



GRUPI I PROJEKTIMIT

Ing.Hidroteknik Evis QYRKU	Nr. Licence K.1829/2
Ing. Ndertimi Alban DAUTAJ	Nr. Licence K.2232/2
Ing. Ndertimi Pamela KURTULAJ(ALIU)	Nr. Licence K.1474/3
Arkitekt Endrit TUZI	Nr. Licence A.0128/6
Ing.Topograf Maksim GEGA	Nr. Licence T.0455/4
Ing.Gjeodet Albin KOCI	Nr. Licence E.1269/2
Ing.Elektrik Edmond PALODHI	Nr. Licence E.1552
Ing.Gjeolog Asllan BASHA	Nr. Licence GJ.0686
Ing.Mjedisi Shpetim CIKU	Nr. Licence A.2443
Ing.Hidroteknik Xhuljana DAUTA(SULA)	Nr. Licence K.2232/2
Arkitekt Jorida GRABOVARI	Nr. Licence A.2595

FIRMA/VULA

SHENIME

TE DHENA TEKNIKE

FAZA E PROJEKTIT PROJEKT ZBATIM

TIPI I FLETES

EMERTIMI I FLETES PROFILE TERTHOR
SH 1:200

Nr. i fletes **A-20**

GERMIME	0.72 m ²
GERMIM	
MBUSHJE	
Mbushje Irasje	1.31 m ²
MBISTRUKTURA RRUGORE	
Shtrese Asfaltbetoni	3.00 m
Shtrese Banderi	3.00 m
Shtrese Stabilizanti	3.20 m
Shtrese Cakelli	3.49 m
BANKINE	1.00 m

Nr. Profili : 49
Kuot. Projekti : 482.33
Dist.Progr. : 960.00
Dist.Para. : 20.00
Dist.Pas. : 20.00

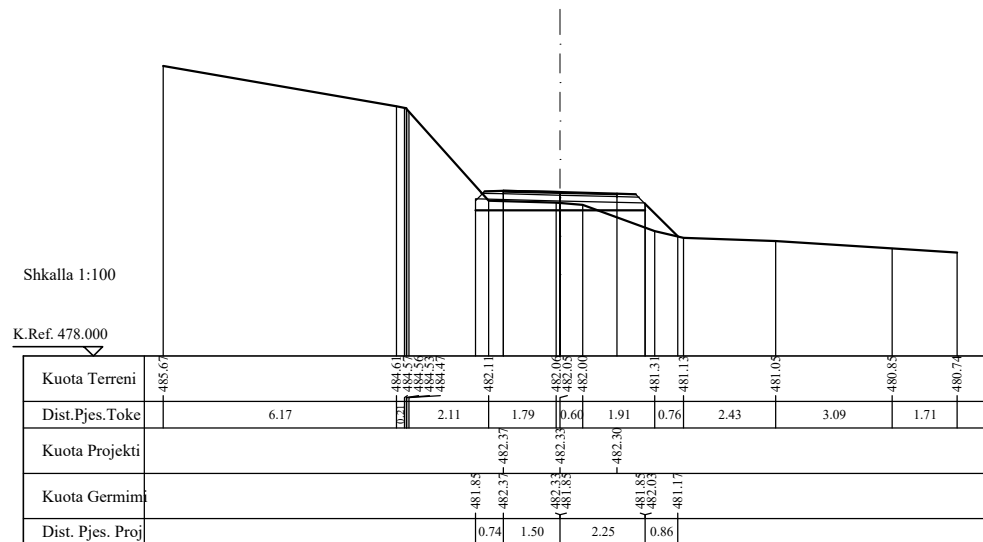

GERMIME	1.35 m ²
GERMIM	
MBUSHJE	
Mbushje Irasje	1.02 m ²
MBISTRUKTURA RRUGORE	
Shtrese Asfaltbetoni	3.00 m
Shtrese Banderi	3.00 m
Shtrese Stabilizanti	3.20 m
Shtrese Cakelli	3.49 m
BANKINE	1.00 m

Nr. Profili : 51
Kuot. Projekti : 484.80
Dist.Progr. : 1000.00
Dist.Para. : 20.00
Dist.Pas. : 20.00

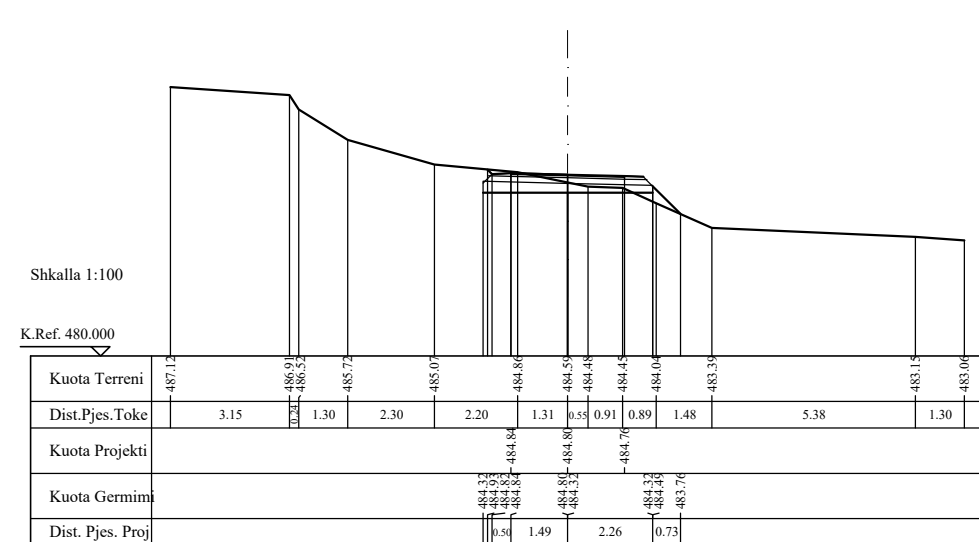

GERMIME	0.75 m ²
GERMIM	
MBUSHJE	
Mbushje Irasje	1.22 m ²
MBISTRUKTURA RRUGORE	
Shtrese Asfaltbetoni	3.00 m
Shtrese Banderi	3.00 m
Shtrese Stabilizanti	3.20 m
Shtrese Cakelli	3.49 m
BANKINE	1.00 m

Nr. Profili : 50
Kuot. Projekti : 483.59
Dist.Progr. : 980.00
Dist.Para. : 20.00
Dist.Pas. : 20.00

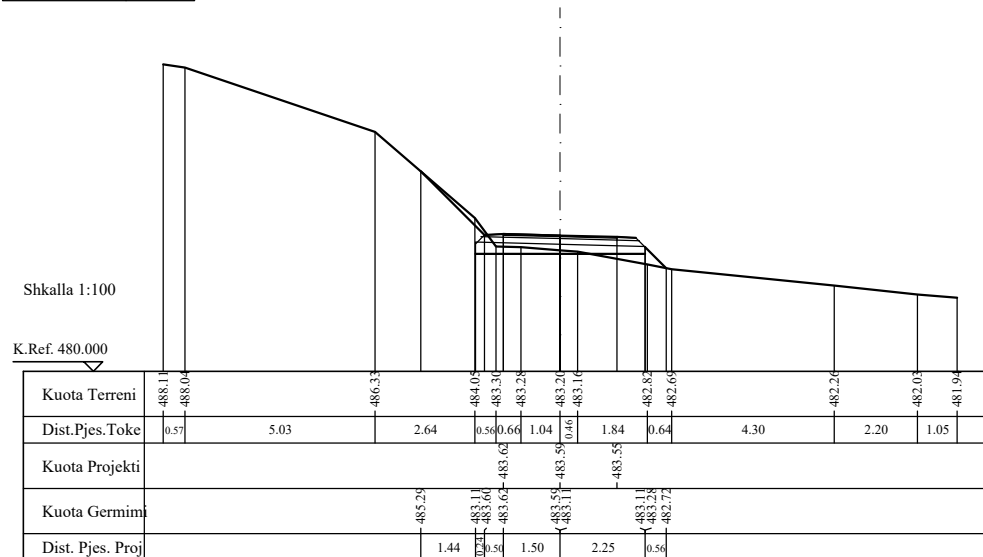

GERMIME	0.89 m ²
GERMIM	
MBUSHJE	
Mbushje Irasje	1.10 m ²
MBISTRUKTURA RRUGORE	
Shtrese Asfaltbetoni	3.00 m
Shtrese Banderi	3.00 m
Shtrese Stabilizanti	3.20 m
Shtrese Cakelli	3.49 m
BANKINE	1.00 m

Nr. Profili : 52
Kuot. Projekti : 485.64
Dist.Progr. : 1020.00
Dist.Para. : 20.00
Dist.Pas. : 20.00

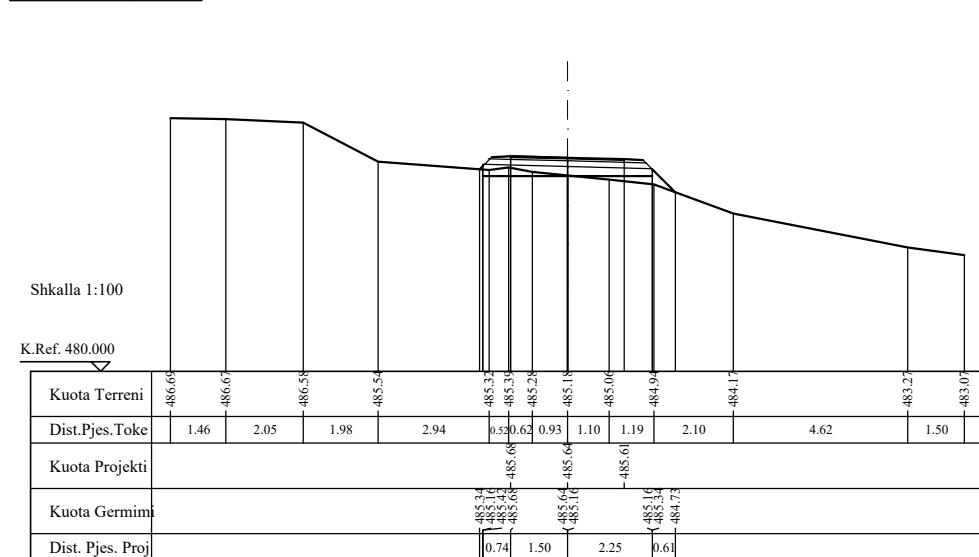

SISTEM-ASFALTIM I
RRUGES LAGJA RUSE -
JELLE, FSHATI HOMESH,
SHUPENZE,
BASHKIA BULQIZE

POROSITESI :
BASHKIA BULQIZE



PROJEKTUES :

"HYDRO-ENG CONSULTING"
sh.p.k



"IDEAL CONSTRUCTION
& PROJECTION"(I.C.P) sh.p.k



"P.C.S COMPANY" sh.p.k



GRUPI I PROJEKTIMIT

Ing.Hidroteknik Evis QYRKU	Nr. Licence K.1829/2
Ing. Ndertimi Alban DAUTAJ	Nr. Licence K.2232/2
Ing. Ndertimi Pamela KURTULAJ(ALIU)	Nr. Licence K.1474/3
Arkitekt Endrit TUZI	Nr. Licence A.0128/6
Ing.Topograf Maksim GEGA	Nr. Licence T.0455/4
Ing.Gjeodet Albin KOCI	Nr. Licence E.1269/2
Ing.Elektrik Edmond PALODHI	Nr. Licence E.1552
Ing.Gjeolog Asllan BASHA	Nr. Licence GJ.0686
Ing.Mjedisi Shpetim CIKU	Nr. Licence A.2443
Ing.Hidroteknik Xhuljana DAUTA(SULA)	Nr. Licence K.2232/2
Arkitekt Jorida GRABOVARI	Nr. Licence A.2595

FIRMA/VULA

SHENIME

TE DHENA TEKNIKE

FAZA E PROJEKTIT	PROJEKT ZBATIM
TIPI I FLETES	
EMERTIMI I FLETES	PROFILE TERTHOR SH 1:200

GERMIME	1.65 m ²
GERMIM	
MBUSHJE	0.72 m ²
Mbushje Traseje	
MBISTRUKTURA RRUGORE	
Shtrese Asfaltobetoni	3.00 m
Shtrese Bnderi	3.00 m
Shtrese Stabilizanti	3.31 m
Shtrese Cakelli	3.49 m
BANKINE	1.00 m

Nr. Profili : 53
Kuot. Projekti : 485.99
Dist.Progr. : 1040.00
Dist.Para. : 20.00
Dist.Pas. : 20.00

GERMIME	0.91 m ²
GERMIM	
MBUSHJE	0.75 m ²
Mbushje Traseje	
MBISTRUKTURA RRUGORE	
Shtrese Asfaltobetoni	3.00 m
Shtrese Bnderi	3.00 m
Shtrese Stabilizanti	3.30 m
Shtrese Cakelli	3.49 m
BANKINE	1.00 m

Nr. Profili : 55
Kuot. Projekti : 486.30
Dist.Progr. : 1080.00
Dist.Para. : 20.00
Dist.Pas. : 20.00

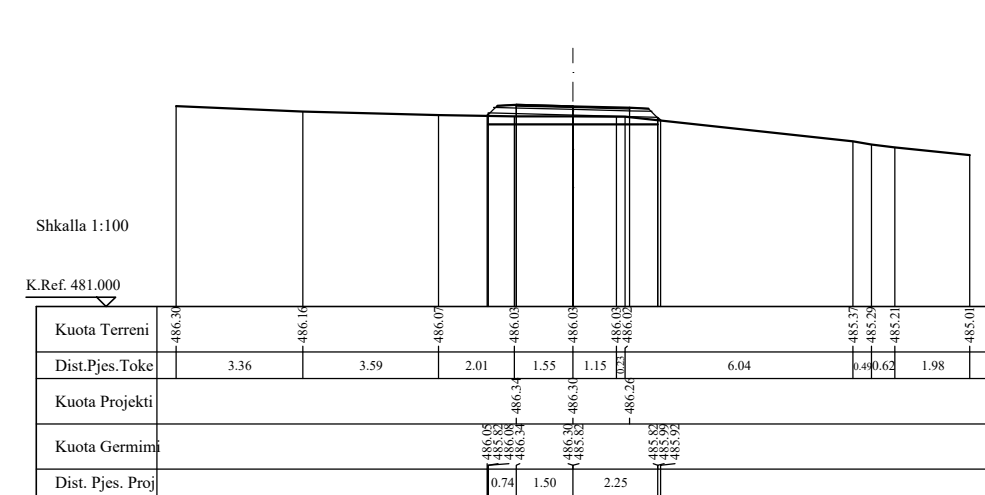
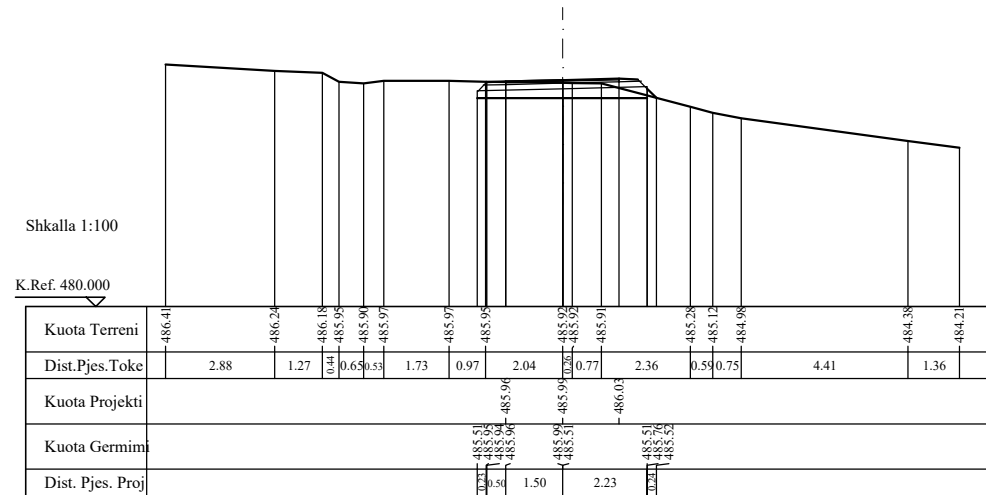

GERMIME	0.51 m ²
GERMIM	
MBUSHJE	0.72 m ²
Mbushje Traseje	
MBISTRUKTURA RRUGORE	
Shtrese Asfaltobetoni	3.00 m
Shtrese Bnderi	3.00 m
Shtrese Stabilizanti	3.31 m
Shtrese Cakelli	3.49 m
BANKINE	1.00 m

Nr. Profili : 54
Kuot. Projekti : 486.15
Dist.Progr. : 1060.00
Dist.Para. : 20.00
Dist.Pas. : 20.00

GERMIME	1.90 m ²
GERMIM	
MBUSHJE	0.75 m ²
Mbushje Traseje	
MBISTRUKTURA RRUGORE	
Shtrese Asfaltobetoni	3.00 m
Shtrese Bnderi	3.00 m
Shtrese Stabilizanti	3.30 m
Shtrese Cakelli	3.49 m
BANKINE	1.00 m

Nr. Profili : 56
Kuot. Projekti : 486.45
Dist.Progr. : 1100.00
Dist.Para. : 20.00
Dist.Pas. : 20.00

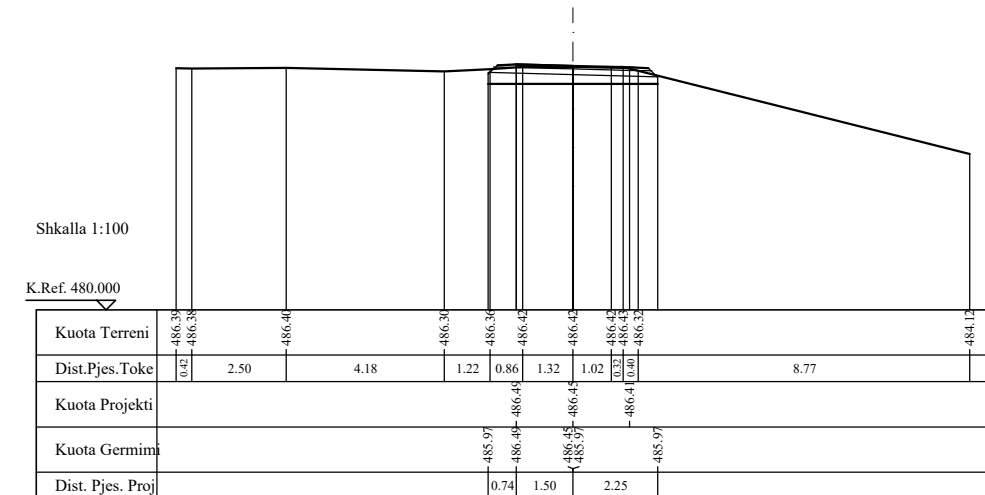
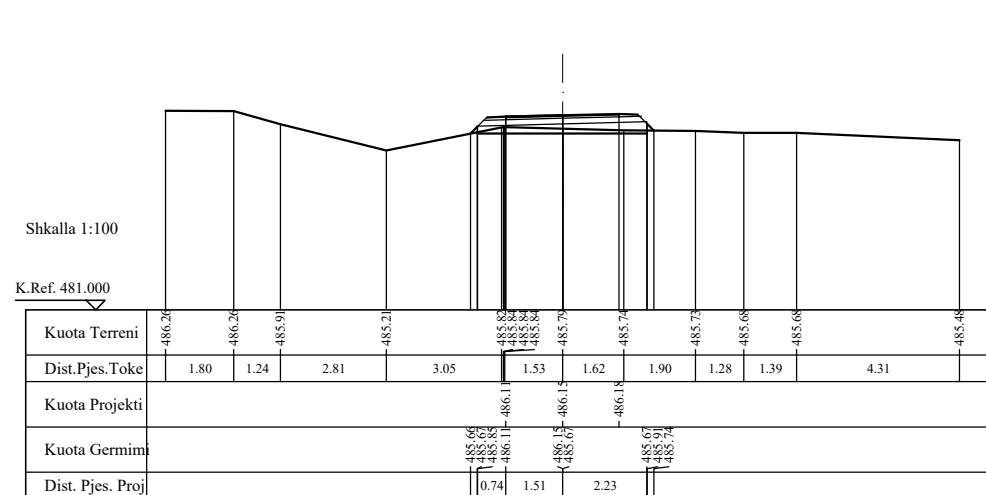

SISTEM-ASFALTIM I
RRUGES LAGJA RUSE -
JELLE, FSHATI HOMESH,
SHUPENZE,
BASHKIA BULQIZE

POROSITESI :
BASHKIA BULQIZE



PROJEKTUES :

"HYDRO-ENG CONSULTING"
sh.p.k



"IDEAL CONSTRUCTION
& PROJECTION"(I.C.P) sh.p.k



"P.C.S COMPANY" sh.p.k



GRUPI I PROJEKTIMIT

Ing.Hidroteknik Evis QYRKU	Nr. Licence K.1829/2
Ing. Ndertimi Alban DAUTAJ	Nr. Licence K.2232/2
Ing. Ndertimi Pamela KURTULAJ(ALIU)	Nr. Licence K.1474/3
Arkitekt Endrit TUZI	Nr. Licence A.0128/6
Ing.Topograf Maksim GEGA	Nr. Licence T.0455/4
Ing.Gjeodet Albin KOCI	Nr. Licence E.1269/2
Ing.Elektrik Edmond PALODHI	Nr. Licence E.1552
Ing.Gjeolog Asllan BASHA	Nr. Licence GJ.0686
Ing.Mjedisi Shpetim CIKU	Nr. Licence A.2443
Ing.Hidroteknik Xhuljana DAUTAJ(SULA)	Nr. Licence K.2232/2
Arkitekt Jorida GRABOVARI	Nr. Licence A.2595

FIRMA/VULA

SHENIME

TE DHENA TEKNIKE

FAZA E PROJEKTIT	PROJEKT ZBATIM
TIPI I FLETES	
EMERTIMI I FLETES	PROFILE TERTHOR SH 1:200

GERMIMI	
GERMIMI	2.03 m ²
MBUSHJE	
Mbushje Traseje	0.73 m ²
MBISTRUKTURA RRUGORE	
Shrese Asfalobeton	3.00 m
Shrese Banderi	3.00 m
Shrese Stabilizanti	3.30 m
Shrese Cakelli	3.49 m
BANKINE	1.00 m

Nr. Profili : 65
Kuot. Projekti : 486.13
Dist.Progr. : 1280.00
Dist.Para. : 20.00
Dist.Pas. : 12.93

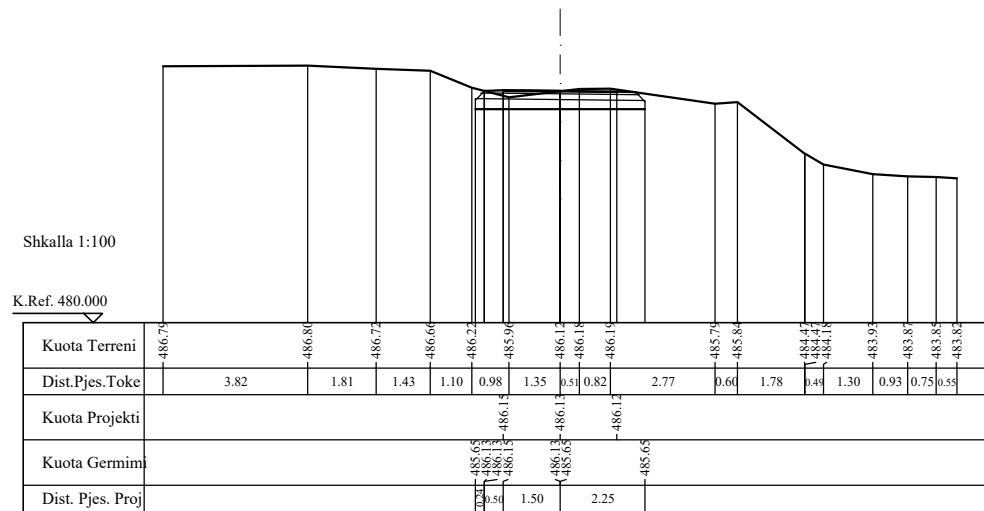

GERMIMI	
GERMIMI	3.50 m ²
MBUSHJE	
Mbushje Traseje	2.59 m ²
MBISTRUKTURA RRUGORE	
Shrese Asfalobeton	9.45 m
Shrese Banderi	9.45 m
Shrese Stabilizanti	9.65 m
Shrese Cakelli	9.94 m
BANKINE	1.00 m

Nr. Profili : 66
Kuot. Projekti : 485.78
Dist.Progr. : 1292.93
Dist.Para. : 12.93

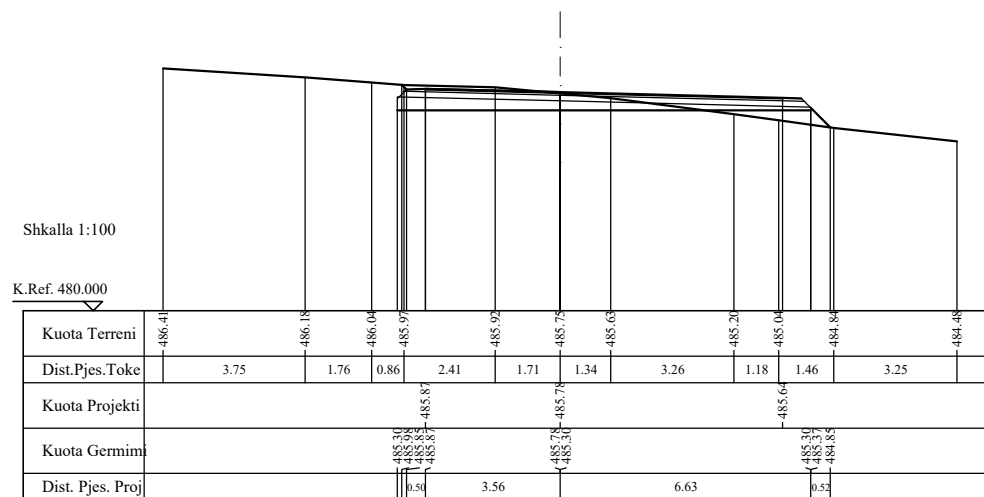

PROFILI GJATESOR SH H-1:1000 , V-1:100

Niveletat	Dif. Kuote Distanca Pjerrësia	h = 2.91 L = 31.47 i = 9.25%	h = -11.98 L = 175.65 i = -6.82%	h = 7.82 L = 79.49 i = 9.84%
------------------	-------------------------------------	------------------------------------	--	------------------------------------

R	250.00
T	20.09
Fr	-0.80
Pr	31.47
Qt	529.77

R	500.00
T	41.65
Fr	1.73
Pr	207.12
Qt	517.79

R	150.00
T	10.00
Fr	0.50
Pr	28.00
Qt	520.00

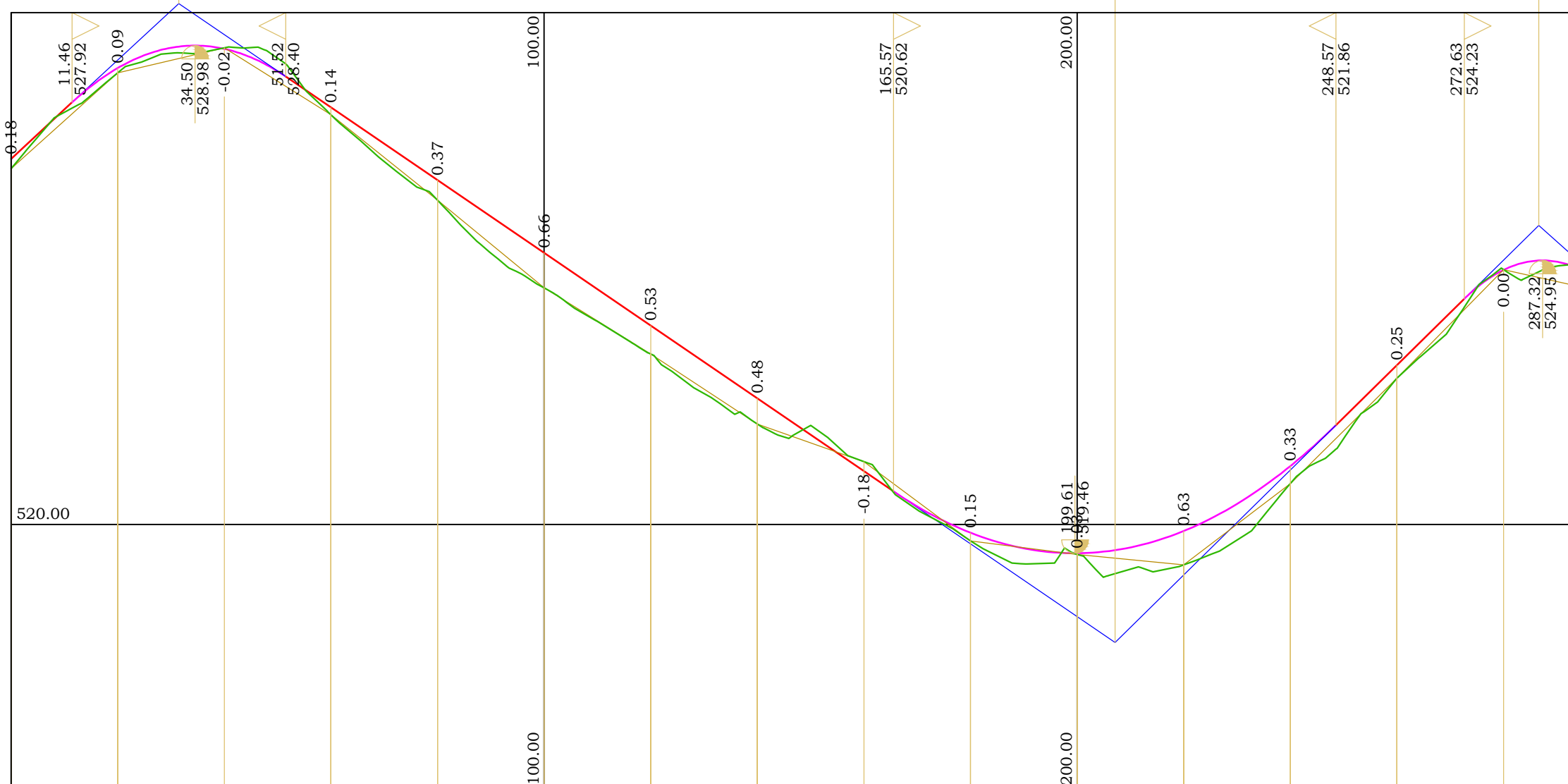

Sh Vertikale 1:100
Sh Horizontale 1:1000

K.Ref. 515.00

Nr. Profili	1	2	3	4	5	6	7	8	9	10	11	12	13	14	15	
Dist. Pjesore	20.00	20.00	20.00	20.00	20.00	20.00	20.00	20.00	20.00	20.00	20.00	20.00	20.00	20.00	20.00	
Dist. Progressive	0.00	20.00	40.00	60.00	80.00	100.00	120.00	140.00	160.00	180.00	200.00	220.00	240.00	260.00	280.00	
Kuote Toke	526.68	528.47	528.94	527.69	526.08	524.44	523.20	521.88	521.18	519.69	519.43	519.24	520.77	522.74	524.78	
Kuote Projekti	526.86	528.56	528.92	527.82	526.46	525.09	523.73	522.37	521.00	519.85	519.46	519.88	521.09	522.99	524.77	
Disnivel	0.18	0.09	-0.02	0.13	0.38	0.65	0.53	0.49	-0.18	0.16	0.03	0.64	0.32	0.25	-0.01	
Kilometrazhi	0					1					2					
Zhfill. Plan.																

O B J E K T I

**SISTEM-ASFALTIM I
RRUGES LAGJA RUSE -
JELLE, FSHATI HOMESH,
SHUPENZE,
BASHKIA BULQIZE**

**POROSITESI :
BASHKIA BULQIZE**



PROJEKTUES :

- "HYDRO-ENG CONSULTING " sh.p.k
- "IDEAL CONSTRUCTION & PROJECTION"(I.C.P) sh.p.k
- "P.C.S COMPANY " sh.p.k

GRUPI I PROJEKTIMIT

Ing.Hidroteknik Evis QYRKU	Nr. Licence K.1829/2
Ing. Ndertimi Alban DAUTAJ	Nr. Licence K.2232/2
Ing. Ndertimi Pamela KURTULAJ(ALIU)	Nr. Licence K.1474/3
Arkitekt Endrit TUZI	Nr. Licence A.0128/6
Ing.Topograf Maksim GEGA	Nr. Licence T.0455/4
Ing.Gjeodet Albin KOCI	Nr. Licence E.1269/2
Ing.Elektrik Edmond PALODHI	Nr. Licence E.1552
Ing.Gjeolog Asllan BASHA	Nr. Licence GJ.0686
Ing.Mjedisi Shpetim CIKU	Nr. Licence A.2443
Ing.Hidroteknik Xhuljana DAUTAJ(SULA)	Nr. Licence K.2232/2
Arkitekt Jorida GRABOVARI	Nr. Licence A.2595

FIRMA/VULA

SHENIME

TE DHENA TEKNIKE

FAZA E PROJEKTIT	PROJEKT ZBATIM
TIPI I FLETES	
EMERTIMI I FLETES	PROFILI GJATESOR SH H-1:1000 , V-1:100

PROFILI GJATESOR SH H-1:1000 , V-1:100

O B J E K T I

SISTEM-ASFALTIM I
RRUGES LAGJA RUSE -
JELLE, FSHATI HOMESH,
SHUPENZE,
BASHKIA BULQIZE

POROSITESI :
BASHKIA BULQIZE



PROJEKTUES :

"HYDRO-ENG CONSULTING"
sh.p.k



"IDEAL CONSTRUCTION
& PROJECTION"(I.C.P) sh.p.k



"P.C.S COMPANY" sh.p.k



GRUPI I PROJEKTIMIT

Ing.Hidroteknik Evis QYRKU	Nr. Licence K.1829/2
Ing. Ndertimi Alban DAUTAJ	Nr. Licence K.2232/2
Ing. Ndertimi Pamela KURTULAJ(ALIU)	Nr. Licence K.1474/3
Arkitekt Endrit TUZI	Nr. Licence A.0128/6
Ing.Topograf Maksim GEGA	Nr. Licence T.0455/4
Ing.Gjeodet Albin KOCI	Nr. Licence E.1269/2
Ing.Elektrik Edmond PALODHI	Nr. Licence E.1552
Ing.Gjeolog Asllan BASHA	Nr. Licence GJ.0686
Ing.Mjedisi Shpetim CIKU	Nr. Licence A.2443
Ing.Hidroteknik Xhuljana DAUTAJ(SULA)	Nr. Licence K.2232/2
Arkitekt Jorida GRABOVARI	Nr. Licence A.2595

FIRMA/VULA

SHENIME

TE DHENA TEKNIKE

FAZA E PROJEKTIT PROJEKT ZBATIM

TIPI I FLETES

EMERTIMI I FLETES PROFILI GJATESOR
SH H-1:1000 , V-1:100

Nr. i fletes **A-26**

Niveletat

Dif. Kuote
Distanca
Pjerrësia

h = -5.42
L = 60.88
i = -8.90%

h = 1.12
L = 61.45
i = 1.82%

h = -4.79
L = 61.90
i = -7.74%

h = -3.61
L = 23.49
i = -15.35%

h = -3.18
L = 63.60
i = -5.01%

R	150.00
T	14.05
Fr	-0.65
Pr	286.62
Qt	525.61

R	400.00
T	21.42
Fr	0.57
Pr	347.50
Qt	520.19

R	200.00
T	9.56
Fr	-0.23
Pr	408.95
Qt	521.31

R	250.00	250.00
T	13.39	12.93
Fr	-0.18	0.33
Pr	470.85	494.33
Qt	510.52	512.91

R	250.00
T	9.8
Fr	-0.1
Pr	557.9
Qt	509.7

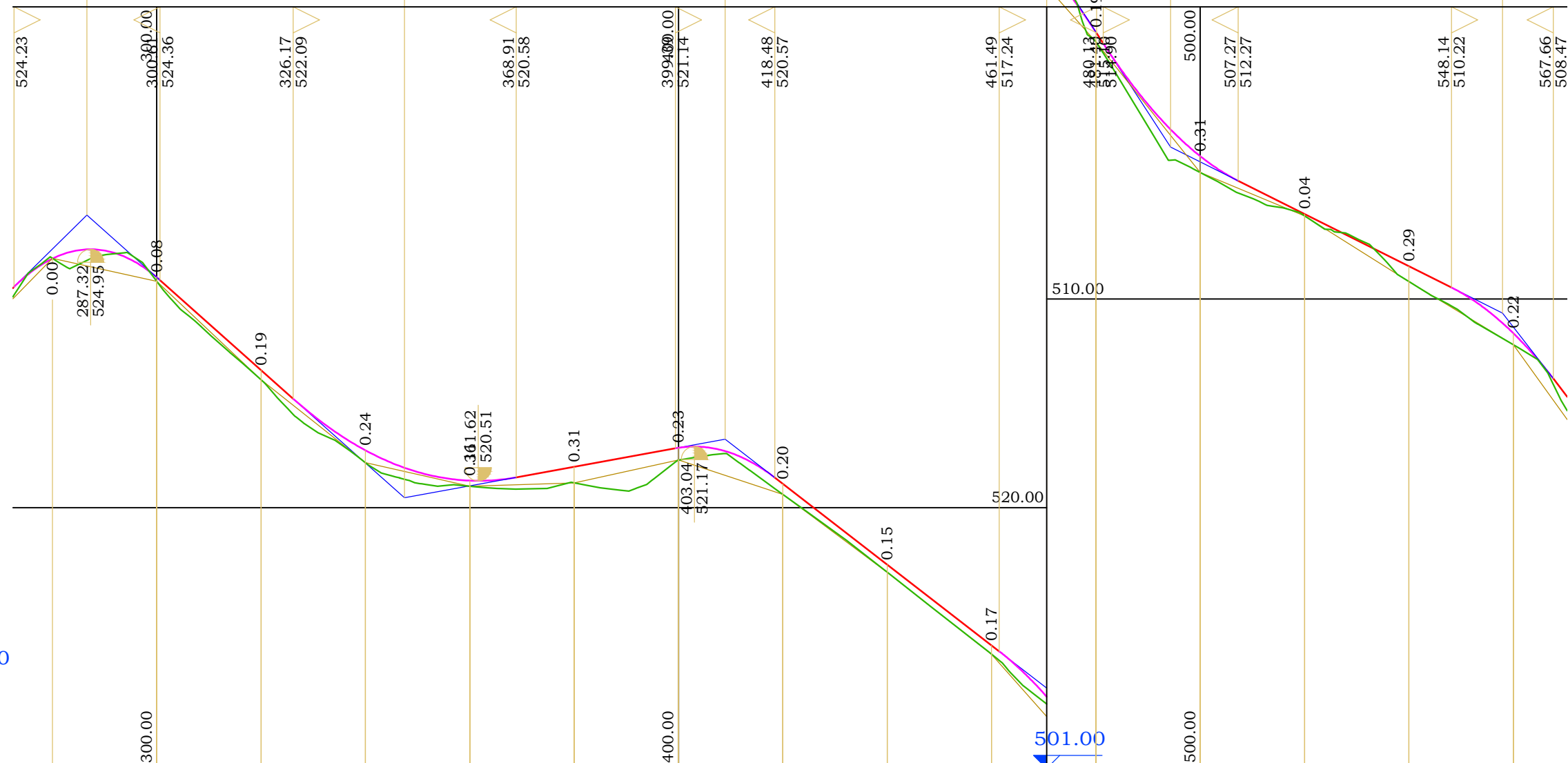

Sh Vertikale 1:100
Sh Horizontale 1:1000

K.Ref. 515.00

Nr. Profili	15	16	17	18	19	20	21	22	23	24	25	26	27	28	29	
Dist. Pjesore	0	20.00	20.00	20.00	20.00	20.00	20.00	20.00	20.00	20.00	20.00	20.00	20.00	20.00	20.00	
Dist. Progressive		280.00	300.00	320.00	340.00	360.00	380.00	400.00	420.00	440.00	460.00	480.00	500.00	520.00	540.00	560.00
Kuote Toke		524.78	524.34	522.45	520.86	520.41	520.91	520.25	518.76	517.19	514.93	512.43	511.59	510.34	509.12	
Kuote Projekti		524.77	524.42	522.64	521.10	520.52	521.15	520.46	518.91	517.36	515.11	512.74	511.63	510.63	509.34	
Disnivel		-0.01	0.08	0.19	0.24	0.11	0.08	0.31	0.15	0.17	0.18	0.31	0.04	0.29	0.22	
Kilometrazhi		3				4						5				
Zhvill. Plan.	04 a=7.03 Sv= 11.35 a=14.46		Sv= 14.99 a=47.71		Sv= 12.80 a=8.15		Sv= 3.79 a=4.83		Sv= 16.38 a=20.86		Sv= 26.9					
	R=100.00	L=13.69	R=50.00	L=10.74	R=20.00	L=8.12	R=100.00	L=8.46	R=50.00	L=14	R=50.00	L=21.75	R=50.00	L=7.05	R=50.00	L=7.92
				Sv=8.46	a=26.92	L=31.68		Sv=9.91	a=6.31	L=45.68	Sv=3.55	a=4.52	R=50.00	L=18	Sv=24.84	a=31.62
				R=20.00				R=100.00			R=50.00			R=50.00		

PROFILI GJATESOR SH H-1:1000 , V-1:100

OBJEKTI

**SISTEM-ASFALTIM I
RRUGES LAGJA RUSE -
JELLE, FSHATI HOMESH,
SHUPENZE,
BASHKIA BULQIZE**

**POROSITESI :
BASHKIA BULQIZE**



PROJEKTUES :

"HYDRO-ENG CONSULTING" sh.p.k

"IDEAL CONSTRUCTION & PROJECTION"(I.C.P) sh.p.k

"P.C.S COMPANY" sh.p.k

GRUPI I PROJEKTIMIT

Ing.Hidroteknik Evis QYRKU	Nr. Licence K.1829/2
Ing. Ndertimi Alban DAUTAJ	Nr. Licence K.2232/2
Ing. Ndertimi Pamela KURTULAJ(ALIU)	Nr. Licence K.1474/3
Arkitekt Endrit TUZI	Nr. Licence A.0128/6
Ing.Topograf Maksim GEGA	Nr. Licence T.0455/4
Ing.Gjeodet Albin KOCI	Nr. Licence E.1269/2
Ing.Elektrik Edmond PALODHI	Nr. Licence E.1552
Ing.Gjeolog Asllan BASHA	Nr. Licence GJ.0686
Ing.Mjedisi Shpetim CIKU	Nr. Licence A.2443
Ing.Hidroteknik Xhuljana DAUTAJ(SULA)	Nr. Licence K.2232/2
Arkitekt Jorida GRABOVARI	Nr. Licence A.2595

FIRMA/VULA

SHENIME

TE DHENA TEKNIKE

FAZA E PROJEKTIT PROJEKT ZBATIM

TIPI I FLETES

EMERTIMI I FLETES PROFILI GJATESOR SH H-1:1000 , V-1:100

Nr. i fletes A-28

Niveletat	Dif. Kuote Distanca Pjerrësia	h = -6.71 L = 48.26 i = -13.91%	h = 9.27 L = 102.09 i = 9.08%	h = 4.65 L = 75.64 i = 6.15%	h = 0.85 L = 111.65 i = 0.76%
-----------	-------------------------------------	---------------------------------------	-------------------------------------	------------------------------------	-------------------------------------

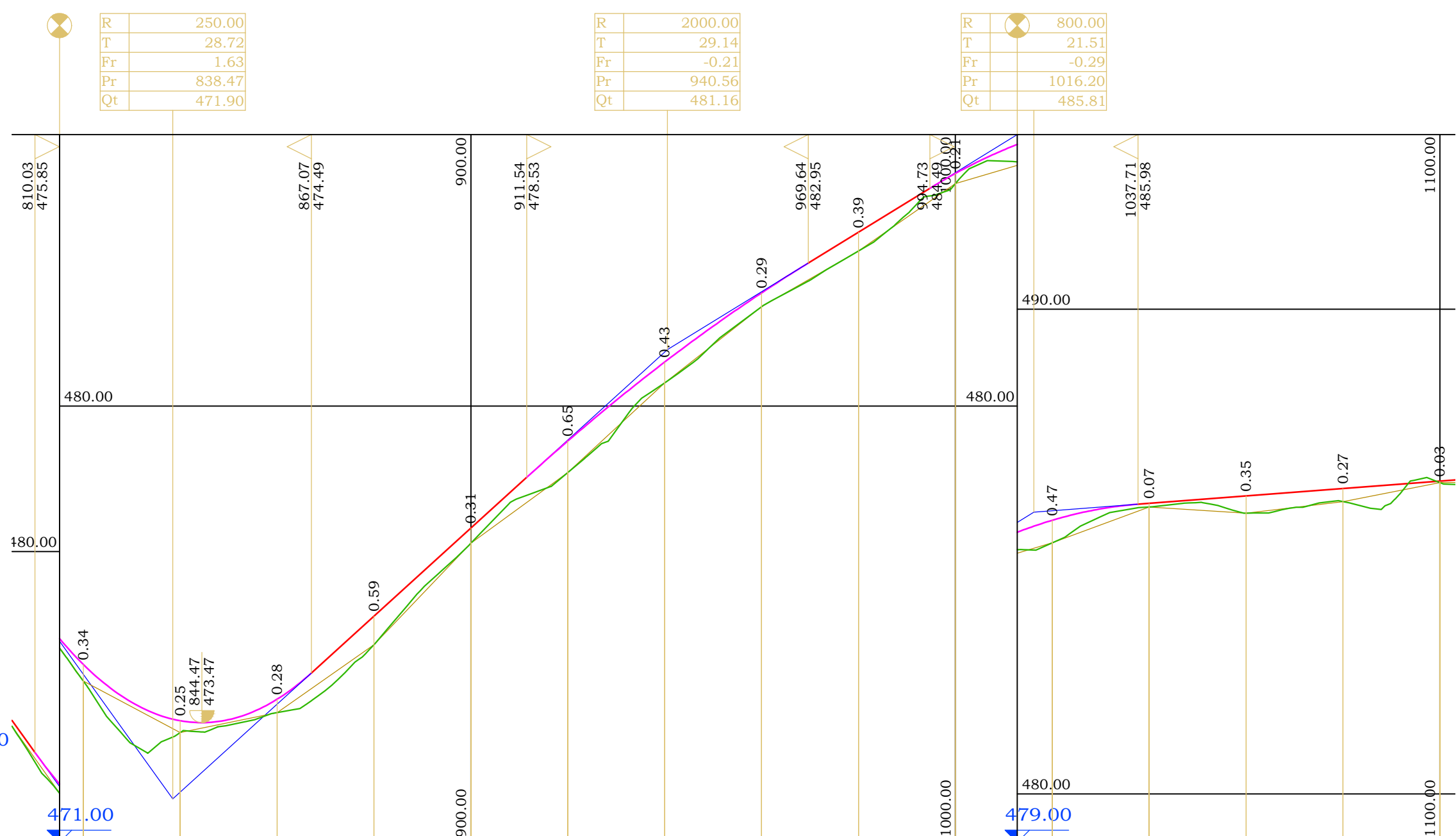

Sh Vertikale 1:100
Sh Horizontale 1:1000

K.Ref. 515.00 471.00

Nr. Profili	42	43	44	45	46	47	48	49	50	51	52	53	54	55	56	
Dist. Pjesore	20.00	20.00	20.00	20.00	20.00	20.00	20.00	20.00	20.00	20.00	20.00	20.00	20.00	20.00	20.00	
Dist. Progressive		820.00	840.00	860.00	880.00	900.00	920.00	940.00	960.00	980.00	1000.00	1020.00	1040.00	1060.00	1080.00	1100.00
Kuote Toke		474.33	473.26	473.68	475.08	477.17	478.63	480.48	482.05	483.20	484.59	485.18	485.92	486.15	486.03	486.42
Kuote Projekti		474.67	473.51	473.95	475.67	477.48	479.28	480.91	482.33	483.59	484.80	485.64	485.99	486.15	486.30	486.45
Disnivel		0.34	0.25	0.27	0.59	0.31	0.65	0.43	0.28	0.39	0.21	0.46	0.07	0.36	0.27	0.03
Kilometrazhi					9					10					11	
Zhfill. Plan.	<div style="display: flex; justify-content: space-between;"> <div style="width: 20%;"> <p>3.99 a=44.54 R=20.00 L=15.94</p> </div> <div style="width: 20%;"> <p>Sv= 2.94 a=7.48 R=50.00 L=18.41</p> </div> <div style="width: 20%;"> <p>Sv= 22.71 a=14.46 R=100.00 L=14.12</p> </div> <div style="width: 20%;"> <p>Sv= 11.94 a=7.60 R=100.00 L=8.81</p> </div> <div style="width: 20%;"> <p>Sv= 16.87 a=42.95 R=25.00 L=9.93</p> </div> <div style="width: 20%;"> <p>Sv= 2.57 a=5.45 R=30.00 L=24.76</p> </div> <div style="width: 20%;"> <p>Sv= 4.15 a=13.22 R=28.00 L=11.41</p> </div> <div style="width: 20%;"> <p>Sv= 9.32 R=50.00 L=8.89</p> </div> </div>															

PROFILI GJATESOR SH H-1:1000 , V-1:100

Niveletat	Dif. Kuote Distanca Pjerrësia	h = 0.85 L = 111.65 i = 0.76%	h = -0.54 L = 94.57 i = -0.57%	h = 0.70 L = 32.10 i = 2.17%	h = -1.04 L = 38.42 i = -2.70%
-----------	-------------------------------------	-------------------------------------	--------------------------------------	------------------------------------	--------------------------------------

R	1000.00
T	6.66
Fr	-0.02
Pr	1127.84
Qt	486.66

R	500.00
T	6.86
Fr	0.05
Pr	1222.42
Qt	486.12

R	500.00
T	12.17
Fr	-0.15
Pr	1254.52
Qt	486.82

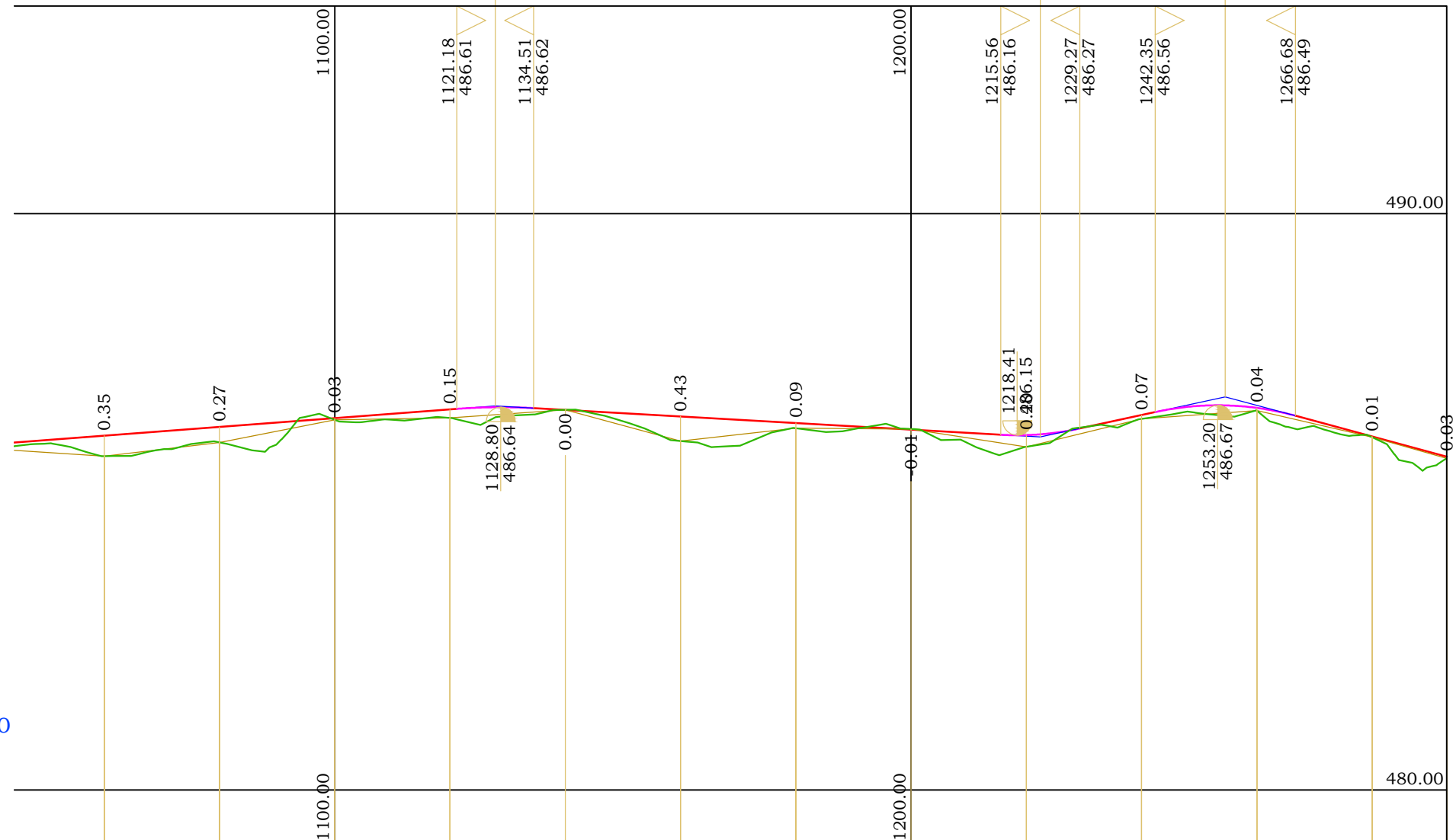

Sh Vertikale 1:100
Sh Horizontale 1:1000

K.Ref. 515.00

Nr. Profili	54	55	56	57	58	59	60	61	62	63	64	65	66	
Dist. Pjesore	20.00	20.00	20.00	20.00	20.00	20.00	20.00	20.00	20.00	20.00	20.00	20.00	12.93	
Dist. Progressive		1060.00	1080.00	1100.00	1120.00	1140.00	1160.00	1180.00	1200.00	1220.00	1240.00	1260.00	1280.00	1292.93
Kuote Toke		485.79	486.03	486.42	486.45	486.59	486.05	486.28	485.95	486.44	486.58	486.12	485.75	
Kuote Projekti		486.15	486.30	486.45	486.60	486.59	486.36	486.25	486.16	486.50	486.63	486.13	485.78	
Disnivel		0.36	0.27	0.03	0.15	0.00	0.43	0.08	0.21	0.06	0.05	0.01	0.03	
Kilometrazhi			11					12						
Zhfill. Plan.	<div style="display: flex; justify-content: space-between; font-size: small;"> <div style="width: 25%;"> <p>Sv= 4.15 a=13.22</p> <p>L= 11.41 R= 20.00</p> <p>L= 11.41 R= 20.00</p> <p>Sv= 7.82 a=9.95</p> <p>R= 50.00</p> </div> <div style="width: 25%;"> <p>Sv= 9.33 a=29.70</p> <p>L= 8.89 R= 20.00</p> <p>L= 33.19</p> <p>R= 80.00</p> </div> <div style="width: 25%;"> <p>Sv= 22.33 a=17.77</p> <p>L= 18.76</p> <p>R= 50.00</p> </div> <div style="width: 25%;"> <p>Sv= 2.96 a=3.77</p> <p>L= 11.89 R= 50.00</p> <p>L= 10.91</p> <p>Sv= 16.45 a=20.94</p> <p>R= 50.00</p> </div> </div>													

O B J E K T I

SISTEM-ASFALTIM I
RRUGES LAGJA RUSE -
JELLE, FSHATI HOMESH,
SHUPENZE,
BASHKIA BULQIZE

POROSITESI :
BASHKIA BULQIZE



PROJEKTUES :

- "HYDRO-ENG CONSULTING " sh.p.k
- "IDEAL CONSTRUCTION & PROJECTION"(I.C.P) sh.p.k
- "P.C.S COMPANY " sh.p.k

GRUPI I PROJEKTIMIT

Ing.Hidroteknik Evis QYRKU	Nr. Licence K.1829/2
Ing. Ndertimi Alban DAUTAJ	Nr. Licence K.2232/2
Ing. Ndertimi Pamela KURTULAJ(ALIU)	Nr. Licence K.1474/3
Arkitekt Endrit TUZI	Nr. Licence A.0128/6
Ing.Topograf Maksim GEGA	Nr. Licence T.0455/4
Ing.Gjeodet Albin KOCI	Nr. Licence E.1269/2
Ing.Elektrik Edmond PALODHI	Nr. Licence E.1552
Ing.Gjeolog Asllan BASHA	Nr. Licence GJ.0686
Ing.Mjedisi Shpetim CIKU	Nr. Licence A.2443
Ing.Hidroteknik Xhuljana DAUTAJ(SULA)	Nr. Licence K.2232/2
Arkitekt Jorida GRABOVARI	Nr. Licence A.2595

FIRMA/VULA

SHENIME

TE DHENA TEKNIKE

FAZA E PROJEKTIT	PROJEKT ZBATIM
TIPI I FLETES	
EMERTIMI I FLETES	PROFILI GJATESOR SH H-1:1000 , V-1:100

PLANIMETRIA E RRUGES SH 1: 1000

O B J E K T I

SISTEM-ASFALTIM I
RRUGES LAGJA RUSE -
JELLE, FSHATI HOMESH,
SHUPENZE,
BASHKIA BULQIZE

POROSITESI :
BASHKIA BULQIZE



PROJEKTUES :

"HYDRO-ENG CONSULTING"
sh.p.k



"IDEAL CONSTRUCTION
& PROJECTION"(I.C.P) sh.p.k



"P.C.S COMPANY" sh.p.k



GRUPI I PROJEKTIMIT

Ing.Hidroteknik Evis QYRKU	Nr. Licence K.1829/2
Ing. Ndertimi Alban DAUTAJ	Nr. Licence K.2232/2
Ing. Ndertimi Pamela KURTULAJ(ALIU)	Nr. Licence K.1474/3
Arkitekt Endrit TUZI	Nr. Licence A.0128/6
Ing.Topograf Maksim GEGA	Nr. Licence T.0455/4
Ing.Gjeodet Albin KOCI	Nr. Licence E.1269/2
Ing.Elektrik Edmond PALODHI	Nr. Licence E.1552
Ing.Gjeolog Aslan BASHA	Nr. Licence GJ.0686
Ing.Mjedisi Shpetim CIKU	Nr. Licence A.2443
Ing.Hidroteknik Xhuljana DAUTAJ(SULA)	Nr. Licence K.2232/2
Arkitekt Jorida GRABOVARI	Nr. Licence A.2595

FIRMA/VULA

SHENIME

TE DHENA TEKNIKE

FAZA E PROJEKTIT	PROJEKT ZBATIM
TIPI I FLETES	
EMERTIMI I FLETES	PLANIMETRIA 1:1000

Nr. i fletes **A-30**

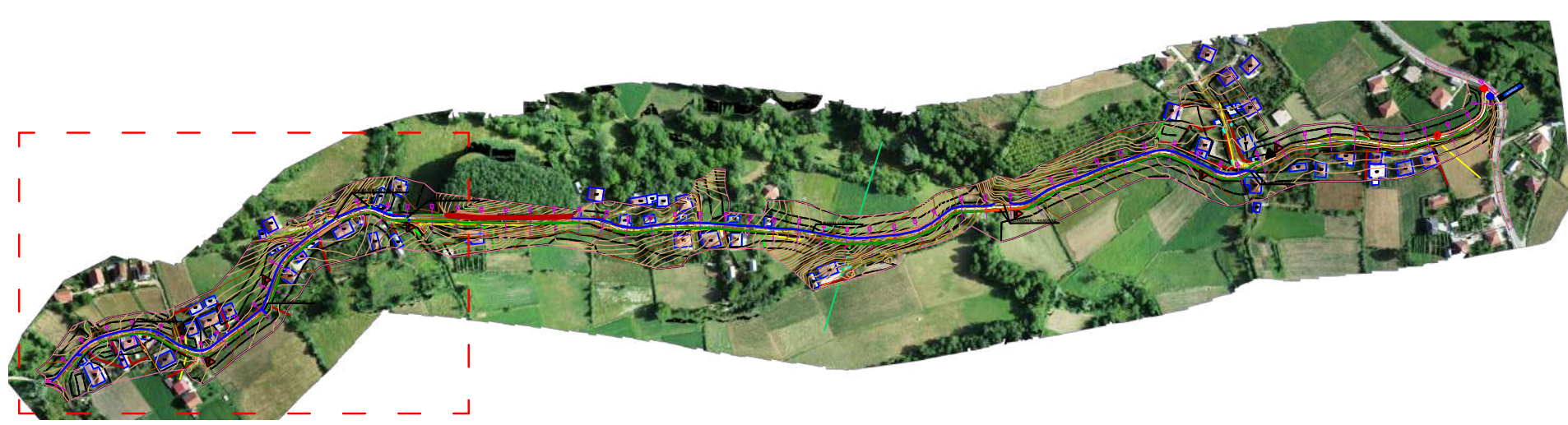
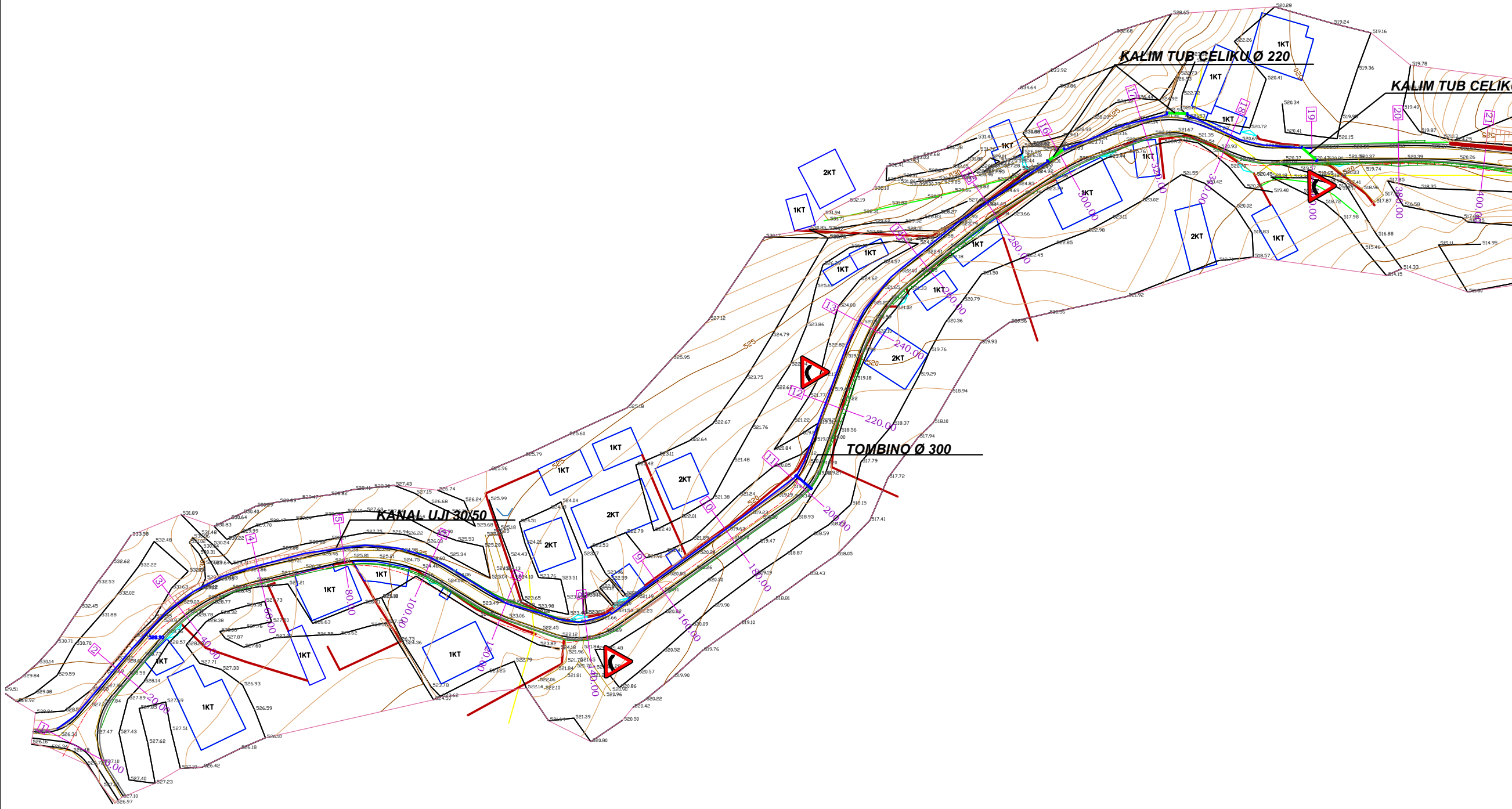

PLANIMETRIA E RRUGES SH 1: 1000

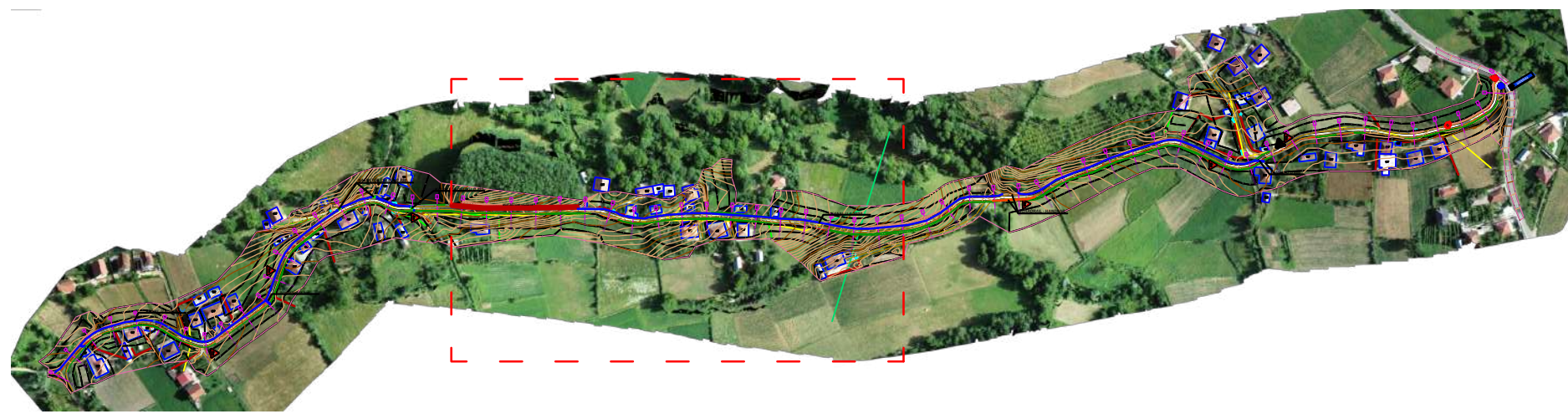
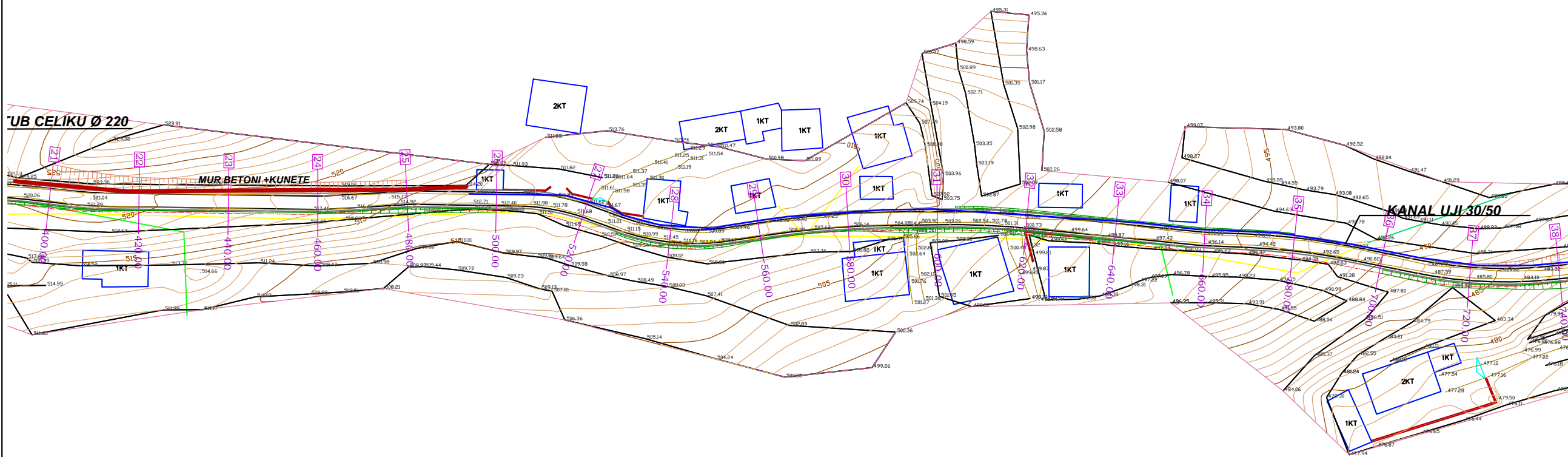

O B J E K T I

SISTEM-ASFALTIM I
RRUGES LAGJA RUSE -
JELLE, FSHATI HOMESH,
SHUPENZE,
BASHKIA BULQIZE

POROSITESI :
BASHKIA BULQIZE



PROJEKTUES :

"HYDRO-ENG CONSULTING"
sh.p.k



"IDEAL CONSTRUCTION
& PROJECTION"(I.C.P) sh.p.k



"P.C.S COMPANY" sh.p.k



GRUPI I PROJEKTIMIT

Ing.Hidroteknik Evis QYRKU	Nr. Licence K.1829/2
Ing. Ndertimi Alban DAUTAJ	Nr. Licence K.2232/2
Ing. Ndertimi Pamela KURTULAJ(ALIU)	Nr. Licence K.1474/3
Arkitekt Endrit TUZI	Nr. Licence A.0128/6
Ing.Topograf Maksim GEGA	Nr. Licence T.0455/4
Ing.Gjeodet Albin KOCI	Nr. Licence E.1269/2
Ing.Elektrik Edmond PALODHI	Nr. Licence E.1552
Ing.Gjeolog Asllan BASHA	Nr. Licence GJ.0686
Ing.Mjedisi Shpetim CIKU	Nr. Licence A.2443
Ing.Hidroteknik Xhujana DAUTAJ(SULA)	Nr. Licence K.2232/2
Arkitekt Jorida GRABOVARI	Nr. Licence A.2595

FIRMA/VULA

SHENIME

TE DHENA TEKNIKE

FAZA E PROJEKTIT	PROJEKT ZBATIM
TIPI I FLETES	
EMERTIMI I FLETES	PLANIMETRIA 1:1000

Nr. i fletes **A-31**

PLANIMETRIA E RRUGES SH 1: 1000

O B J E K T I

SISTEM-ASFALTIM I
RRUGES LAGJA RUSE -
JELLE, FSHATI HOMESH,
SHUPENZE,
BASHKIA BULQIZE

POROSITESI :
BASHKIA BULQIZE



PROJEKTUES :

"HYDRO-ENG CONSULTING"
sh.p.k



"IDEAL CONSTRUCTION
& PROJECTION"(I.C.P) sh.p.k



"P.C.S COMPANY" sh.p.k



GRUPI I PROJEKTIMIT

Ing.Hidroteknik Evis QYRKU	Nr. Licence K.1829/2
Ing. Ndertimi Alban DAUTAJ	Nr. Licence K.2232/2
Ing. Ndertimi Pamela KURTULAJ(ALIU)	Nr. Licence K.1474/3
Arkitekt Endrit TUZI	Nr. Licence A.0128/6
Ing.Topograf Maksim GEGA	Nr. Licence T.0455/4
Ing.Gjeodet Albin KOCI	Nr. Licence E.1269/2
Ing.Elektrik Edmond PALODHI	Nr. Licence E.1552
Ing.Gjeolog Asllan BASHA	Nr. Licence GJ.0686
Ing.Mjedisi Shpetim CIKU	Nr. Licence A.2443
Ing.Hidroteknik Xhuljana DAUTAJ(SULA)	Nr. Licence K.2232/2
Arkitekt Jorida GRABOVARI	Nr. Licence A.2595

FIRMA/VULA

SHENIME

TE DHENA TEKNIKE

FAZA E PROJEKTIT	PROJEKT ZBATIM
TIPI I FLETES	
EMERTIMI I FLETES	PLANIMETRIA 1:1000

Nr. i fletes **A-32**



PLANIMETRIA E RRUGES SH 1: 1000

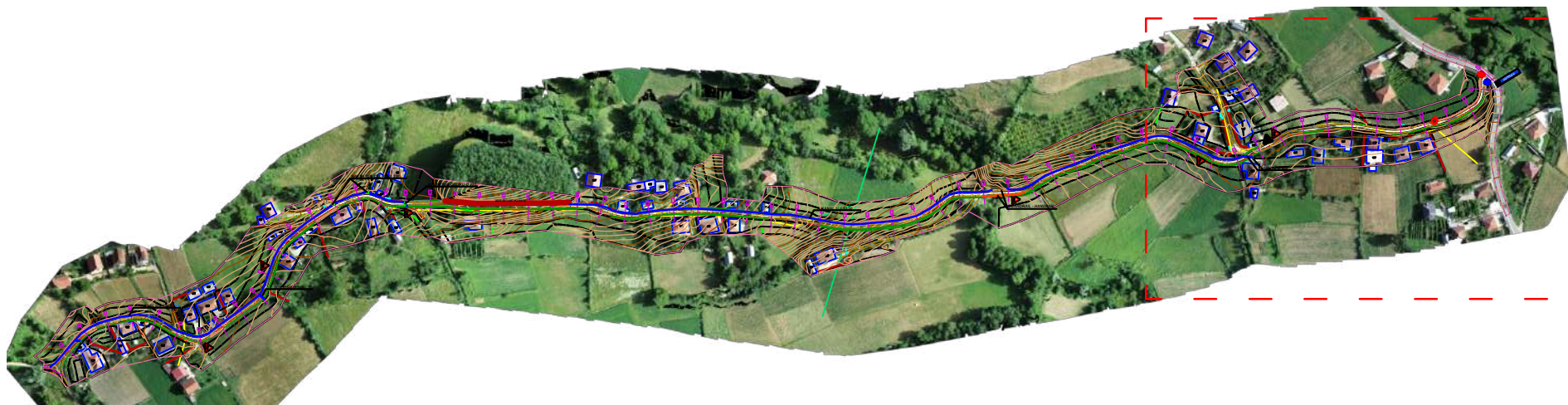
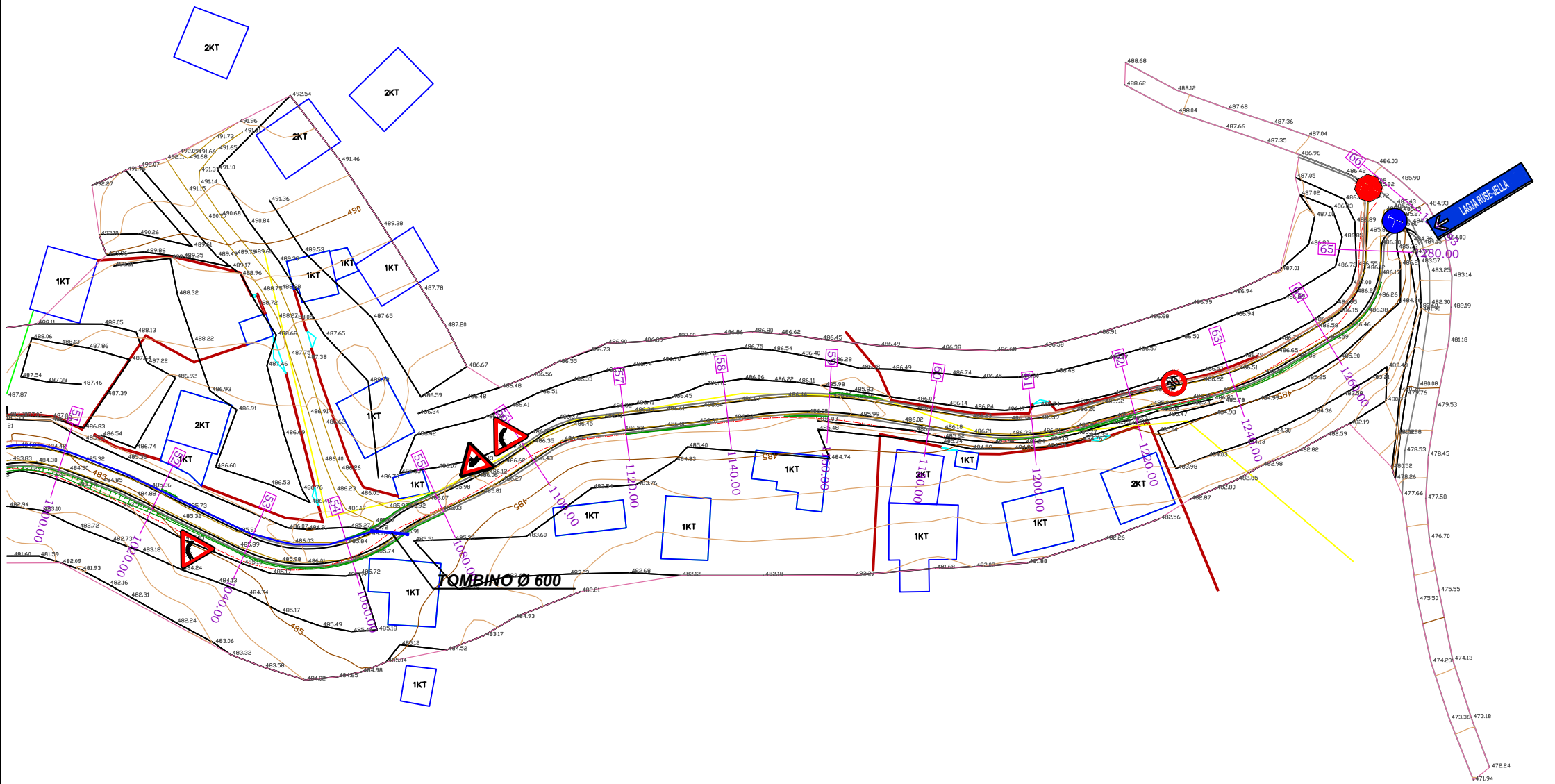

O B J E K T I

SISTEM-ASFALTIM I
RRUGES LAGJA RUSE -
JELLE, FSHATI HOMESH,
SHUPENZE,
BASHKIA BULQIZE

POROSITESI :
BASHKIA BULQIZE



PROJEKTUES :

"HYDRO-ENG CONSULTING"
sh.p.k



"IDEAL CONSTRUCTION
& PROJECTION"(I.C.P) sh.p.k



"P.C.S COMPANY" sh.p.k



GRUPI I PROJEKTIMIT

Ing.Hidroteknik Evis QYRKU	Nr. Licence K.1829/2
Ing. Ndertimi Alban DAUTAJ	Nr. Licence K.2232/2
Ing. Ndertimi Pamela KURTULAJ(ALIU)	Nr. Licence K.1474/3
Arkitekt Endrit TUZI	Nr. Licence A.0128/6
Ing.Topograf Maksim GEGA	Nr. Licence T.0455/4
Ing.Gjeodet Albin KOCI	Nr. Licence E.1269/2
Ing.Elektrik Edmond PALODHI	Nr. Licence E.1552
Ing.Gjeolog Asilan BASHA	Nr. Licence GJ.0686
Ing.Mjedisi Shpetim CIKU	Nr. Licence A.2443
Ing.Hidroteknik Xhuljana DAUTAJ(SULA)	Nr. Licence K.2232/2
Arkitekt Jorida GRABOVARI	Nr. Licence A.2595

FIRMA/VULA

SHENIME

TE DHENA TEKNIKE

FAZA E PROJEKTIT	PROJEKT ZBATIM
TIPI I FLETES	
EMERTIMI I FLETES	PLANIMETRIA 1:1000

Nr. i fletes **A-33**

SINJALISTIKA- RRUGA RUSE JELLE SH 1: 1000



SISTEM-ASFALTIM I
RRUGES LAGJA RUSE -
JELLE, FSHATI HOMESH,
SHUPENZE,
BASHKIA BULQIZE

POROSITESI :



PROJEKTUES :

"HYDRO-ENG CONSULTING"
sh.p.k



"IDEAL CONSTRUCTION
& PROJECTION"(I.C.P) sh.p.k



"P.C.S COMPANY" sh.p.k



GRUPI I PROJEKTIMIT

Ing.Hidroteknik Evis QYRKU	Nr. Licence K.1829/2
Ing. Ndertimi Alban DAUTAJ	Nr. Licence K.2232/2
Ing. Ndertimi Pamela KURTULAJ(ALIU)	Nr. Licence K.1474/3
Arkitekt Endrit TUZI	Nr. Licence A.0128/6
Ing.Topograf Maksim GEGA	Nr. Licence T.0455/4
Ing.Gjeodet Albin KOCI	Nr. Licence E.1269/2
Ing.Elektrik Edmond PALODHI	Nr. Licence E.1552
Ing.Gjeolog Asllan BASHA	Nr. Licence GJ.0686
Ing.Mjedisi Shpetim CIKU	Nr. Licence A.2443
Ing.Hidroteknik Xhuljana DAUTAJ(SULA)	Nr. Licence K.2232/2
Arkitekt Jorida GRABOVARI	Nr. Licence A.2595

FIRMA/VULA

SHENIME

TE DHENA TEKNIKE

FAZA E PROJEKTIT	PROJEKT ZBATIM
TIPI I FLETES	
EMERTIMI I FLETES	PLANIMETRIA 1:1000

Nr. i fletes A-34

SINJALISTIKA- RRUGA RUSE JELLE SH 1: 1000

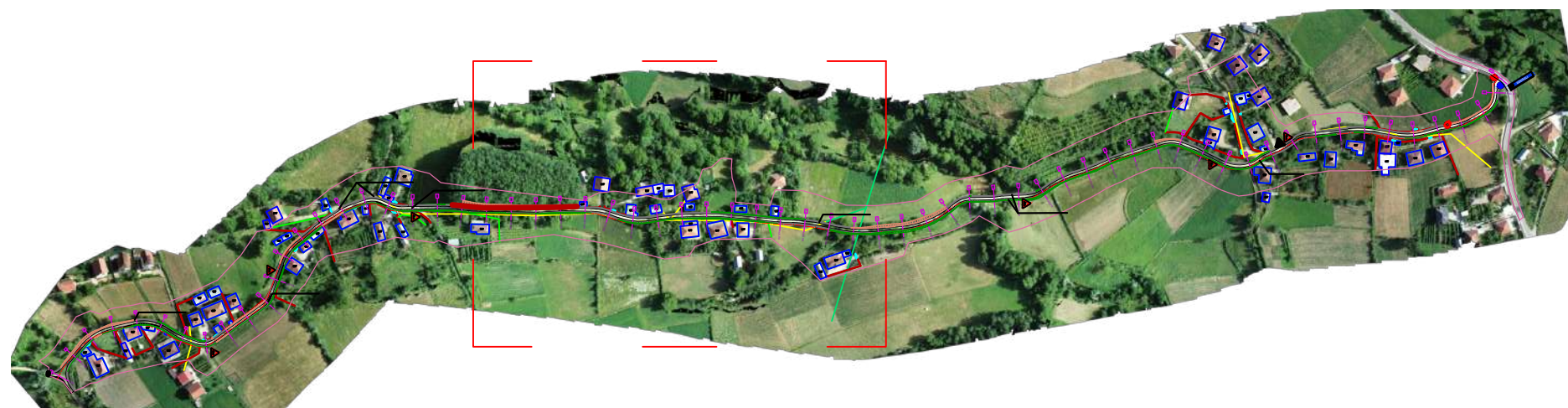

SISTEM-ASFALTIM I
RRUGES LAGJA RUSE -
JELLE, FSHATI HOMESH,
SHUPENZE,
BASHKIA BULQIZE

POROSITESI :



PROJEKTUES :

"HYDRO-ENG CONSULTING"
sh.p.k



"IDEAL CONSTRUCTION
& PROJECTION"(I.C.P) sh.p.k



"P.C.S COMPANY" sh.p.k



GRUPI I PROJEKTIMIT

Ing.Hidroteknik Evis QYRKU	Nr. Licence K.1829/2
Ing. Ndertimi Alban DAUTAJ	Nr. Licence K.2232/2
Ing. Ndertimi Pamela KURTULAJ(ALIU)	Nr. Licence K.1474/3
Arkitekt Endrit TUZI	Nr. Licence A.0128/6
Ing.Topograf Maksim GEGA	Nr. Licence T.0455/4
Ing.Gjeodet Albin KOCI	Nr. Licence E.1269/2
Ing.Elektrik Edmond PALODHI	Nr. Licence E.1552
Ing.Gjeolog Asllan BASHA	Nr. Licence GJ.0686
Ing.Mjedisi Shpetim CIKU	Nr. Licence A.2443
Ing.Hidroteknik Xhuljana DAUTAJ(SULA)	Nr. Licence K.2232/2
Arkitekt Jorida GRABOVARI	Nr. Licence A.2595

FIRMA/VULA

SHENIME

TE DHENA TEKNIKE

FAZA E PROJEKTIT	PROJEKT ZBATIM
TIPI I FLETES	
EMERTIMI I FLETES	PLANIMETRIA 1:1000

Nr. i fletes **A-35**

SINJALISTIKA- RRUGA RUSE JELLE SH 1: 1000

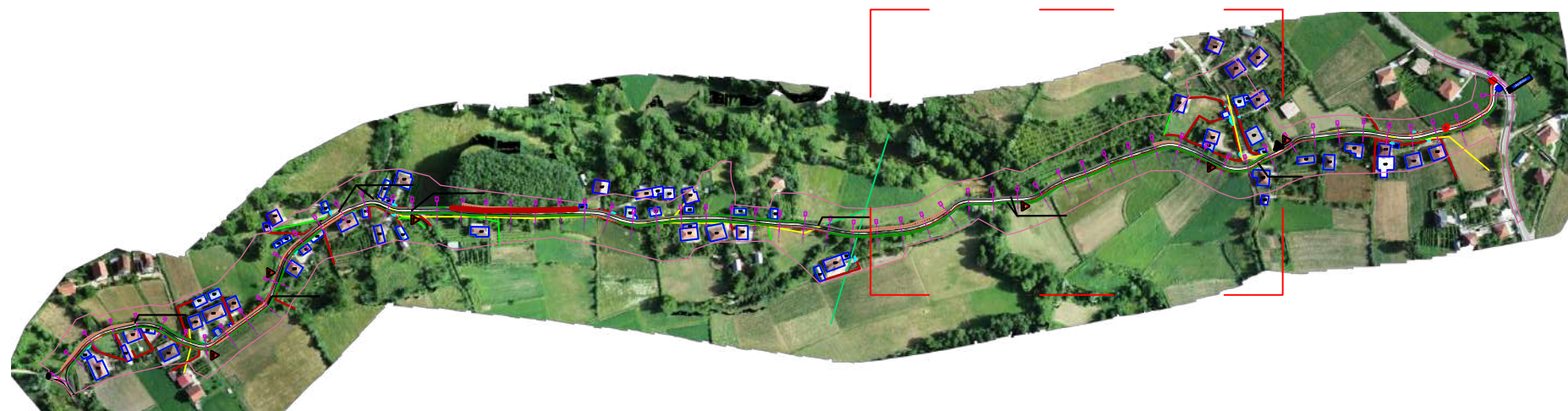

SISTEM-ASFALTIM I
RRUGES LAGJA RUSE -
JELLE, FSHATI HOMESH,
SHUPENZE,
BASHKIA BULQIZE

POROSITESI :



PROJEKTUES :

"HYDRO-ENG CONSULTING "
sh.p.k



"IDEAL CONSTRUCTION
& PROJECTION"(I.C.P) sh.p.k



"P.C.S COMPANY " sh.p.k



GRUPI I PROJEKTIMIT

Ing.Hidroteknik Evis QYRKU	Nr. Licence K.1829/2
Ing. Ndertimi Alban DAUTAJ	Nr. Licence K.2232/2
Ing. Ndertimi Pamela KURTULA,(ALIU)	Nr. Licence K.1474/3
Arkitekt Endrit TUZI	Nr. Licence A.0128/6
Ing.Topograf Maksim GEGA	Nr. Licence T.0455/4
Ing.Gjeodet Albin KOÇI	Nr. Licence E.1269/2
Ing.Elektrik Edmond PALODHI	Nr. Licence E.1552
Ing.Gjeolog Aslan BASHA	Nr. Licence G.J.0686
Ing.Mjedisi Shpetim CIKU	Nr. Licence A.2443
Ing.Hidroteknik Xhujana DAUTAJ,(SULA)	Nr. Licence K.2232/2
Arkitekt Jorida GRABOVARI	Nr. Licence A.2595

FIRMA/VULA

SHENIME

TE DHENA TEKNIKE

FAZA E PROJEKTIT	PROJEKT ZBATIM
TIPI I FLETES	
EMERTIMI I FLETES	PLANIMETRIA 1:1000

Nr. i fletes A-36

SINJALISTIKA- RRUGA RUSE JELLE SH 1: 1000

SISTEM-ASFALTIM I
RRUGES LAGJA RUSE -
JELLE, FSHATI HOMESH,
SHUPENZE,
BASHKIA BULQIZE

POROSITESI :



PROJEKTUES :

"HYDRO-ENG CONSULTING"
sh.p.k



"IDEAL CONSTRUCTION
& PROJECTION"(I.C.P) sh.p.k



"P.C.S COMPANY" sh.p.k



GRUPI I PROJEKTIMIT

Ing.Hidroteknik Evis QYRKU	Nr. Licence K.1829/2
Ing. Ndertimi Alban DAUTAJ	Nr. Licence K.2232/2
Ing. Ndertimi Pamela KURTULAJ(ALIU)	Nr. Licence K.1474/3
Arkitekt Endrit TUZI	Nr. Licence A.0128/6
Ing.Topograf Maksim GEGA	Nr. Licence T.0455/4
Ing.Gjeodet Albin KOCI	Nr. Licence E.1269/2
Ing.Elektrik Edmond PALODHI	Nr. Licence E.1552
Ing.Gjeolog Asllan BASHA	Nr. Licence GJ.0686
Ing.Mjedisi Shpetim CIKU	Nr. Licence A.2443
Ing.Hidroteknik Xhuljana DAUTAJ(SULA)	Nr. Licence K.2232/2
Arkitekt Jorida GRABOVARI	Nr. Licence A.2595

FIRMA/VULA

SHENIME

TE DHENA TEKNIKE

FAZA E PROJEKTIT	PROJEKT ZBATIM
TIPI I FLETES	
EMERTIMI I FLETES	PLANIMETRIA 1:1000

Nr. i fletes **A-37**



PROFILA TERTHOR TIP SH 1:30

**PROFIL TERTHOR TIP 1
(ME BANKINE)
SHK. 1:30**

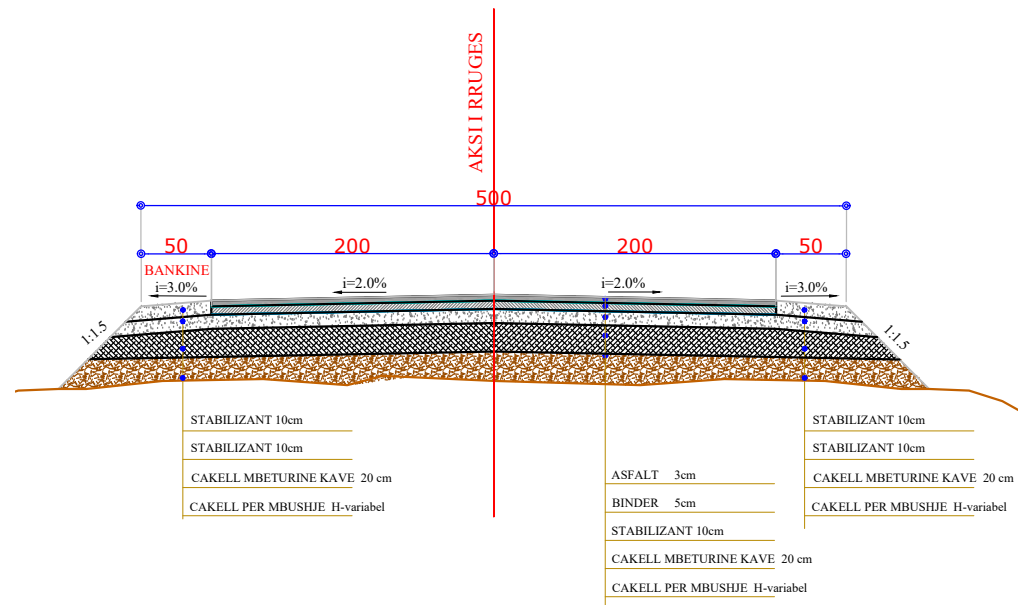

**PROFIL TERTHOR TIP 2
(ME BORDURE DHE KUNETE)
SHK. 1:30**

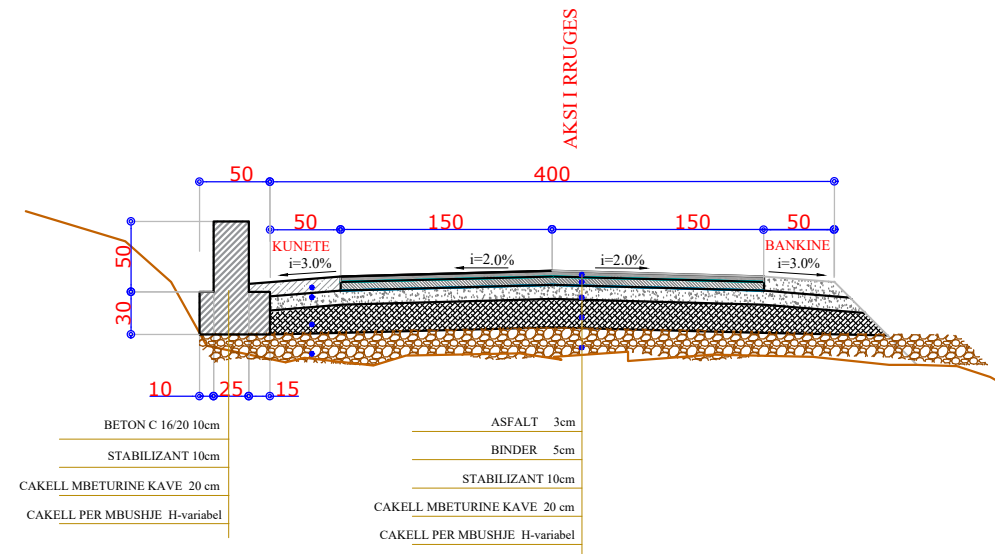

**PROFIL TERTHOR TIP 3
(ME KANAL KULLIMI)
SHK. 1:30**

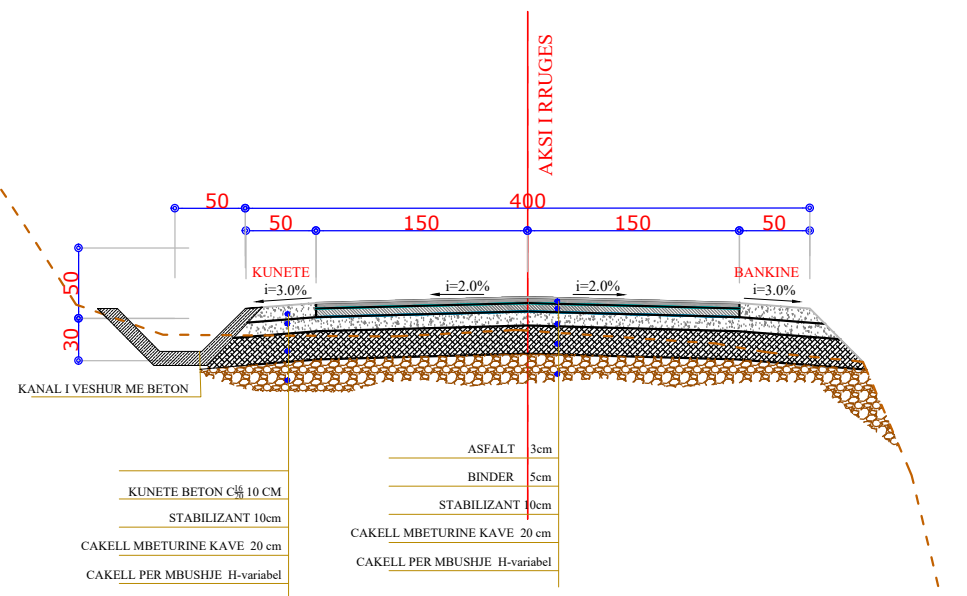

O B J E K T I

SISTEM-ASFALTIM I
RRUGES LAGJA RUSE -
JELLE, FSHATI HOMESH,
SHUPENZE,
BASHKIA BULQIZE

POROSITESI :

BASHKIA BULQIZE



PROJEKTUES :

"HYDRO-ENG CONSULTING"
sh.p.k



"IDEAL CONSTRUCTION
& PROJECTION"(I.C.P) sh.p.k



"P.C.S COMPANY" sh.p.k



GRUPI I PROJEKTIMIT

Ing.Hidroteknik Evis QYRKU	Nr. Licence K.1829/2
Ing. Ndertimi Alban DAUTAJ	Nr. Licence K.2232/2
Ing. Ndertimi Pamela KURTULAJ(ALIU)	Nr. Licence K.1474/3
Arkitekt Endrit TUZI	Nr. Licence A.0128/6
Ing.Topograf Maksim GEGA	Nr. Licence T.0455/4
Ing.Gjeodet Albin KOCI	Nr. Licence E.1269/2
Ing.Elektrik Edmond PALODHI	Nr. Licence E.1552
Ing.Gjeolog Asllan BASHA	Nr. Licence GJ.0686
Ing.Mjedisi Shpetim CIKU	Nr. Licence A.2443
Ing.Hidroteknik Xhujana DAUTAJ(SULA)	Nr. Licence K.2232/2
Arkitekt Jorida GRABOVARI	Nr. Licence A.2595

FIRMA/VULA

SHENIME

TE DHENA TEKNIKE

FAZA E PROJEKTIT	PROJEKT ZBATIM
TIPI I FLETES	
EMERTIMI I FLETES	PROFILA TIP SH 1:30

Nr. i fletes **A-38**

PROFILA TERTHOR TIP SH 1:30

**PROFIL TERTHOR TIP 4
(ME TOMBINO BETONI)
SHK. 1:30**

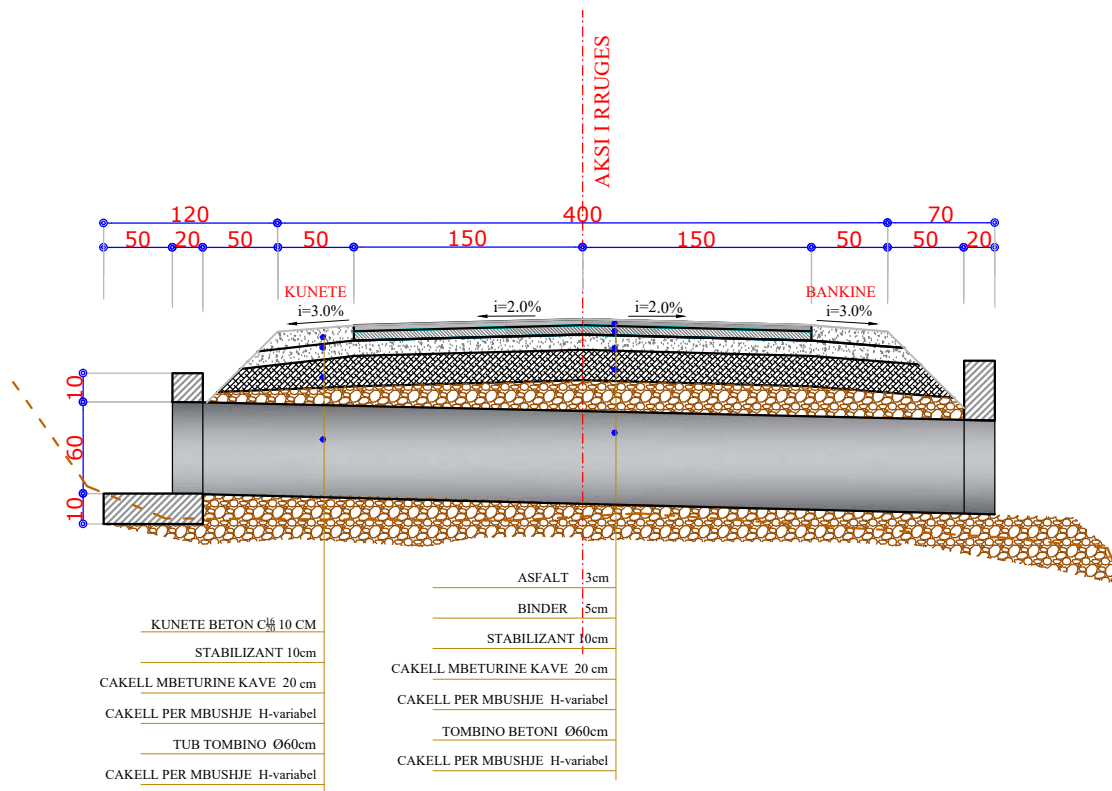

**PROFIL TERTHOR TIP 5
(ME TUB CELIKU DHE KANAL KULLIMI)
SHK. 1:30**

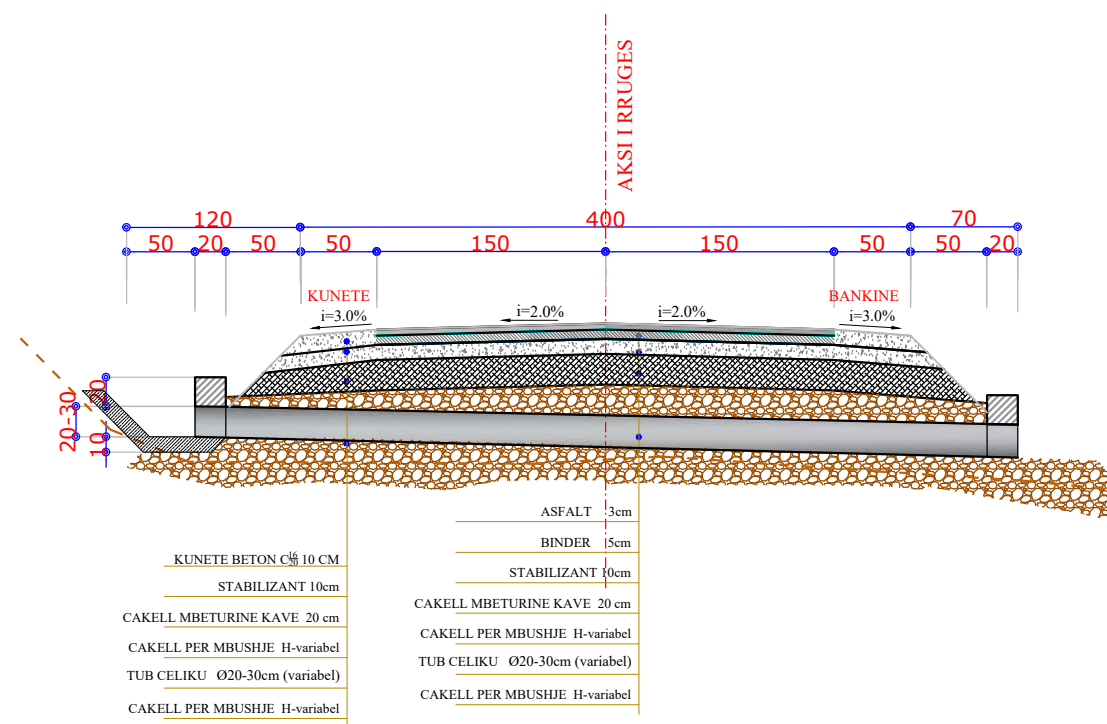

**PRERJE TERTHORE GUARDRAIL
Tip H2W4**

SHK. 1:30

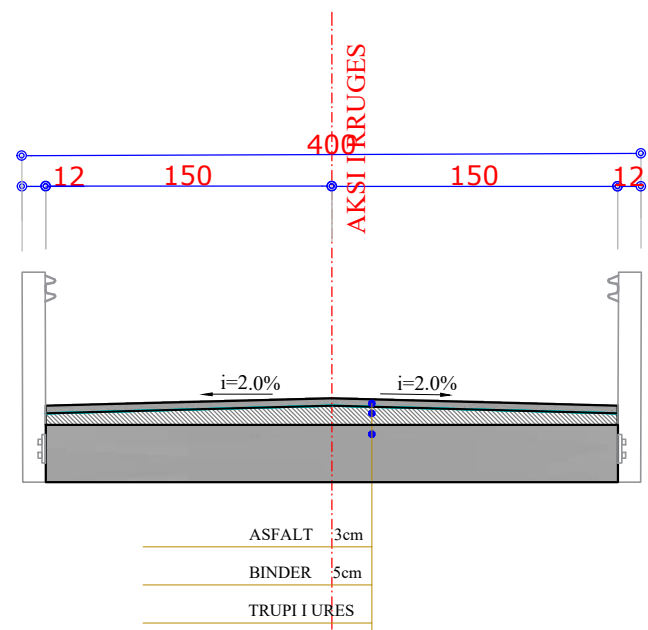

PRERJE TERTHORE HANDRAIL

SHK. 1:30

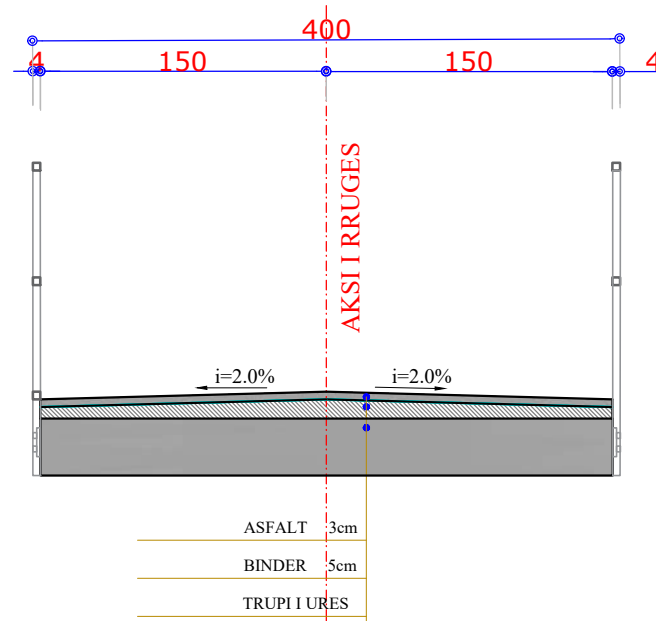

PAMJE GJATESORE GUARDRAIL - HANDRAIL

SHK. 1:30

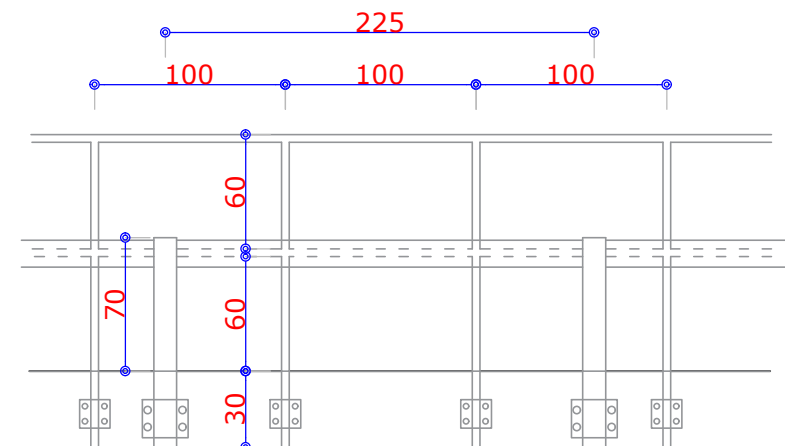

O B J E K T I

SISTEM-ASFALTIM I
RRUGES LAGJA RUSE -
JELLE, FSHATI HOMESH,
SHUPENZE,
BASHKIA BULQIZE

POROSITESI :
BASHKIA BULQIZE



PROJEKTUES :

"HYDRO-ENG CONSULTING"
sh.p.k



"IDEAL CONSTRUCTION
& PROJECTION"(I.C.P) sh.p.k



"P.C.S COMPANY" sh.p.k



GRUPI I PROJEKTIMIT

Ing.Hidroteknik Evis QYRKU	Nr. Licence K.1829/2
Ing. Ndertimi Alban DAUTAJ	Nr. Licence K.2232/2
Ing. Ndertimi Pamela KURTULAJ(ALIU)	Nr. Licence K.1474/3
Arkitekt Endrit TUZI	Nr. Licence A.0128/6
Ing.Topograf Maksim GEGA	Nr. Licence T.0455/4
Ing.Gjeodet Albin KOCI	Nr. Licence E.1269/2
Ing.Elektrik Edmond PALODHI	Nr. Licence E.1552
Ing.Gjeolog Asllan BASHA	Nr. Licence GJ.0686
Ing.Mjedisi Shpetim CIKU	Nr. Licence A.2443
Ing.Hidroteknik Xhuljana DAUTAJ(SULA)	Nr. Licence K.2232/2
Arkitekt Jorida GRABOVARI	Nr. Licence A.2595

FIRMA/VULA

SHENIME

TE DHENA TEKNIKE

FAZA E PROJEKTIT PROJEKT ZBATIM

TIPI I FLETES

EMERTIMI I FLETES PROFILA TIP
SH 1:30

Nr. i fletes A-39

DETAJE - SINJALISTIKE

O B J E K T I

SISTEM-ASFALTIM I
RRUGES LAGJA
RUSE-JELLE, FSHATI
HOMESH, SHUPENZE,
BASHKIA BULQIZE

POROSITSI :
BASHKIA BULQIZE



PROJEKTUES :

"HYDRO-ENG CONSULTING"
sh.p.k



"IDEAL CONSTRUCTION
& PROJECTION"(I.C.P) sh.p.k



"P.C.S COMPANY" sh.p.k



GRUPI I PROJEKTIMIT

Ing.Hidroteknik Evis QYRKU	Nr. Licence K.1829/2
Ing. Ndertimi Alban DAUTAJ	Nr. Licence K.2232/2
Ing. Ndertimi Pamela KURTULAJ(ALIU)	Nr. Licence K.1474/3
Arkitekt Endrit TUZI	Nr. Licence A.0128/6
Ing.Topograf Maksim GEGA	Nr. Licence T.0455/4
Ing.Gjeodet Albin KOCI	Nr. Licence E.1269/2
Ing.Elektrik Edmond PALODHI	Nr. Licence E.1552
Ing.Gjeolog Asllan BASHA	Nr. Licence GJ.0686
Ing.Mjedisi Shpetim CIKU	Nr. Licence A.2443
Ing.Hidroteknik Xhuljana DAUTAJ(SULA)	Nr. Licence K.2232/2
Arkitekt Jorida GRABOVARI	Nr. Licence A.2595

FIRMA/VULA

SHENIME

TE DHENA TEKNIKE

FAZA E PROJEKTIT	PROJEKT ZBATIM
TIPI I FLETES	
EMERTIMI I FLETES	Detaj

Nr. i fletes **A-40**

SHENJA LAJMERUESE

LAJMERIM PER NDERPRERJE NGA RRUGE DYTESORE, KTHESAT E KURBEZUARA,
FEMIJET, KEMBESORET DHE PER NDALJE/DHENIE RRUGE

TREKENDESHI: E KUQE REFLEKTUESE
SFONDI: I ZI
SYMBOLI: E BARDHE REFLEKTUESE

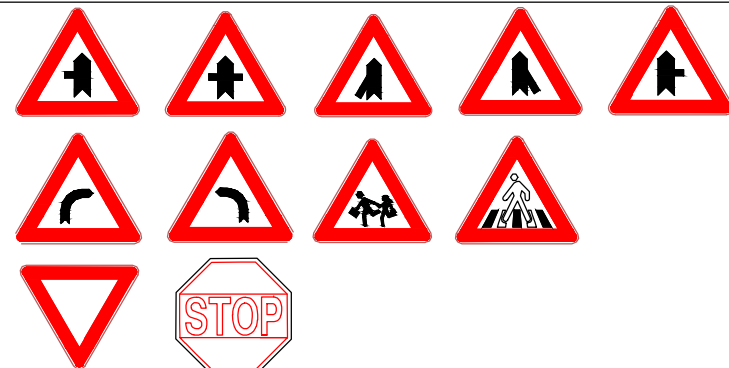

PERMASAT E SHENJAVE STANDARTE

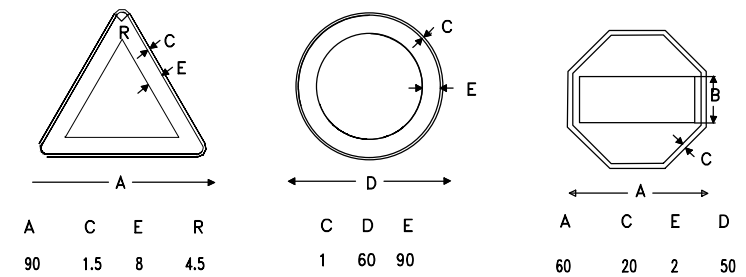

SHENJA NDALUESE

SHENJAT PER KUFIRIN E SHPEJTESISE DHE NDALIM PARAKALIMIN

RRETHI: E KUQE REFLEKTUESE
SHENJA: E ZEZE REFLEKTUESE

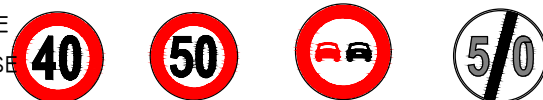

SHENJA INFORMUESE

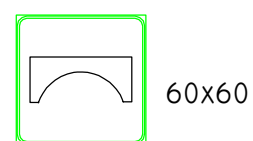

URE

Shenim: Shenjat rrugore per nga forma, madhesia, ngjyra reflektiviteti duhet te jene sipas Kodit Rrugor te Republikes se Shqiperise Materiali praparefektiv duhet te kete jetegjatesi 10vjet per Clasin 2 dhe 7 vjet per Clasin 1 Simboli brenda shenjes rrugore duhet te jete i realizuar me boje te trajtuar me pjekje e cila nuk humbet treguesit praparefektiv Shenja rrugore realizohet me llamarine çeliku e cila lyhet me boje opake kundrandra korozionit dhe trajtohet me pjekje.

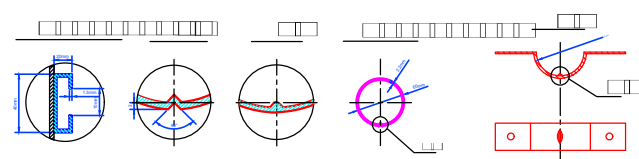
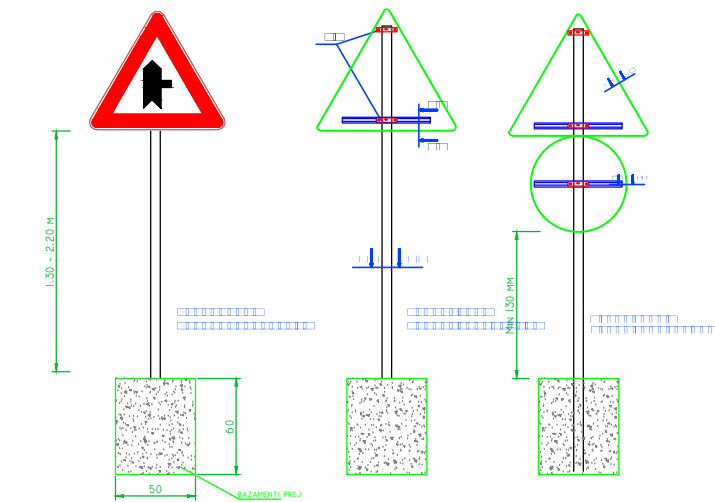

TIPET E VIZIMEVE TE RRUGES

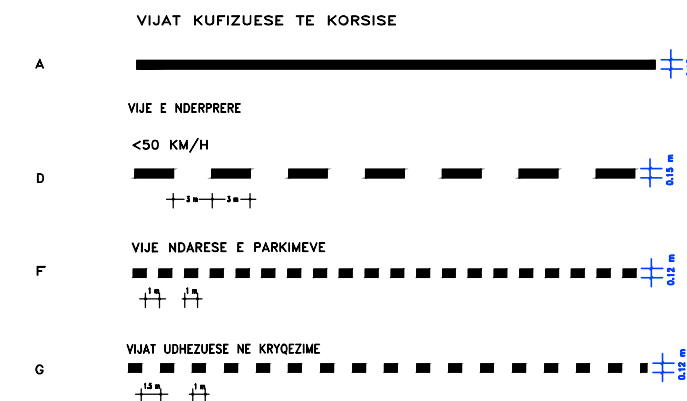

Vizimi i rruges

